



Australian Government
Civil Aviation Safety Authority

Flight Instructor Manual A E R O P L A N E

ISSUE 2 : D E C E M B E R 2 0 0 6



I have long held the view that one of the important ingredients for a safe and viable aviation industry is a properly resourced flying training sector.

Some of those resources can be quite basic. For example, an important contribution to training is for flying instructors to have available to them a basic guide to elementary flying training.

Publication 45, the Flight Instructor's Manual first published by the Department of Civil Aviation in 1967, has served the flying training sector well over the years. Over time, however, the language and style have become outdated, and there was a need for the contents to be 'refreshed'.

I asked a small team to take a look at Publication 45, update it where needed, and put it into a form that could go out to the industry for comment. This resulted in Flight Instructors Manual (FIM) (Issue 1), which was provided to every current fixed wing flying instructor in Australia.

Following extensive industry consultation, including a CASA funded workshop for senior industry instructors, Issue 2 of the FIM was developed. I now proudly release this version, which I plan to have reviewed periodically

Bruce Byron AM

Chief Executive Officer
November 2006



CONTENTS

Chapter	Page
	i Foreword
	2 Introduction
	4 The flying instructor
	6 Students
01 Familiarisation with the aeroplane and air experience	7
02 Preparation for flight	8
03 Taxiing	9
04 Operation of controls	11
05 Straight and level flight	16
06 Climbing	19
07 Descending	22
08 Turning	25
09 Stalling	32
10 Sideslipping	36
11 Take-off	38
12 Approach and landing	43
13 Spins and spirals	52
14 First solo	57
15 Emergency and special procedures	58
16 Pilot navigation	64
17 Instrument flying night	72
18 Night flying	86



INTRODUCTION

The history of this Flight Instructors Manual (Issue 2), published by CASA in 2006 has very interesting origins.

Robert Smith-Barry (1886 – 1949) was one of the first pilots to train at Central Flying School (CFS) and in the early stages of World War (WW) 1 (1914 – 1918) casualty rates at flying training establishments exceeded the number lost in combat. Smith-Barry secured approval to return to Britain and re-organize training at CFS in August 1917.

Smith-Barry's training doctrine clearly stressed that students were not to be led away from potentially dangerous manoeuvres but were instead to be exposed to them in a controlled environment in order that the student could learn to recover from instinctive errors of judgement.

Smith-Barry's methods were so successful as to gain worldwide renown and his approach to flying training was rapidly adopted by many allied air forces. He also served in a flying training role in WW2 (1939 – 1945).

The influence of Smith-Barry's flying training philosophies was most evident in the Empire Air Training Scheme of WW2, which trained some 37500 Australians as well as New Zealanders, Canadians and Rhodesians. In fact the 'flying training bible' of that era as adapted (AP1732A) was used almost exclusively in civil aviation flying training in Australia for about 20 years after WW2. That publication was the basis for the Australian flight instructor's manual - Publication 45, which served the civil flying training industry from 1967 until 2005.

This Flight Instructors Manual has its foundations in the documents mentioned above.

This manual has been written with the aim of presenting flying instructors of all experience levels a guide to elementary flying training. As flying instructional technique must to a large extent depend on the characteristics of the particular type of aeroplane and equipment being used, no direct reference is made to any particular type of aeroplane or equipment. It is sufficiently comprehensive to cover all aspects of flying training on simple aeroplanes with fixed undercarriages and fixed pitch propellers.

The manual will be of greatest benefit to the instructor if he or she understands how to use it correctly. Some



explanation of the arrangement and use of this manual is therefore given in the following paragraphs.

Although the exercises have been arranged in a logical order, this does not imply an order of importance or chronological order in which the exercises should be taught. The scope of each exercise, with the possible exception of Exercises 1 to 3, is such that it is unlikely that most students will become completely competent in each prior to first solo. It is an acceptable principle that in the early stages of training, instruction should be restricted to simple manoeuvres and no attempt made to teach really precise flying until the student has completed some solo flying and gained confidence.

Instructors must be familiar with the CASA Day VFR Syllabus (or the equivalent document in the future) which, amongst other matters, sets out the standards that must be achieved during various phases of training. Consideration was given to reproducing parts of that document in this manual. However, the idea was rejected on the grounds that flying instructors will have access to the Day VFR Syllabus in their flying training organisation.

The exercises are divided so far as is practicable into four parts:

- (i) Aim
- (ii) Instructional Guide
- (iii) Pre-Flight Briefing Considerations
- (iv) Air Exercise

The Aim as stated at the commencement of each exercise gives an overall picture of just what the instructor is ultimately endeavouring to teach the student.

The Instructional Guide contains advice to instructors and should be helpful in teaching the particular exercise.

The Pre-Flight Briefing Considerations are a brief explanation of the principles underlying the exercise.

It is imperative that the student receives an adequate briefing prior to attempting to learn a lesson in the air. There is no real substitute for a thorough briefing by the instructor on the exercise about to be taught. The instructor should use the considerations outlined in this manual to develop a picture of the exercises as a whole, but the manual is not the place for involved explanations on principles of flight, engine handling and the like. For this reason numerous detailed diagrams, formulae and complex explanations have, as far as possible, been avoided. The instructor should use the appropriate textbooks as the source of detailed information.

The pre-flight briefing is aimed at confirming recency to theory taught in theory lessons or self study.

Under normal circumstances the pre-flight briefing should be no longer than 15 minutes. Questioning should demonstrate the student's preparation. Additionally, a brief description of how the sequence will be managed and the instructor's expectation of the student should be clearly articulated.

The Air Exercises are a series of planned lessons arranged to provide the instructor with specific and clear direction on what to teach and how to teach it. Because of the various types of aeroplanes used, no set pattern is provided. Further, parrot-like repetition of words is undesirable, and for these reasons no set pattern is given. Rather, the instructor should put into his or her own words the instruction to be given in the air. Each instructor will, in any case, develop a personal style in talking to the student in the air as experienced is gained.

Generally the instructor should first demonstrate all air exercises and then the student should try them. Some exercises, for example spinning, are best taught by first demonstrating, then having the student manipulate the controls together with the instructor and then trying it with the instructor monitoring.

Flights should be linked in a logical sequence, often described as the building block approach. Ideally a demonstration should be given at the end of each flight showing what will be covered in the next flight.



THE FLYING INSTRUCTOR

An instructor must be a good pilot and although his/her flying must be smooth and polished it must also be spirited. The instructor must possess and outwardly demonstrate a high standard of discipline, common sense and initiative, which are the cornerstones of airmanship.

The instructor must also display leadership qualities, without which the above qualities will be lacking.

There are times when an instructor may give an explanation that is lacking in detail for the purpose of not confusing or overloading the student, especially in the early stages of training.

The good instructor generally knows if there is a personal problem bothering the student and may show welcomed concern to the student by casually asking how the matter is unfolding. This style creates an atmosphere of apparent care in the mind of the student and can improve his/her overall performance on the day.

Evidence suggests that as instructors deal with students who are frequently under stress the instructor gets to know the student, in some aspects of life, to a greater degree than a family member or even a spouse. Because of these circumstances an instructor may become more to the student than simply a specialist teacher. Instances of students seeking advice from their flying instructor on various matters outside of aviation, including life style issues, are not uncommon. Should a student become intrusive in the life of an instructor the matter needs to be dealt with very firmly and at an early stage.

The airborne working conditions of an instructor are often cramped with poor seating as well as being either too warm or too cold. These factors can be compounded by turbulence and having to monitor an often-busy radio frequency coupled with poor student performance during repetitive exercises. Nevertheless, instructors must develop or enhance patience and perseverance with both attributes being sorely tested by some students and the working conditions but weaknesses in these areas should never be obvious to the student.

Instructors need to avoid unnecessary chatter in the air, which is a frequent weakness with many instructors who mean well but effectively 'swamp' their student's with information. In the early stages of training a student should normally only be corrected immediately for lapses

in airmanship. Allowing the student to experiment, especially with fault corrections, will usually pay dividends in the long run. In the case of an excessive delay in fault correction keywords like 'balance', 'height' or 'trim' said in a firm but friendly tone may produce better results than a lengthy dissertation. Sometimes it may be prudent for the instructor not to even comment on an error in the early stages of training unless the student is frequently demonstrating a similar error.

'Standard patter' is attractive from a lesson preparation perspective but does have disadvantages because of different learning rates.

The delivery rate of new information has to be judged carefully as even one 'package' (i.e. part of a lesson) that is overly complicated in the mind of the student may downgrade the student's performance for the remainder of the lesson. The acceptable delivery rate of new information to the student needs to be combined with good demonstrations and adequate student practice.

The latter is often rushed and this failure to allow for consolidation will ultimately lead to longer term slowing of the student's progress, especially during the early lessons on circuits.

An instructor should assume full control of the aircraft when it is necessary to re-brief or debrief the student in flight. This allows the student to better concentrate on what is being said.

Airborne sequences must follow an acceptable method of teaching like: Demonstrate, Direct then Monitor. Remember that at times two or more demonstrations may be required, each perhaps with a slightly different emphasis, in order to correct consistent faults.

Junior instructors often fall into the trap of constantly assessing their students rather than simply correcting their errors and patiently guiding them through new sequences. The teaching and testing roles in flying training are different issues and the latter is reserved for more experienced instructors who are approved testing officers.

If remedial instruction is required for a correctly identified problem it often only involves a re-demonstration or an alternative approach to the particular problem.



Instructors need to be diligent in identifying the real cause of a poor performance. Sometimes the cause may result from prior poor performance i.e. a poor landing will frequently follow a poor approach.

Despite the above, when a student is not progressing at the expected rate a careful examination of all relevant factors needs to be undertaken. This may involve self-examination by the instructor concerned or an instructor change may be warranted at the discretion of a senior instructor or the chief flying instructor.

Instructors involved in training or testing other flying instructors need to develop role playing skills of acting as a student pilot. Just as handover and takeover drills are used to prevent confusion on who is manipulating the controls a similar drill needs to be used for the commencement and termination of this role playing. The expressions "Bloggs on" and "Bloggs off" are widely used for these purposes.

Note: 'Bloggs' is a term of endearment used generically to describe a pilot under training

Instructors must let the student make the radio calls. There can be a tendency for instructors to over use the radio.



STUDENTS

A common misconception amongst the flying instructor fraternity is the relative ease of teaching students who have been through a rigorous screening and selection process when compared to students who have merely demonstrated the financial means to buy flying lessons.

The former category of students will be within a fairly restricted young age bracket, meet the highest medical standards, have a minimum education standard and passed all other selection criteria. However, on average half of these candidates will fail to graduate if they are part of a military system. Such a high failure rate puts obvious pressure on the students but also places extremely high demands on their flying instructors.

Much has been written about 'types' of student pilots over the years, generally categorizing them into broad groups such as:

- Over confident
- Under confident
- Forgetful
- Lazy
- Uncoordinated

However, in real life each student is very much unique, with every student providing special challenges to ensure they graduate.

There is no test or series of tests that a potential student pilot can undertake which will guarantee success in flying training. Such tests are more likely to indicate that a student may have problems with certain aspects of the training course. However, whilst the golden rules of purchasing real estate is said to boil down to three specific factors, namely **location, location and location** a similar rule applies to student pilots. Amongst all the attributes that a student pilot must possess the three greatest are in rank order **enthusiasm, enthusiasm and enthusiasm**.

There is a significant number of students that learn to fly who have no genuine desire to do so. Consequently, these students can be difficult to teach because they may have an associated lack of motivation.

Should a student suddenly or even progressively show signs of deteriorating performance over one or two flights (or more) the instructor needs to use non intrusive questioning to see what is troubling the student. If the problem stems from antipathy between the student and instructor it may be prudent for the student to fly with a different instructor.

Instructors need to remember that what appears to be an inane question from a student, especially in the early stages of training, needs to be answered if at all possible in order to reduce the student's stress level.



01 FAMILIARISATION WITH THE AEROPLANE AND AIR EXPERIENCE

AIM

To familiarize the student with the aeroplane's controls and systems. To introduce the student to drills, check lists, and the sensations of flight.

INSTRUCTIONAL GUIDE

This exercise will not involve a great deal of instruction but if well carried out, can have a good and lasting influence on the student's future attitude towards learning to fly. It should culminate in giving the student who has not flown in a light aeroplane, a brief flight to familiarize him or her with this new sensation.

Take the student to the aeroplane and point out the external features first. At this stage point out only the main features such as the control surfaces, refuelling points, undercarriage and propeller.

The student can then be seated in the pilot's seat and the cockpit layout briefly explained. This should be done in a logical sequence. Where checklists and drills are normally used, these should be employed to emphasize right from the beginning the importance of systematic checking.

Remember all through this exercise that it is important not to expect too much from the student. Answer any questions the student may have in as simple a way as possible and do not let the student get too involved with technicalities at this stage. In some circumstances the instructor may also need to be a sales person if the student does not appear to be enthusiastic or is overly nervous.

AIR EXPERIENCE

If possible the flight should be made in good weather, as many potential pilots have been frightened away by a rough and unpleasant first flight. Very little instruction should be given at this stage though if the student appears to be comfortable the student should be allowed to 'follow the instructor through' on the controls and even manipulate them for a short while.

The instructor should point out obvious landmarks and the horizon. The readings of the airspeed indicator and altimeter can be brought to the student's attention. If the student requests the instructor to do some manoeuvre other than normal flight and the instructor feels that the student will not suffer, then do this manoeuvre though it is advisable to do it as gently and smoothly as possible for the first time, even with the most exuberant student. If there is some good reason why this cannot be done, do not refuse to do it without explaining why, or the student will draw his own conclusions.

At some stage during the flight it may be beneficial to explain to the student that only a 'gentle touch' is required to control the aeroplane.

After landing, explain briefly to the student what the next exercise is to be. Indicate to the student what should be read and learned before the next exercise as this will save time before the next flight.



02 PREPARATION FOR FLIGHT

AIM

To teach the student how to ensure that the aeroplane is prepared and airworthy for flight plus the actions to be taken after a flight.

INSTRUCTIONAL GUIDE

Before walking out to the aeroplane the instructor should show the student the documents that indicate the serviceability state of the aeroplane. The instructor should explain how the fuel and oil state can be determined, whether any work has recently been carried out on the aeroplane and why the pilot must review and possibly sign certain documents before flying the aeroplane.

The instructor should now teach the student the pre-flight checks in much greater detail than was done in Exercise 1. The instructor should point out that:

- (i) the position of the aeroplane for starting and running up should be such that no inconvenience or damage is caused by the slipstream and that no loose stones, etc., will be picked up by the propeller and damage it. It is also important that some types of aeroplane be headed into wind to reduce fire risk on starting; and
- (ii) the path for taxiing should be clear and that any obstructions are noted so that they can be avoided.

The instructor should ensure that the student is able to reach all controls, while at the same time is comfortable and high enough in the seat for good outside visibility and attitude judgment. It is important for the student to be always seated with their eyes on the same level so that the aeroplane's attitude for each manoeuvre remains substantially constant. The preliminary internal checks should then be done with the student taking an active part in carrying out these checks.

When starting and warming up the engine the instructor must ensure that the student is aware of the responsibilities with respect to persons outside the aeroplane. The student should be made to ensure that all is clear by visual inspection and by getting into the routine of shouting 'clear propeller' before actuating the starter.

The instructor must make the student very conscious of engine instrument indications.

When carrying out the run up checks the instructor must ensure that the student observes the engine temperature and pressure limitations. If the aeroplane has been moved before the run up check is done, the instructor must ensure that the student does not attempt to run up the engine if there is loose gravel in the immediate vicinity. Make the student aware once again of the damage to the propeller that this practice can cause. Explain why run ups should be conducted into wind and the need to ensure the propeller wash is not causing harm or annoyance.

The correct method of stopping an engine must also be taught. It should be explained to the student that the correct method will prevent damage caused by uneven cooling of the engine and damage to the exhaust system. Impress upon the student the necessity to ensure that the ignition and master switch is off and that the aircraft is correctly secured before leaving the aeroplane.

During the above walk around, it is also prudent to ensure that there is no obvious damage or oil leaks. Post flight documentation requirements should follow immediately.

In all these procedures allow the student to do as much as possible. Allow the student to start the engine and to manipulate the engine controls during the power check. Doing even these relatively minor tasks will give the average student a great sense of achievement.

Obviously all the points raised in this exercise cannot be taught in one lesson but will be spread over several. The student should be familiar with all drills, vital actions and pre take-off safety brief before his or her first solo flight. Insist from the beginning that the student repeats aloud these checks so that you can monitor them, and never allow the student to become so automatic (ritualistic) that they repeat the check aloud but do not physically carry it out. This is often a fault with students and shows a basic lack of understanding of the reasons for these checks.



03 TAXIING

AIM

To teach the student to manoeuvre the aeroplane safely on the ground.

INSTRUCTIONAL GUIDE

Instruction in taxiing must be commenced as soon as possible and the pupil should be allowed to do all the taxiing at an early stage, the instructor taking control only when necessary.

From the beginning, impress upon the student the need to taxi at a reasonable speed considering safe and expeditious movement of traffic and to keep a sharp lookout for other aircraft and obstacles.

In confined areas a pilot may request or be offered taxi guidance. However, the ultimate responsibility for the safety of the aeroplane still rests with the pilot.

PRE-FLIGHT BRIEFING CONSIDERATIONS

- **Aeroplane Inertia** Explain fully the effect of inertia on starting and stopping, stressing the use of power to start the aeroplane moving and the need to anticipate the inertia effect when stopping and turning
- **C of G position** Explain the effect of having the C of G forward or aft of the main wheels as applicable to the type of aeroplane.
- **Directional Control** Explain the use of the rudder, nose wheel steering and the brakes in controlling direction on the ground
- **Brakes** In addition to explaining the use of brakes to assist in controlling direction, explain how to test the brakes as soon as the aeroplane is moving. Stress that harsh braking should be avoided, except in an emergency
- **Use of Power** Explain how taxiing speed is controlled primarily by power. Emphasis engine pressure and temperature limitations and the need to avoid prolonged idling. Stress that power should not be used against the brakes, and when stopping or

slowing down, close the throttle first then apply brakes

- **Effect of Wind** Explain the effect of wind on the aeroplane whilst taxiing into wind, down wind and cross wind. Explain the position of the flying controls whilst taxiing in various wind conditions as applicable to the type of aeroplane
- **Cold Weather** Operations Explain that carburettor icing is possible and how to remedy the situation

RULES OF TAXIING

Explain the rules of surface movement to, from and whilst taxiing on the landing area as applicable to the particular aerodrome.

AIRMANSHIP

Stress the need to taxi at a reasonable speed considering the safe and expeditious movement of traffic. Never taxi too fast.

If radio failure is suspected and a control tower is in operation, teach the student to look for signals from the tower.

GROUND EXERCISE

- (a) Use of power
- (b) Control of direction
- (c) Use of brakes
- (d) Effect of wind and use of flying controls
- (e) Instrument checks

USE OF POWER

Demonstrate that the speed of the aeroplane is governed primarily by the use of power. Show that the amount of power needed depends on the ground surface. Make sure that the student is aware that higher power is often necessary to overcome the inertia of a stationary aeroplane and demonstrate that power must be reduced as soon as the aeroplane is moving at the required speed. Emphasize the points to check with respect to engine temperature and pressure limitations and try to avoid long periods with the engine idling too slowly. Always insist that the student operates the throttle smoothly.



CONTROL OF DIRECTION

Show the student how to control direction primarily with the rudder. Make sure that the student understands how to use the nose wheel steering if applicable and demonstrate the use of brakes in controlling direction if this is applicable to the type of aeroplane. Show how to ensure that the path ahead is clear if the design is such that the nose of the aeroplane obscures the view of the taxi path. This is done by turning the aeroplane slightly to the left and looking out of the right hand side and then turning slightly to the right and looking out of the left hand side. Teach the student to anticipate the recovery from a turn and to apply corrective action before the nose of the aeroplane is pointing in the required direction.

USE OF BRAKES

Teach the student to always test the brakes when moving away from the parking position. Do not allow the student to brake harshly unless this is unavoidable and teach never to rely completely on brakes, especially in wet weather. When wishing to stop, close the throttle before applying brakes, avoiding the use of power in opposition to brakes.

EFFECT OF WIND AND USE OF FLYING CONTROLS

Demonstrate how the aeroplane tends to turn into wind (weathercock) when taxiing across the wind. Show that taxiing into the wind is a comparatively simple exercise as the aeroplane tends to keep straight. Show how the aeroplane gains speed as it taxis down wind.

Show how to position the flying controls with significant wind coming from various directions relative to the aeroplane's heading. Some manufacturers give very specific instructions on the use of ailerons and elevators whilst taxiing. When giving instruction in these types the instructor must be thoroughly familiar with the recommended method and teach the student accordingly.

INSTRUMENT CHECKS

As the pupil becomes more proficient at taxiing explain the importance of checking the engine temperature and pressure indications. Additionally, demonstrate how to check the gyro instruments and magnetic compass while taxiing. Include navaid checks if appropriate.

COMMON FAULTS

The most common fault is that a student will tend to taxi too fast, especially as more confidence is gained. Many students become careless about lookout and clearing the blind spot created by the nose of the aeroplane and positioning the flight controls correctly. These faults must be eliminated at an early stage.



04 OPERATION OF CONTROLS

AIM

To teach the student the effect on the aeroplane of movement of the flying controls and the correct method of handling the aeroplane's ancillary controls.

INSTRUCTIONAL GUIDE

The instructor must ensure that the student clearly understands the principles of this exercise. Whilst the fundamentals can be covered in one lesson it is usually necessary to devote further time to cover the full scope of the exercise.

During the flight spare no effort to get the student off to a good start. See that the student is comfortable. Students must have the same seating position for subsequent flights so that the sight picture is not altered. Make sure that the controls are held correctly and that full travel of the controls is possible. Make sure that the student knows what you mean when you refer to the horizon and aeroplane attitude. Other words such as 'elevator', 'rudder', 'flap' and 'trim' may cause confusion for some students as they have a different understanding of the words from non-aeronautical use.

Demonstrate each segment and then allow, whenever appropriate, the student to repeat the particular segment. This should apply to all your instruction. When handing over to students ensure that they are aware of the correct way of handing over and taking over control. Use the term 'handing over' or 'taking over' as applicable. Do not hesitate to hand over one control only e.g. 'Handing over elevator control only' or 'Handing over aileron control only.'

Often it is helpful to have the student 'follow through' (hands and feet lightly on the controls but not making any input) in order that the student gets a feel for what is occurring. This technique may be appropriate for take-offs and landings before formal instruction has been given in the sequence.

When appropriate allow the student to fly the aircraft even if a particular sequence has not been formally taught e.g. climbing out to the training area or descending back to the circuit.

Always keep a good lookout for other traffic, making it obvious to the student that you are doing so, because students tend to model their instructors.

PRE-FLIGHT BRIEFING CONSIDERATIONS

PLANES OF MOVEMENT

Pitching-rolling-yawing. Relate these to the three axes (See Note 1). Emphasize how movement in these planes should be considered relative to the aeroplane itself and not the horizon.

Note 1: If the student is 'straight off the street' (i.e. recent post air experience flight only), an explanation of the three axes and movement about them may confuse the student. Figure 4-1 is helpful when explaining the primary and secondary effects of controls.

CONTROL SURFACES

Elevator-aileron-rudder. Explain the movement of these controls and how they are operated by the pilot.



Figure 4-1: Use of controls—primary and secondary effects

Control	Primary effect	Secondary effect
---------	----------------	------------------

Elevator	Pitch	Nil
----------	-------	-----

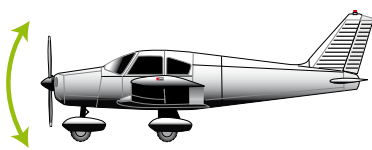

Aileron	Roll	Yaw
---------	------	-----



Rudder	Yaw	Roll
--------	-----	------

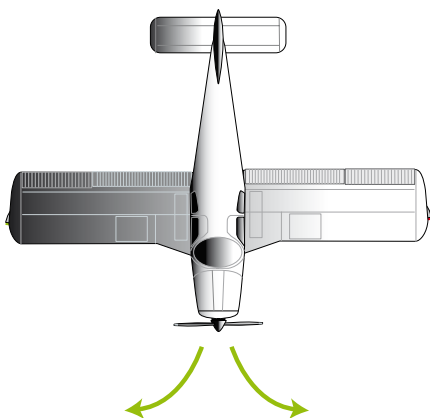

PRIMARY EFFECT OF FLYING CONTROLS

Explain the primary effects of individual movement of elevator, ailerons and rudder.

SECONDARY EFFECTS OF CONTROLS

Explain how an aeroplane which is banked will yaw and conversely how a yaw will cause an aeroplane to bank. Fully explain the attitudes which will result from continued application of ailerons and rudder separately.

EFFECT OF SPEED

Explain the effect of speed and ensure that the student is aware that the effectiveness of all three primary controls is affected by airspeed.

EFFECT OF SLIPSTREAM

Explain that the elevator and rudder only are affected.

TRIMMING CONTROLS

Explain the operation of the trimming devices fitted to the particular aeroplane and their correct method of use. Emphasize that attitude must be kept constant with the primary control whilst trimming the aeroplane.

ANCILLARY CONTROLS

Explain the use of the controls as applicable to the particular type of aeroplane. These controls may include throttle, mixture, carburettor heat, fuel system, engine cooling and flaps.

AIRMANSHIP

Emphasize:

- the need for a good lookout and how to report other traffic
- Hand over take over drills and follow through drills
- Orientation and area boundaries
- Actions in the event of impending air sickness



AIR EXERCISE

- (a) Primary effects of flying controls
- (b) Secondary effects of flying controls
- (c) Effect of airspeed
- (d) Effect of slipstream
- (e) Effect of trim
- (f) Engine controls
- (g) Effect of flaps

For this lesson to be effective there needs to be an easily definable horizon and little, if any, turbulence.

PRIMARY EFFECTS OF FLYING CONTROLS

With the aeroplane trimmed to fly straight and level in a normal cruising configuration demonstrate as follows:

Elevator Show the effect of fore and aft movement of the control column. This is best done by raising the nose and explaining (for a given head position) you see more sky and less ground. Hold the new attitude for several seconds and return the nose attitude to the original position.

This should be followed by student practice having control of the elevator only. The exercise is repeated in the nose low case i.e. the student can see more ground and less sky. Allow the student to control the aeroplane in the pitching plane for sufficient time to learn the feel of the control so that the student can without undue difficulty, place the nose of the aeroplane in a nominated attitude and change from one attitude to another.

Ailerons In straight and level flight draw the student's attention to the position of the wing tips in relation to the horizon.

Ensure the student's feet are not on the rudder pedals during the demonstrations and practices. The instructor prevents secondary effects (yaw).

Lower a wing slightly and explain the new sight picture prior to leveling the wing followed by student practice. Demonstrating lowering and raising the other wing prior to student practice is at the discretion of the instructor, based on the student's earlier performance. The same guidelines apply to how many practices you allow the student to have.

Rudder Ensure the student's hand is not on the control column during the demonstrations and practices. The instructor prevents secondary effects (roll).

Point out the position of the nose or reference point of the aeroplane in relation to a point on the horizon. Apply rudder in one direction and point out that the nose of the aeroplane yaws away from the reference point. Then release the rudder pressure, pointing out that the aeroplane will stop yawing. The same guidelines as shown above apply to a demonstration in the opposite direction and the amount of student practice.

Student practice with all three controls Commencing from straight and level flight the student should then be given the opportunity to gently practice using all three controls with the instructor performing only a monitoring role.

Reacting of control input relative to aeroplane

Demonstrate the primary effects in banked attitudes by banking the aeroplane and move the control column forwards and backwards. Point out that relative to the aeroplane the same pitching movements are produced. When in a banked attitude vary the bank angle to show that while doing this the wing tip movements are still relative to each. Apply rudder in both directions and show that relative to the aeroplane the same yawing movements are produced.



SECONDARY EFFECT OF FLYING CONTROLS

Elevator Demonstrate by raising and lowering the nose to a greater divergence from level flight than in the initial demonstration.

Ailerons Advise the student that your feet are on the floor and not on the rudder pedals, Apply aileron, point out that the aeroplane commences to roll, then because of the resulting slip, the nose yaws towards the lower wing tip. Continue the application of aileron until a definite yaw and lowering of the nose position is noticed by the student. Do not continue the demonstration to the extent that a steep spiral dive might cause some discomfort or anxiety to the student. After recovery to level flight allow the student to experiment with the manoeuvre (initiation and recovery) in both directions.*

Rudder Advise the student that your hand is deliberately not on the control column. Apply rudder, point out that the aeroplane commences to yaw and because of the yaw, commences to roll in the same direction. The nose will continue yawing towards the lower wing tip below the horizon and because of this the aeroplane will continue to roll. Do not continue the demonstration to the extent that the resultant steep spiral dive might cause some discomfort or anxiety to the student. After recovery to level flight allow the student to experiment with the manoeuvre (initiation and recovery) in both directions.*

*The instructor should advise the student when to commence the recovery.

EFFECT OF AIRSPEED

Place the aeroplane in a slight descent at an IAS just below the top of the green arc on the ASI and ensure the aeroplane is correctly trimmed. Hand the aeroplane over to the student and allow him or her to gently experiment by moving all flight controls individually then collectively.

Repeat the exercise at an IAS about 15 knots above the stall speed.

Following the high and low speed exercise quiz the student on the feel of the controls in both speed ranges.

EFFECT OF SLIPSTREAM

Set the aeroplane up in a normal climb with high power. Hand the aeroplane over to the student in a trimmed condition and ask him or her to feel the effect of each control individually.

Resume control and without unsettling the student with the relatively large pitch change commence a glide at the same speed that was used for the climb. Hand the aeroplane over to the student in a trimmed condition and ask him or her to feel the effect of each control individually.

Following the climb and descent exercise quiz the student on the feel of the controls in both parts of the exercise.

EFFECT OF TRIM

Place the aeroplane in straight and level flight, correctly trimmed. Point out the attitude of the aeroplane and tell the student to keep the aeroplane in exactly that attitude even though he or she is about to feel very heavy loads on the controls. When the student has settled down and is holding the attitude reasonably well, move the elevator trim and point out the increasing load on the control column. Have the student move the trim to relieve this load. Repeat the exercise moving the trim in the other direction.

Repeat the demonstration for the rudder and aileron trims if applicable. Allow the student to experiment with the trims until the student is reasonably confident in their use.

Ensure that the student appreciates the sense of trim control movements and that the aeroplane will remain in the selected attitude when accurately trimmed. Ensure too, that the student understands that changes of trim may occur with changes of power, airspeed, flight configuration and loading.

Note: Many students are beginning to tire by this stage of the exercise and it may be prudent to terminate the flight at this point and continue the exercise later.



ENGINE CONTROLS

Throttle Point out the red line on the tachometer and reaffirm that that RPM must never be exceeded and if it is exceeded it must be reported.

Give the student control of the 'throttle only' and have the student set various RPM.

Demonstrate that the RPM of a fixed pitch propeller varies with IAS. Set a mid range RPM and vary the airspeed to show RPM changes.

Mixture control Indicate that in the early part of the training the mixture will usually be set at full rich. However, a demonstration of leaning the mixture is usually worthwhile.

Carburetor heat control Demonstrate use of the control, when it should be used and allow the student to practice.

Engine cooling devices If fitted, explain and demonstrate use.

Engine control friction Demonstrate use and allow student practice.

Fuel system If applicable demonstrate use of the auxiliary fuel pump, changing fuel tanks and instrument indications.

EFFECT OF FLAPS

Point out to the student the maximum speed for lowering flaps. Fly just below this speed and lower the flaps partially. Point out the effect on trim, nose position and speed. Repeat the demonstration using full flaps. Raise the flaps in stages, re-trimming as necessary. Next fly at a low airspeed with flaps fully lowered. Raise all the flaps as rapidly as possible, pointing out the resulting sink and change of trim. Stress that this is the reason why with most aeroplanes the flaps must be raised in stages.

COMMON FAULTS

The most common faults are that the student:

- Is too tense and does not hold the controls correctly. Several attempts are often necessary to convince the student that a light touch is essential
- Fails to lookout prior to manoeuvring – constant reminders may be necessary and the instructor must be exemplary in this matter

A common instructional fault is that this sequence is too often rushed through with insufficient time allowed for the student to appreciate the feel of the aeroplane. At the completion of this exercise a student should be able to place the aeroplane in any desired attitude in the pitching plane, while maintaining a constant heading with wings level. If the student cannot do so then more time should be taken before proceeding to the next sequence.



05 STRAIGHT AND LEVEL FLIGHT

AIM

To teach the student how to fly the aeroplane in straight and level flight at varying airspeeds.

INSTRUCTIONAL GUIDE

Figure 5-1 provides a basis for the briefing. Before the flight ensure that the student has received a briefing and has grasped the fundamentals of this exercise. Ensure that the student is aware of the way in which to move the controls to maintain and regain this condition of flight. Also stress again the importance that you will place on trimming during the exercise.

Choose smooth flying conditions for this exercise and if there is significant wind at the operating altitude conduct the exercise into wind or down wind. Additionally, there needs to be an easily definable horizon.

During the flight stress the attitude of the aeroplane with reference to the natural horizon. Show the student how to pick some reference point on which to keep straight and assist in the initial stages to decide when the wings are, in fact, level. Show the student how to detect out-of-balance flight and how to correct this. Demonstrate to the student that if his wings are level and the balance ball is, say, over to the left, a slight pressure on the left rudder will correct the unbalanced state. Later on when power changes are being made, ensure that the student corrects for the resultant yaw and pitch changes.

Instruct the student to keep a good lookout and point out prominent landmarks in the ongoing process of orientation training.

As the student becomes more proficient draw attention to the flight instruments. Show how their indications are directly related to the attitude of the aeroplane in relation to the horizon. Do this in all exercises from now on. Remember to impress on the student the need for a good lookout. Do not let the student get a 'head in the cockpit' complex.

Ensure the student is correctly trimming the aircraft by occasionally asking for 'hands off flight.' If rudder trim is fitted a similar exercise can be conducted for checking on balance.

PRE-FLIGHT BRIEFING CONSIDERATIONS

Figure 5-1: Lift formula

$$L = C_L \frac{1}{2} \rho V^2 S$$

During straight & level flight

$$W = L = C_L \frac{1}{2} \rho V^2 S$$

$$= C_L \frac{1}{2} \rho V^2 S$$

Pilot has no control over circled items (ignoring use of flap)

- C_L = coefficient of lift
- ρ = air density
- S = plan area of wing
- V = velocity
- W = weight

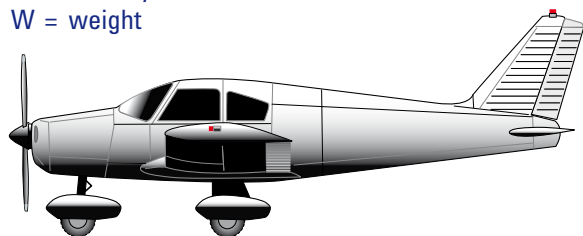

Straight & level at low speed

$$C_L \uparrow \quad V^2 \downarrow$$

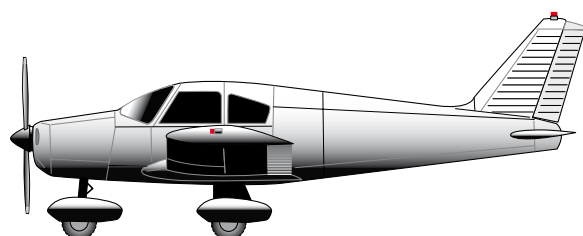

Straight & level at high speed

$$C_L \downarrow \quad V^2 \uparrow$$



FORCES ACTING ON THE AEROPLANE

Explain that there are four forces acting on the aeroplane in balanced straight and level flight, namely, Lift - Thrust

-Weight and Drag.

LIFT

Explain how lift is derived from an aerofoil, emphasizing the factors which can be controlled by the pilot, i.e., airspeed and angle of attack.

POWER

Tell the student the recommended power setting to be used for normal cruise flight. Explain that the amount of power available is the governing factor for both the maximum and minimum speeds at which the aeroplane may be flown in level flight.

STABILITY

Explain how the aeroplane is made stable in all three planes i.e.

Longitudinal - tail plane

Lateral - dihedral (or high wing low centre of gravity)

Directional - keel surface

TRIMMING

Explain again the operation and use of all trimming devices. Stress again that the correct technique is to hold the selected attitude and then trim to relieve the control load.

USE OF CONTROLS IN STRAIGHT AND LEVEL FLIGHT

Explain to the student how to judge the correct attitude in respect of the nose and wing tips position relative to the horizon. Explain the use of the elevators and how the wings must be kept level with ailerons and the rudder used to keep the aeroplane balanced.

INSTRUMENTS

Briefly explain the instrument indications relating these indications to aeroplane attitude with respect to the natural horizon.

APPLICATION IN FLIGHT

Brief the student on the particular phases of straight and level flight you intend to teach during the particular lesson. Ensure that the student is aware of the sequence of events to achieve these particular conditions. This is normally to set the selected power, assume the correct attitude, trim, then readjust as necessary. Explain that this sequence may vary, e.g. from the climb to straight and level flight, the attitude is first selected then power, then trim.

AIRMANSHIP

Stress that a good lookout must be maintained at all times. Keep a check on the aeroplane's position throughout the flight.

AIR EXERCISE

- (a) Attitude, balance, trim
- (b) Straight and level flight at various power settings
- instruments

ATTITUDE, BALANCE, TRIM

Firstly demonstrate straight and level flight with the aeroplane in a normal cruise configuration. Point out the attitude (i.e. sight picture) in relation to the horizon. Show how to maintain this attitude with the elevator control. Ensure that the student is aware of the trimming procedure and that he or she is able to trim the aeroplane to fly 'hands off'.

Next, point out the position of the wing tips in relation to the horizon but then explain it is far easier to gain the required sight picture by having part of the aeroplane structure parallel to the natural horizon. Show how to maintain this position with the ailerons. Help the student choose a point on which to keep straight. Demonstrate that if the wings are kept level, small movements of the rudder will keep the aeroplane straight. Point out the balance of the aeroplane. If the aeroplane is fitted with a rudder trim, ensure that the student uses this in the correct sense.



At this point in the lesson it is invariably beneficial to demonstrate to the student grossly exaggerated crossed controls (not followed by student practice). Note the IAS prior to crossing the controls and maintain a constant altitude. Explain to the student that the net flight path of the aeroplane is straight but the wings are certainly not level. Also point out the reduced IAS (i.e. inefficient form of flight) and the manoeuvre is uncomfortable. Then reduce the bank angle considerably and explain that whilst this may not feel uncomfortable to a student it certainly is uncomfortable for an experienced pilot.

Next allow the student to use all controls and impress that in smooth air the movements of the control surfaces are so small that it is more a question of applying pressures rather than moving the controls.

The student is likely to have deviated from the nominated height and direction during the above practice. In this early stage of training it is often helpful to make height corrections first and then direction corrections until more proficiency is gained. The instructor can then demonstrate how to make the corrections

As the student becomes more proficient take control and alter the attitude, trim and power setting, then tell the student to regain straight and level flight.

Frequently the following exercise, similar to the above, is helpful. Tell the student that you want a new height (higher or lower by up to 200 FT) and a new direction (up to 20 degrees off the current heading).

Allow ample student practice of the above exercise(s) prior to continuing the lesson.

Now demonstrate the effect of power changes on pitch and yaw. In some low powered training aeroplanes this demonstration can be less than convincing! Start from straight and level at a low power setting and in a trimmed condition rapidly apply full power. Induce the pitch and roll if necessary as you take your hands and feet off the controls. Set the aeroplane up as previously advised and close the throttle quickly and induce the effects if necessary.

STRAIGHT AND LEVEL FLIGHT AT VARIOUS POWER SETTINGS – INSTRUMENTS

Commence this demonstration from straight and level flight at normal cruising power. Point out the airspeed, attitude and height. Impress upon the student that this height is to be maintained exactly. Now show how to increase power to maximum continuous. Point out

that the aeroplane increases speed and tends to climb. Show that this tendency to climb must be countered by lowering the nose position in relation to the horizon. Re-trim the aeroplane. Impress upon the student the different sight picture from straight and level at normal cruise power. Ensure that the student corrects for yaw when altering power settings.

Point out that the indications of the instruments are now different from the normal cruise straight and level indications. Relate these readings directly to the aeroplane's different attitude, especially the lower nose position.

Now fly straight and level and show the power reduction for normal cruise. When settled demonstrate the effect of reducing power. Ensure that the power selected is still sufficient to maintain height. Point out that the aeroplane will yaw as power is decreased, keep straight with rudder. Show that it will lose height unless the attitude is changed to give a higher nose position. Point out the decreased airspeed and the need to re-trim.

Bring the student's attention to the flight instruments showing that their indications are once again related directly to the aeroplane's new attitude, especially the high nose position.

Demonstrate that when the power is reduced below a certain amount the aeroplane is unable to maintain height.

COMMON FAULTS

Many students tend to fly in a continual state of out-of-balance flight. This is almost invariably due to the wings not being level. The result is that the student uses rudder thus crossing the controls in attempting to keep straight.

Students often require much prompting before they will satisfactorily eliminate yaw whilst changing power.

Do not allow the student to change attitude by using the trimming controls.

Some instructors rush this exercise, which can result in students having difficulties for the remainder of their training and beyond.



06 CLIMBING

AIM

To teach the student how to climb the aeroplane at a given airspeed and power setting.

Note: For practical and economic reasons the brief on descending should follow this brief as the airborne exercises are usually combined.

INSTRUCTIONAL GUIDE

Before taking the student into the air ensure that he or she has a basic understanding of the practical considerations of the various methods of climbing you intend to teach during the particular lesson.

The student must be aware of the effect of changing power, the power settings to be used for the various climbs, the recommended airspeeds for these climbs, the effects of flap and its use during the climb and engine limitations. Also explain the forces acting on an aeroplane during the climb—figure 6-1 refers.

During the flight emphasis the importance of the climb attitude. By making small adjustments to this attitude an accurate climb speed can be maintained.

Do not allow the student to climb in a straight line for too long if the particular aeroplane has a blind spot under the nose. Show the student how to change heading or lower the nose at intervals to ensure that this blind spot is clear then resume the original heading.

Often students encounter difficulty when leveling off after a climb. Do not expect the student to be very accurate at this manoeuvre during the early stages.

Ensure, however, that the student is anticipating the altitude required, as a guide by 10% of the rate of climb. Holding the aeroplane in constantly varying attitudes whilst the speed is building up is frequently a problem. This can be overcome by anticipating and making the approximate trim change that will be required when straight and level is achieved.

PRE-FLIGHT BRIEFING CONSIDERATIONS

FORCES ACTING UPON THE AEROPLANE

Brief the student on the distribution of the forces acting on an aeroplane during the climb.

Figure 6-1: Forces acting on an aeroplane during climb

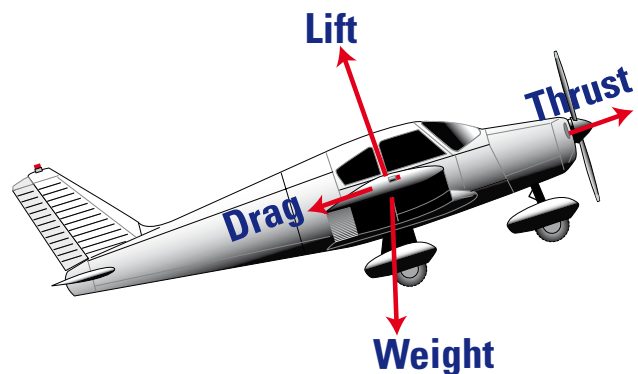
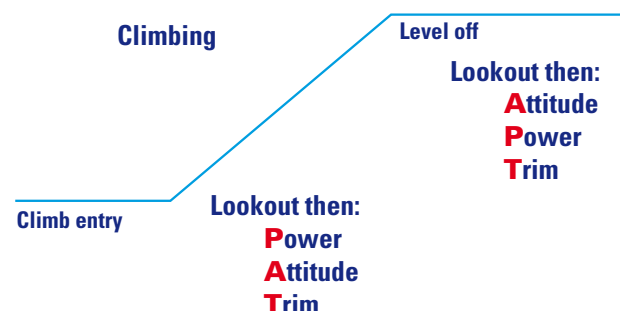

Figure 6-2: Sequence for entering a climb and levelling off





BEST CLIMBING SPEED

Show that this depends on the power available and the power required to result in a certain airspeed. Explain that recommended climbing speed is often higher than the theoretically best speed, thereby giving better engine cooling and visibility.

EFFECT OF FLAP

Show that the increase in lift at lower speed gives a greater climb angle. However, the increased drag gives a reduced rate of climb.

PARTICULAR FEATURES OF THE AEROPLANE TYPE

Explain any particular features of the aeroplane type to assist the pilot during a climb like an offset fin or rudder bias. Tendency to yaw must be corrected with rudder.

APPLICATION IN FLIGHT

Brief the student on the particular types of climb to be taught during the lesson i.e. normal climb, maximum rate climb and maximum angle climb. Explain the sequence of events for entering a climb, being Power - Attitude - Trim (see Figure 6-2). Ensure that the student is aware of the required power settings, approximate attitude, speed and if needed during the maximum angle climb, the flap setting to be used.

To return to straight and level flight the sequence is normally Attitude (constantly varying until the required speed is obtained) Power then Trim.

AIRMANSHIP

As always, a good lookout is to be maintained.

Do not climb in a straight line for too long - clear the blind spot approximately every 500FT.

Engine handling—stress temperature control and the use of the mixture control and the carburettor heat control.

AIR EXERCISE

- (a) Normal climb - how attained
- (b) Climbing at maximum rate
- (c) Climbing at maximum angle
- (d) Effect of flaps on the climb

NORMAL CLIMB

Demonstrate the normal climb using the recommended climbing speed and power setting.

Firstly ensure that the area into which you are about to climb is clear. Apply climb power, preventing yaw with rudder and place the aeroplane into the estimated climbing attitude. Allow it to settle and check the speed. Adjust the attitude and trim as necessary. Impress upon the student that after each attitude adjustment the air speed is allowed to settle before any further adjustment.

Check that the wings are level and that the aeroplane is balanced. This is done by reference to the balance indicator. Check the trim and point out that if it is not fitted with a rudder trim it will be necessary to keep a pressure on one of the rudder pedals in order to keep straight and to balance the aeroplane.

During the climb, point out the indications of the various flight instruments. Relate these indications directly to the attitude of the aeroplane in relation to the natural horizon.

Point out that the view ahead is restricted and show how to periodically alter heading (or lower the nose)* to ensure the aeroplane is climbing into a clear area.

Note: *This method is least preferred as students often experience difficulty keeping the aeroplane balanced and resuming the desired climb speed.

Bring to the student's attention the engine instruments. Demonstrate the use of cowl flaps or other cooling devices if fitted. Advise that if overheating does occur it can normally be stopped by changing the attitude to climb at a slightly higher airspeed. If this remedy is not effective a reduction in power together with a higher airspeed or even a period of straight and level flight may be necessary until the temperatures are back within the limits.



Demonstrate level off from the climb. Anticipate the desired height by commencing the level off by about 10% of the climb rate. Keep the aeroplane balanced by use of rudder and progressively lower the nose by movement of the control column. Anticipate the amount of trim required and apply it. Reduce to cruise power as the desired IAS approaches and accurately re-trim the aeroplane. Then check the height to see that it is remaining constant. If it is not, adjust power, attitude and re-trim as necessary to maintain straight and level flight.

As the student becomes competent with entering the climb and leveling off, climbing rate one turns can be introduced as an extension of the lookout procedure.

CLIMBING AT MAXIMUM RATE

Demonstrate this exercise using the same techniques as with the normal climb demonstration but with the power setting, normally full power, and airspeed recommended for the maximum rate climb. This demonstration should be carried out at an altitude low enough to make a convincing comparison with the normal climb. Point out to the student the higher nose position, the increased rate of climb and the indications of the flight instruments, these indications being related directly to the high nose position of the aeroplane. Make sure the student is aware of engine limitations. Point out that there may be a time limit for the use of this power setting.

On some light aeroplanes the demonstration of the difference between the maximum rate of climb and the normal recommended climb may not be very convincing.

If using one of these aeroplanes the instructor should use discretion as to whether the demonstration should be given.

CLIMBING AT MAXIMUM ANGLE

This climb should be demonstrated at a reasonable altitude and then later on immediately after a short take-off when the student has progressed to that stage. Full power is normally used together with a lower airspeed than that used for the maximum rate climb. On many aeroplanes the use of flap, lowered to the optimum setting is recommended.

Point out to the student the high nose position in

relation to the horizon. Relate the indications of the flight instruments directly to this steep attitude. Point out the engine limitations to the student and make him or her aware that this type of climb is rarely a prolonged one since it is used only long enough to clear any obstructions, a normal climb then being resumed.

EFFECT OF FLAPS ON THE CLIMB

A prolonged climb with flaps extended should never be required. However, a student must be taught how to initiate a climb with flaps extended and be made aware of the effect of the drag of this component on the climb.

Demonstrate this exercise from a normal climb. At a suitable speed lower the flaps to the optimum setting. Point out the attitude and decreased rate of climb. Show too, that the airspeed to give the best rate of climb for this configuration is lower than normal. Point out the indications of the flight instruments, relating these directly to the attitude in relation to the horizon. Then lower full flap. Show the change of attitude and point out that the rate of climb is further decreased. Now show how to resume a normal climb. Raise the flaps to the optimum setting increasing speed towards normal climbing speed. At a safe height and speed raise the flaps completely and resume normal climbing.

COMMON FAULTS

The student often fails to correct for yaw when changing power, therefore teach to anticipate this problem.

In concentrating on flying the aeroplane, students tend to forget to clear the blind spot created by the high nose position.

Students also tend to forget engine limitations. Accordingly, it is often taught to check the temperatures and pressures immediately before or after clearing the nose every 500FT in the climb.

If a student tends 'to chase airspeed' in the climb (or cannot climb at the nominated IAS) it may well be that the student is not trimming the aeroplane correctly or changing the attitude with trim.



07 DESCENDING

AIM

To teach the student how to descend the aeroplane at given airspeeds, rates of descent and power settings.

Note: For practical and economic reasons this brief should follow the brief on climbing as the airborne exercises are usually combined.

INSTRUCTIONAL GUIDE

Before the flight you must ensure that the student is aware of the practical considerations of the various types of descent you intend to teach him during the particular lesson and the sequence of entering and levelling off – Figure 7-1 refers.

Brief the student on points on to be covered and ensure the student is aware of the effect of changing power, the recommended airspeeds for the various descents about to be taught, the effect of flap and the effect of wind in terms of distance covered. Also brief the student on the forces acting on the aeroplane during descent, Figure 7-2 shows the forces acting during a glide.

Stress again engine handling, explaining the use of cowl flaps and cooling devices if fitted, the use of carburetor heat and the necessity to keep the engine ready for instant response by use of cruise power for a few seconds every 1,000FT.

During the flight make sure that the student keeps a good lookout and point out the blind spot under the nose, showing how to ensure that all is clear ahead. In so doing an introduction to 30 degree banked descending turns can be given as an extension of the lookout procedure.

When demonstrating the use of the flaps you may find that the student will not anticipate the change of trim. Explain these effects as they apply to the particular aeroplane being used.

As in the climbing exercise you may find that the student is not anticipating the height at which he requires to assume level flight. Point out that the recovery to level flight should start at about 10% of the descent rate above the required height.

As the student becomes more proficient give plenty of practice in descending at given rates of descent at a constant airspeed.

PRE-FLIGHT BRIEFING CONSIDERATIONS

FORCES ACTING ON THE AEROPLANE

Explain that the forces acting in a glide are lift, drag and weight. Show that the resultant of lift and drag is equal and opposite to the weight of the aeroplane.

Figure 7-1: Method of entering a descent and levelling off.

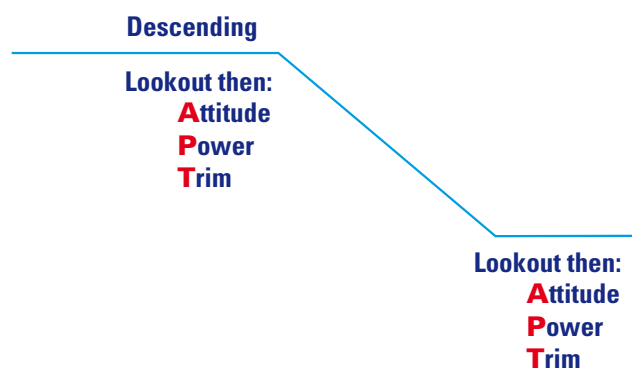
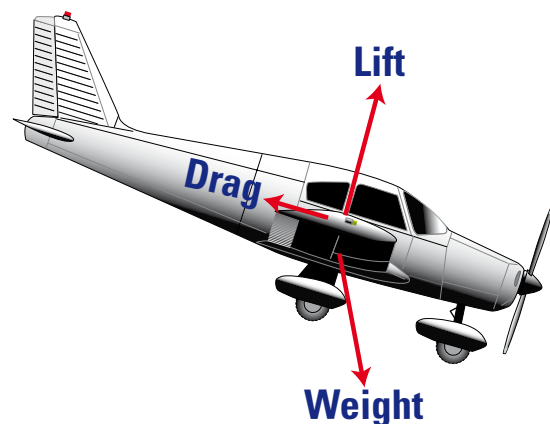

Figure 7-2: Forces acting on an aeroplane during a glide.





BEST GLIDING SPEED

Explain that at this speed the angle of attack is such that the lift/drag ratio is at a maximum.

EFFECT OF FLAP

Lowering flap increases lift for a given airspeed but also increases drag. The lift/drag ratio is always decreased. This results in an increased rate of descent. The lower nose position for a given speed should also be stressed.

EFFECT OF WEIGHT

Weight does not affect the gliding angle providing the speed is adjusted to compensate for the changed weight.

EFFECT OF WIND

The distance an aeroplane can glide from a given height is affected by wind. Gliding into wind - distance decreases. Down wind - distance increases.

EFFECT OF POWER

For a given airspeed the rate of descent varies with the power setting. The greater this power setting the lower the rate of descent.

PARTICULAR FEATURES OF THE AEROPLANE TYPE

The tendency of an aeroplane to yaw is corrected by such means as an offset fin or by rudder bias.

APPLICATION IN FLIGHT

Brief the student on the particular types of descent to be carried out during the lesson. Ensure that he or she is aware of the approximate attitudes, speeds and where applicable, flap settings to be used.

In the powered descent stress that airspeed is usually controlled with elevator and rate of descent with the throttle.

To recover to straight and level flight the normal sequence of events is Attitude, Power and Trim.

AIRMANSHIP

Check that the area into which the descent is to be made is clear. Apply cruising power at least every 1,000FT of descent and emphasize the necessity of closely managing engine temperature during a prolonged descent. Apply carburetor heat prior to closing the throttle if it is considered that atmospheric conditions are conducive to the formation of carburetor ice.

AIR EXERCISE

- (a) Descent without power - gliding - how attained
- (b) Effect of flaps
- (c) Effect of power

DESCENT WITHOUT POWER

The first demonstration should be the entry and maintenance of a flapless glide using the recommended airspeed. This should be done from straight and level flight.

Firstly ensure that the area into which you are about to descend is clear. Close the throttle, preventing yaw with rudder. Hold the straight and level attitude until the speed approaches the desired gliding speed, then select the appropriate gliding attitude and hold this constant. Trim the aeroplane. When the aeroplane has settled check the airspeed and adjust and re-trim if necessary. Check that the wings are level and that the aeroplane is descending on a constant heading with the balance indicator central.

During the glide point out the instrument indications to the student. Show how these readings are related directly to the attitude of the aeroplane. Bring the student's attention to the engine limitations and controls, carburettor heat, cowl flaps etc. Show the student how to clear the engine and keep the temperatures within the operating range so that it is ready to respond instantly when required. Point out the blind spot caused by the nose of the aeroplane and teach the student how to ensure that the area into which the aeroplane is descending is clear.

In teaching the student how to resume straight and level flight, show how to anticipate the required height. Progressively raise the nose to the appropriate attitude as power is increased, keeping the aeroplane balanced throughout then wait for the speed to settle. Check that the speed is correct, that the wings are level and that the balance indicator is central. Trim the aeroplane. Check the height and adjust as necessary for straight and level flight.



EFFECT OF FLAPS

Commence this demonstration from a flapless glide at the normal recommended speed. Point out the attitude and rate of descent in this configuration.

Lower partial flap and settle the aeroplane at the same airspeed. Point out the lower nose position and the slightly higher rate of descent.

Lower the flap in stages, settling the aeroplane at the same airspeed at each stage. Point out that increased flap results in a lower nose position and greater rate of descent. Impress these attitudes on the student and point out the instrument indications at all stages, showing particularly the interpretation of the low nose position from the instruments.

EFFECT OF POWER

Demonstrate the effect of power from the glide at a constant airspeed.

Point out the attitude of the aeroplane and rate of descent in the glide. Increase power to a suitable figure keeping the airspeed constant. Point out the higher nose attitude and the decreased rate of descent. If particularly noticeable show too that engine temperatures do not fall to below the normal operating range.

Demonstrate to the student how the rate of descent can be varied by use of power whilst keeping the airspeed constant.

Make sure that the student is convinced by demonstration that in these circumstances the elevators are used to control the airspeed, and power the rate of descent. Ensure that the student is aware that changes in the rate of descent, i.e. variations in power, necessitate changes of attitude to keep the airspeed constant.

COMMON FAULTS

In attempting to set up a glide, a student often tends to go on for too long at the same airspeed. If this happens, tell the student to make a conscious effort to keep the nose in the level attitude until almost at the required speed.

Often the student does not let the aeroplane settle down in the various configurations. This results in chasing the airspeed. The cure for this is to impress the various attitudes on the student's mind and to make the student wait until the aeroplane is settled before altering these attitudes.

Students also frequently forget to clear the blind spot in the descent and do not apply cruise power every 1,000FT to manage engine temperatures.



08 TURNING

AIM

To teach the student to carry out various types of turn and how to turn accurately towards features and on to specified headings.

INSTRUCTIONAL GUIDE

Whilst several types of turn are dealt with in this exercise it will obviously be impossible to teach all these types in one lesson. However, before first solo the student must be competent in performing medium level turns, medium descending turns, both with and without power, and climbing turns. The more advanced types of turns should be introduced after first solo.

Turns are often described as gentle, medium and steep according to the angle of bank used. A turn at an angle of bank of much less than 30° is considered as a gentle turn, one at about 30° a medium turn, and one at 45° or more as a steep turn.

In making an accurate turn an experienced pilot co-ordinates all three main controls so that a smooth, balanced turn results. A student often finds difficulty in doing this, therefore it is better for a student to think of each control as having one definite function during the turn with the ailerons controlling the angle of bank, the elevators controlling the position of the nose relative to the horizon and the rudder balancing the aeroplane, preventing or correcting any slip or skid.

Before flight make sure that the student is aware of the principles of turning, the use of controls, the use of power and the various angles of bank and the speeds and attitudes to be employed in the particular types of turns to be taught during the air exercise.

During the flight the initial emphasis should be placed on the correct judgment of attitude and angle of bank by reference to the natural horizon. As the student becomes more proficient he or she should be made to cross refer to instruments to achieve greater accuracy. It must be stressed that a good lookout is essential both before and during a change of direction.

In aeroplanes with side by side seating, point out to the student the different nose position relative to the pilot when carrying out turns in opposite directions.

PRE-FLIGHT BRIEFING CONSIDERATIONS

MEDIUM LEVEL TURNS

Definition A medium turn is one carried out with an angle of bank of approximately 30 degrees.

Explain to the student the forces acting on an aeroplane during a medium level turn.

Figure 8-1: Forces acting on an aeroplane during a level turn.

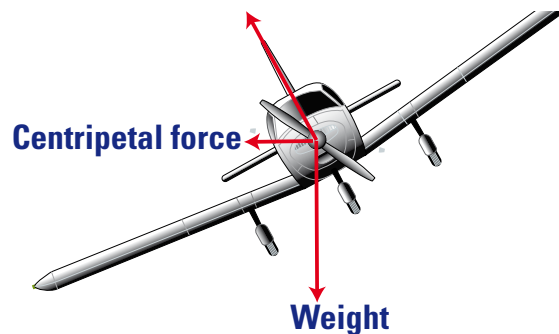

Explain why the aeroplane is banked, ensuring that the student appreciates that the lift must be greater than the weight in order to support the weight and provide the horizontal component to turn the aeroplane – see Figure 8-1.

Explain how to balance the aeroplane with rudder.

Explain the tendency to over bank if this tendency is noticeable on the type of aeroplane in use.

Explain the effect of aileron drag if this is applicable to the type of aeroplane and how it will be demonstrated in flight.

Emphasize how the aeroplane is controlled:

- (a) Angle of bank - ailerons
- (b) Nose position in relation to the horizon - elevator
- (c) Prevention or correction of slip or skid (balance) – rudder



APPLICATION IN FLIGHT

Brief the student on the entry to the turn, the approximate nose position relative to the horizon and the way to maintain the turn. Give an appreciation of the instrument indications that may be anticipated, particularly with reference to the ASI, altimeter, turn and balance indicator and attitude indicator. Explain to the student how to recover from the turn.

AIRMANSHIP

It is essential to keep a good lookout for other aircraft.

CLIMBING TURNS

Explain that the forces acting on an aeroplane during a climbing turn are similar to those in a straight climb except that the aeroplane is banked.

Point out that the angle of bank is restricted to only about a rate one turn, otherwise the rate of climb is decreased markedly.

Explain that there may be a tendency to over bank during the climbing turn. This is due to the outer wing moving faster than the inner and to it also having a larger angle of attack than the inner wing. However, this tendency is not apparent in most modern designed aeroplanes

APPLICATION IN FLIGHT

Explain that a climbing turn is carried out in a similar fashion to a medium level turn except that climbing power is used and the nose position is higher. Ensure that the student is aware of the correct airspeed and power setting for the exercise.

AIRMANSHIP

The same considerations apply as in medium level turns.

DESCENDING TURNS

Explain that the forces acting on an aeroplane during descending turns are similar to those in a straight descent except that the aeroplane is banked.

Explain that there is usually no tendency to over bank. This is due to the extra lift the outer wing derives from its extra speed, being compensated for by the inner wing having a greater angle of attack.

The rate of descent can be controlled over a wide range by the use of power. Emphasize that where power is used to control the rate of descent the correct airspeed is maintained by use of the elevator.

APPLICATION IN FLIGHT

Explain the method of carrying out a gliding turn. The method is similar to that used to carry out a medium level turn except that no power is used and the attitude is such that the nose is normally appreciably below the horizon. Explain the use of the flaps if applicable pointing out that when they are used the nose position will be well below the horizon to maintain the required speed. The recovery from the gliding turn is similar to the recovery from a level turn, except that the gliding attitude must be maintained. Brief the student on the use of power to regulate the rate of descent. Ensure that there is no doubt regarding the speeds, flap settings, approximate attitudes and power settings to be used during the exercise.

STEEP LEVEL TURNS

Definition A steep turn is one carried out with an angle of bank at or in excess of 45 degrees.

Explain with diagrams the forces acting on the aeroplane in a steep turn. Show the variation of the forces with the steepness of the turn.

Explain that there are greater loads on the aeroplane and that the student will feel an apparent increase in weight i.e. 'g' loading.

The stalling speed is higher due to increased loading. The increase is proportional to the square root of the wing loading.

The maximum angle of bank is determined by the amount of power available.

APPLICATION IN FLIGHT

The steep turn is carried out in the same way as a medium level turn except that the angle of bank is greater and power is increased progressively to counter the increased drag and thus maintain speed. Emphasize that there will be a greater back pressure required on the control column. This back pressure also increases the rate of turn. The controls are used to maintain the turn in the same way as for a medium level turn except that it may be necessary to decrease the angle of bank in order to raise the nose if it is allowed to get too low. This procedure should be explained to the student.

Recovery is as for medium level turns but emphasize that a positive forward pressure on the control column will probably be required to maintain the correct attitude. Power must be decreased to the normal cruising setting.



AIRMANSHIP

In some aeroplanes the visibility during steep turns may be restricted, therefore, extra care must be taken before entering the turn to ensure that all is clear. In some high wing aeroplanes it may be advantageous to raise the wing in the direction of turn to see that all is clear prior to entry.

With the use of high power, engine temperatures should be closely watched to ensure that limits are not exceeded. Handling of the engine controls should be smooth.

STEEP DESCENDING TURNS

Explain that the forces acting on an aeroplane during a steep descending turn are similar to those in a medium descending turn except that a higher angle of bank and higher airspeed is used. This results in higher loads being imposed on the aeroplane and also the pilot.

The steep nose down attitude causes difficulty in estimating the gliding attitude, cross reference to the instruments is therefore necessary to ensure accuracy. Brief the student on the indications of the flight instruments to be anticipated.

APPLICATION IN FLIGHT

The steep descending turn is carried out in the same way as a medium descending turn except that the angle of bank is greater and a higher airspeed is used. Brief the student to anticipate the need for a positive back pressure on the control column during the manoeuvre. If the airspeed is allowed to increase excessively it will be necessary to decrease the angle of bank before attempting to raise the nose.

Recovery is as for a normal gliding turn. In addition the nose of the aeroplane must be raised to assume the correct gliding attitude and speed.

AIRMANSHIP

Owing to the high rate of descent and poor visibility in some types of aeroplanes, it is essential to ensure that the area into which descent is to be made is clear.

Engine temperatures should be closely monitored as they may fall well below operating range on prolonged descents. Unless other requirements are specified, the throttle should be opened to cruising power every 1,000FT during a prolonged glide.

MAXIMUM RATE AND MINIMUM RADIUS TURNS

In this exercise the aeroplane is being flown at the threshold of the stall. It is therefore turning at the greatest rate possible for the amount of power being used.

When full power is used the aeroplane is being flown to its limit and it is turning at the maximum rate possible. Similarly, with take-off flap selected the aeroplane is turning at the minimum radius possible.

APPLICATION IN FLIGHT

These turns are usually only for extreme traffic avoidance in civil flying but are a good exercise in co-ordination and as an illustration of the limit to which the aeroplane may be flown.

Brief the student that the execution of these turns are similar to the steep level turn except that a strong backward pressure on the control column will be needed to achieve the maximum rate of turn especially when maximum power is used. The student must be aware that this back pressure must be released as the aeroplane starts to buffet and the aeroplane flown right at the threshold of, but not at, the stall. Recovery is as from a steep level turn.

Any tendency towards loss of control must be corrected immediately. This is normally achieved by releasing the back pressure on the control column and decreasing the angle of bank with ailerons.

AIRMANSHIP

As with all other exercises a good lookout must be maintained during the whole exercise.



TURNING ON TO COMPASS HEADINGS AND TIMED TURNS

Explain to the student that in general the magnetic compass will only give an accurate indication when the aeroplane is flown in un-accelerated flight.

The errors which are inherent in simple magnetic compasses are caused by the compass needle taking up a position not parallel to the earth's surface. Explain how off-setting the pivot point of the magnet system in relation to its centre of gravity will reduce the effect of magnetic dip.

Explain turning errors in the Southern hemisphere. When turning on to northerly headings the magnet system will be 'lively' and when turning on to southerly headings it will be 'sluggish'. Therefore overshoot when turning on to northerly headings—undershoot on southerly. Point out that the greater the rate of turn the greater will be the degree of undershoot or overshoot.

Explain the acceleration errors when flying on easterly or westerly headings. When increasing speed on these headings an apparent turn to the South results. When decreasing speed on these headings, an apparent turn to the North results.

Explain that both turning and acceleration errors are at a maximum on the cardinal points, and that the direction of these errors is reversed in the Northern hemisphere.

In turbulence it is sometimes easier to mentally calculate the angular change required, divide by 3 and fly the resultant figure in seconds at rate one in the required direction.

APPLICATION IN FLIGHT

Ensure the student is competent at performing level turns on to geographic features prior to introducing turns on to specific headings. Emphasize that such turns are carried out normally at less than rate one and that steady un-accelerated flight is essential if accurate indications are required. Teach the student how to estimate the number of degrees through which to turn, then to turn with reference to the horizon then to check, the heading with the compass. Very small corrections of only a few degrees require only a very small angle of bank and may even be corrected with rudder. In these circumstances the bank angle should amount to approximately half of the angular change.

Timed turns are conducted as earlier explained.

AIRMANSHIP

Whilst using the compass for heading reference the need for a good lookout must not be forgotten.

AIR EXERCISE

- (a) Medium turns in level flight
- (b) Climbing turns
- (c) Descending turns
- (d) Steep level turns
- (f) Steep descending turns
- (g) Maximum rate & minimum radius turns
- (h) Turning on to compass headings and timed turns

MEDIUM TURNS IN LEVEL FLIGHT

Prior to commencing the exercise it is essential to demonstrate adverse aileron yaw. If the demonstration has previously been given a refresher demonstration may be required. Following a good lookout rapidly apply aileron (no rudder input) and have the student note that initially the nose travels in the opposite direction to the roll. Repeat the exercise in the opposite direction and from a steep turn to wings level.

Initially have the student make all turns at 30 degrees angle of bank through 360 degrees, rolling out on (i.e. pointing at) a geographic feature. Rolling out on a specific heading should be delayed until the student is sufficiently skilled at rolling out on a geographic feature.

If the aeroplane has side by side seating it will be necessary to demonstrate turning in both directions due to the different sight pictures.

Having demonstrated level 360 degree turns in both directions it may be prudent to break up the exercise as follows:

Entry – lookout, apply aileron in the direction of turn, rudder in the direction of turn and back pressure on the control column, centralize the aileron control at the desired bank angle.

During – Control pitch attitude with elevator, bank angle with aileron and balance with rudder

Exit – reverse of entry



GENERAL GUIDELINES ON TURNING INSTRUCTION:

- During a visual turn about 85% of the time should be spent on lookout, 10% of the time checking attitude plus lookout and 5% of the time checking instrument indications

Throughout the turn balance, unlike pitch and bank angle cannot be accurately determined by visual cues

The rate of roll determines the amount of rudder required during the entry and exit i.e. quicker roll = more rudder input

In most light aeroplanes a power increase is not required for level turns of 30 degrees bank or less

Anticipate the roll out by about half the bank angle

For small heading changes use a bank angle of about half the angular change

Ensure practice turns of all types are conducted in each direction as a right handed student will often favor turning left and vice versa

CLIMBING TURNS

From a normal climb, having made sure that all is clear, roll into a turn as it is done from level flight but use only a rate one turn. Keep the bank constant with ailerons, the nose in the correct position with the elevators and use the rudder as a balance control. Point out that the instruments, especially the attitude indicator, show both bank and climb. Emphasize the position of the nose in relation to the natural horizon. Remember it may be more difficult to accurately determine the required attitude picture in a climbing turn compared to a level turn.

Demonstrate that increasing the bank angle reduces the rate of climb.

MEDIUM DESCENDING TURNS

Firstly demonstrate the gliding turn. When gliding in the correct attitude ensure that the area is clear of other aeroplanes. Roll into the turn as for a medium level turn, taking care to maintain the correct gliding attitude.

Recover from the turn as for a recovery from a level turn maintaining the correct gliding attitude at all times.

In aeroplanes fitted with flaps demonstrate gliding turns with these extended. Point out the steeper attitude and also that the rate of descent is much higher than without flap. Recover normally and allow the student to practice these turns until proficiency is achieved.

When the student is able to carry out gliding turns both with and without flaps, teach the student to control the rate of descent by use of power.

Emphasize that the selected airspeed is held constant by use of the elevator and the rate of descent is controlled by use of power. Demonstrate that the amount of power required to maintain a constant rate of descent increases as the angle of bank is increased.

STEEP LEVEL TURNS

Initially demonstrate the steep level turn using 45 degrees of bank. As the student progresses the angle may be increased to 60 degrees. This will probably be the maximum angle at which a sustained steep turn can be satisfactorily demonstrated in most training aeroplanes.

Emphasize a good lookout then enter as for a medium level turn but increase the power progressively as bank increase to overcome the increase in drag. Demonstrate that a greater backward pressure on the control column is required to maintain the correct nose position.

During the turn the controls are used in the same way as in medium turns. Point out that if the nose of the aeroplane is allowed to sink too far below the horizon it will be necessary, first to reduce the angle of bank, and then raise the nose to the correct position.

Point out the high rate of turn and the indications of the instruments.

Recover as for a medium turn pointing out that power must be reduced and that a positive movement forward of the control column is required to maintain the correct nose position in relation to the horizon.



STEEP DESCENDING TURNS

The steep gliding turn should be practiced as this manoeuvre is excellent in producing co-ordination and is a good test of a pilot's ability.

Select a speed some 10 knots above the normal gliding speed, this figure depending on the type of aeroplane. Demonstrate that a steep attitude is necessary to maintain this speed. Should the airspeed increase to too high a figure, demonstrate that it may be necessary to first decrease the angle of bank, and then adjust the airspeed.

During this exercise point out to the student how to interpret from the instruments the steep nose-down attitude, the high angle of bank and the high rate of descent.

MAXIMUM RATE AND MINIMUM RADIUS TURNS

Firstly demonstrate this turn by selecting a low power setting. Enter the turn as normal allowing the bank to increase maintaining the height with a backward pressure on the control column until the judder is felt. Relax the backward pressure just sufficiently to cause the judder to stop. Maintain this attitude and point out the airspeed and rate of turn. The aeroplane is now being flown at the threshold of the stall and therefore is turning at the greatest rate possible for the amount of power being used. Now increase to full power and demonstrate that it is possible to increase the angle of bank and thus move the control column further back before the judder is reached. Fly the aeroplane at the threshold of the stall and point out the increased rate of turn. The aeroplane is now being flown to its limit because this is the maximum rate of turn of which it is capable. Repeat the exercise with an appropriate flap setting and ensure the flaps are not over speed, thus flying a minimum radius turn.

TURNING ON TO COMPASS HEADINGS

Fly on any heading and then commence a rate one turn. Point out that the relative movement of the compass needle is in proportion to the rate of turn. Show that if the bank is increased the relative movement of the compass needle bears no relationship to the actual rate of turn and may even show a turn in the other direction. Emphasize that this demonstrates the importance of turning at a low rate when using the magnetic compass as a directional reference, especially at higher latitudes.

Next fly on a southerly heading and start a turn left or right at rate one on to North. Firstly demonstrate the effect of rolling out of the turn when the compass indicates exactly North. Show that when the aeroplane settles down, the heading will be some 20 to 30 degrees from North. Return to a southerly heading and repeat the turn on to North but this time continue the turn until the compass indicates that the aeroplane has turned approximately 30 degrees past North then roll out and hold the aeroplane steady. When the compass has settled down point out that the aeroplane is sufficiently near the selected heading to allow it to be turned on to North by a small final correction.

Repeat the demonstration, this time turning on to South. Show that in this case and at a higher latitude it is necessary to stop the turn some 30 degrees before the compass indicates South.

Demonstrate that when turning on to East or West, it is possible to stop the turn when the compass reads East or West and that little or no correction will be needed to settle accurately on these headings.

When flying on East or West increase the speed of the aeroplane by increasing power or lowering the nose. Point out that the compass shows an apparent turn towards the South. Demonstrate that if speed is decreased by reducing power or raising the nose the compass will indicate an apparent turn to the North although the actual heading of the aeroplane has not changed. Emphasize that this indicates the necessity of maintaining a steady airspeed, especially when relying on the magnetic compass for direction information.

Guidelines for remembering whether to overshoot or undershoot a particular heading in the Southern Hemisphere are:

- The compass is: **Nippy on North Sluggish on South** or
- **Overshoot North Undershoot South (ONUS)**



TIMED TURNS

Compass turns form part of the training sequence because directional gyros can fail. Also a small minority of light aeroplanes are not fitted with a directional gyro. Given the complexity of compass turns, as indicated above, it is sometimes easier to conduct timed turns i.e. turn at rate one which is three degrees a second. Accordingly, the angular change required is divided by three and the rate one turn is flown for those amount of seconds. This procedure is specially recommended in turbulent conditions.

COMMON FAULTS

The necessity for a good lookout before entering and during all types of turns will have to be continually stressed. Students frequently sacrifice lookout in a bid for greater accuracy.

Faulty turns often result from inaccurate flying and trimming just before entering the turns.

Students may tend to use excessive rudder during turns.

In carrying out steep turns students often fail to realize that the use of the elevator to control height also causes the turn to tighten. It is important, therefore, to point out that during a steep turn it is advisable to reduce the angle of bank before attempting to raise the nose to its correct position, should it have been allowed to sink well below the required position.

For students that are having difficulty with turning it can help to have them roll from a turn in one direction (as soon as the desired bank angle is obtained) to a turn in the other direction.

Gaining height (especially in steep turns) is sometimes due to applying 'back stick' too early. Similarly, losing height (especially in steep turns) may be due to excessive bank angles or failing to apply sufficient back pressure on entering the turn.



09 STALLING

AIM

To teach the student the feel and behaviour of the aeroplane at low speeds, the symptoms of the stall and how to recover with the minimum loss of height.

INSTRUCTIONAL GUIDE

It should be emphasized that an inadvertent stall should never occur. The student must become proficient at recognizing the approach to the stall and taking immediate action to prevent it occurring.

Although the student must be taught some method of entering the stall, it is emphasized that the method of entry is only incidental to the important task of recognizing the warnings of the impending stall and the recovery from the developed stall.

Even if the particular aeroplane normally does not 'drop a wing' during the stall the correct stall recovery technique should be taught from the start.

The first demonstration of a stall should show the student that it is not in any way a frightening experience and should rid the pupil of any false ideas of danger and violent sensations. The first stall is best done at the end of the lesson preceding that on which stalling is to be dealt with in detail. Whilst no real instruction should be given during this demonstration, it is advisable to indicate the point of stall and the commencement of recovery.

Obviously all the points raised cannot be taught during one flight but must be spread over several. Especially in the early stages watch for symptoms of air sickness and discontinue the exercise if necessary.

Before carrying out any advanced stalling exercise it is important that sufficient height is gained to ensure recovery by 3,000 feet above ground level and that the aeroplane is in the appropriate training area. The pre-stalling check will of course vary from aeroplane to aeroplane, but will normally cover such items as harness, hatches, loose articles, trims, brakes, mixture, carburettor heat, fuel, etc. The student should be provided with and expected to learn such a check list. A turn through 360 degrees to ensure that all is clear around and below

should be carried out immediately prior to commencing the first stall and a 90 degree turn should be carried out before subsequent stalls.

PRE-FLIGHT BRIEFING CONSIDERATIONS

AIRFLOW AT THE CRITICAL ANGLE

Explain and illustrate how airflow around an aerofoil varies with increasing angle of attack. Show that lift increases until the critical angle is reached. Figure 9-1 may assist with this explanation. Smooth airflow then becomes turbulent and lift is decreased. This is the stalling angle.

Show that as soon as the angle of attack is decreased below the critical angle the airflow becomes smooth again. Explain that of all the factors affecting lift the pilot can only effectively control the airspeed, angle of attack and aerofoil shape (by use of flap).

Emphasize that the critical angle may be reached at any airspeed and at any attitude.

Explain the movement of the centre of pressure.

Figure 9-1: The relationship between the coefficient of lift and the stalling angle.

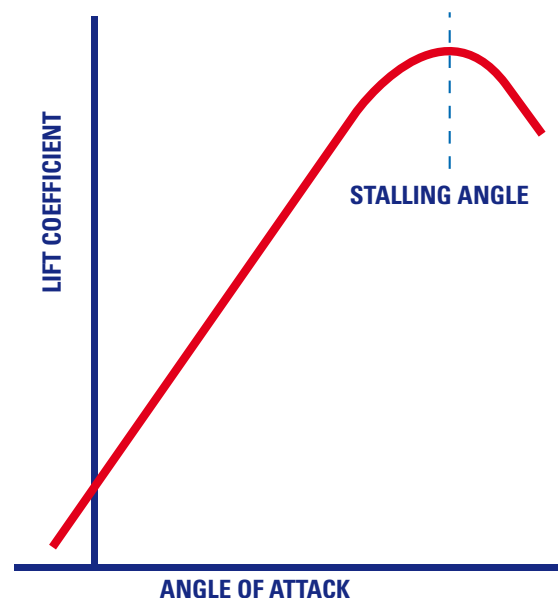



RELATIONSHIP BETWEEN CRITICAL ANGLE AND STALLING SPEED

Explain that for a given weight at '1' g every angle of attack including the critical angle, has its associated indicated airspeed. As the angle of attack of the wings invariably cannot be observed, reference is therefore made to an aeroplane's stalling speed.

FACTORS AFFECTING THE STALLING SPEED

The basic stalling speed of an aeroplane, such as referred to in an Operations Manual or Owner's Handbook means the indicated airspeed at which the aeroplane will stall from straight and level flight, with power off.

Explain that the stalling speed will vary, depending on:

- (a) Weight
- (b) Power
- (c) Flap and/or Slat position
- (d) Manoeuvre
- (e) Ice on or damage to wings

Explain what happens if a wing drops at the stall - auto-rotation - use of ailerons may exacerbate the problem.

CONTROL EFFECTIVENESS

Refer the student back to the exercise on operation of controls. Revise the lesson in terms of decreased control effectiveness at decreasing speed. Emphasize this point making it clear to the student that later on in the take-off and particularly the landing phase the feel, use and effectiveness of the controls will be similar to these factors in the approach to the stall phase.

STALL WARNING

Brief the student on the type of stall warning applicable to the particular aeroplane. The warning may be in the form of juddering, stall warning horn, etc. Where a stall warning horn or similar device is fitted the student should be advised that he or she will be expected to recognize the approach and onset of the stall with and without (if possible) the aid of this device.

APPLICATION IN FLIGHT

Brief the student on the way you intend to demonstrate the stall. Explain the sequence of events:

- pre-stalling checks and lookout
- decrease in power, maintenance of direction with rudder
- nose position with elevator
- Wings level with aileron

Ensure that the student is aware of the approximate attitude to use, decreasing speed, stall behavior of aeroplane at the stall and height loss.

RECOVERY WITHOUT POWER

Control column forward to un-stall the wings. As the speed increases ease out of the dive.

Emphasize that if a wing drops, rudder is used to prevent yaw into the direction of the lowered wing. The wing is raised with aileron when it is un-stalled.

RECOVERY WITH POWER

Brief the student that the recovery using power is similar to that when no power is used with the addition that full power is applied at the commencement of recovery. Point out that you will be demonstrating that use of power results in recovery being made with a much decreased height loss compared with the recovery without use of power.

It is important to stress that power, if used too late, i.e. when the nose of the aeroplane has dropped below the horizon, will result in an increased loss of height. Stress that the recovery using power is the normal method of recovering from a stalled condition of flight.

EFFECT OF POWER AND FLAP

Brief the student on the effect of using power and flap on the stalling speed and characteristics of the particular aeroplane. These factors should be dealt with individually and then collectively, with particular reference to the landing configuration.



EFFECT OF DYNAMIC LOADING

Brief the student in the manner in which you intend to demonstrate that an increased dynamic loading will result in a increase in stalling speed. This is done in three phases, the first being performed with the aeroplane in the take-off configuration whilst executing a climbing turn raising the nose until the stall occurs. To recover, decrease the angle of attack immediately and level the wings. Emphasize that the stalling speed will be higher in the turn than in a straight climb in the take-off configuration.

The second phase is carried out with the aeroplane in the landing configuration whilst executing a gliding turn during which it is stalled. Recover to straight and level flight. Emphasize that the stalling speed will be higher than when carrying out a wings level glide in this configuration.

The third phase is demonstrated with the aeroplane in cruising configuration, a steep turn is commenced with no power increase. The stall is induced and shown to occur at a higher speed than in normal cruising flight.

AIRMANSHIP

An unintentional stall should never occur.

When intentional stalls are practiced, a pre-stalling check must always be carried out and a good lookout maintained during the whole exercise.

During the approach to, and particularly the recovery from stalls, the controls should not be moved harshly as the structural limitations of some aeroplanes can be approached and even exceeded.

Similar to the above, be careful not to exceed the flap limiting speed if they are extended

During solo operations recovery from practice stalls should be completed above 3,000FT AGL.

AIR EXERCISE

- (a) Symptoms of the stall
- (b) Effect of power on recovery
- (c) Recovery when the wing drops
- (d) Effect of power
- (e) Effect of flap
- (f) Recovery from the incipient stall
- (g) Effect of dynamic loading

SYMPTOMS OF THE STALL

Demonstrate a stall from straight and level flight and point out the symptoms.

Close the throttle, prevent yaw with rudder and maintain height with elevator control. Point out the decreasing airspeed, decreasing control effectiveness and stall warning either aerodynamic or mechanical. At the onset of the stall point out the sink, that the nose may drop and, if applicable, that a wing drops.

Recover and allow the student to stall the aeroplane and recover from the stall.

EFFECT OF POWER ON RECOVERY

From straight and level flight close throttle, prevent yaw, maintain height. Point out the symptoms as before and at the point of stall note speed and height. Recover by easing the control column forward, gain speed, ease out of the dive, level off and apply power. Note the height lost. Allow the student to practice.

Next, stall the aeroplane as before but at the point of stall simultaneously apply full power and move the control column forward to un-stall the wings. Regain control, ease out of the dive and level off. Point out that a smaller forward movement of the control column is necessary to regain control and that considerably less height is lost.

RECOVERY WHEN THE WING DROPS

Use the standard recovery, i.e. simultaneous use of power and forward movement of the control column. In addition rudder must be used to prevent the nose of the aeroplane yawing into the direction of the lowered wing. The ailerons should be held neutral until control is regained, when the wings should be levelled.

EFFECT OF POWER

Choose a power setting applicable to the type, usually less than cruise power, and demonstrate the effect of this power on the stall. Point out that the speed reduces slowly, that there is often a shorter duration of stall warning. The stalling speed is lower, the stall may be more marked and the tendency to drop a wing may be more pronounced. Use the standard recovery, pointing out that there is normally a quick recovery with a small height loss.



EFFECT OF FLAP

Demonstrate stalls with various flap settings showing that the speed reduces rapidly and there is often a shorter duration of stall warning. The stalling speed is lower and the stall may be more marked with a tendency to drop a wing. Use a standard recovery with power, raising the flaps in stages.

RECOVERY FROM THE INCIPIENT STALL

Demonstrate the recovery at the stage where warning of the onset of the stall is apparent and that there will normally be no height loss. Demonstrations should be given with various flap and power settings, especially emphasizing the approach configuration. Emphasize that this exercise is one of the most important in the whole of the stalling exercise - stress the danger of stalling on the approach to land.

EFFECT OF DYNAMIC LOADING

Demonstrate the stall with the aeroplane in the take-off configuration. Commence a climbing turn at approximately take-off speed, then raise the nose and increase the rate of turn until the stall occurs. Point out that the stalling speed is higher in the turn than in a straight climb using the same configuration. Use a standard recovery.

Demonstrate a gliding turn with the aeroplane in the approach configuration then gradually raise the nose whilst maintaining the rate of turn, until the stall occurs. Where the aeroplane type is such that the stall cannot be induced with a gentle increase in elevator deflection, increase the elevator deflection to such an extent that the symptoms of the approaching stall are generated. Point out that the stalling speed is higher than in a straight glide. Use standard recovery technique.

Demonstrate a steep turn with the aeroplane in cruise configuration, do not increase power but stall the aeroplane with a positive backward movement of the control column. Point out that the stalling speed is much higher than in normal level flight. Show that recovery is normally immediate on releasing the back pressure on the control column.

COMMON FAULTS

When a wing drops at the stall the student instinctively tries to correct this with aileron. The use of ailerons at the point of stall must be carefully explained to the student. Even if the use of ailerons at the stall is permitted in the type of aeroplane in use the student must understand that in some types of aeroplanes the use of ailerons will aggravate the situation.

During a standard recovery a student is often hesitant or too slow in applying power. It must be stressed that the amount of height lost and the rapidity with which control is regained both depend on the prompt use of high power.

Students sometimes tend to be too harsh in moving the control column back when recovering from the dive, resulting in a high speed stall. There is also a tendency to push the control column too far forward during recovery. This results in too great a loss of height.

Other students may be reluctant to move the control column sufficiently forward in the recovery, possibly because they are uncomfortable with a nose low sight picture.



10 SIDESLIPPING

AIM

To teach the student how to sideslip an aeroplane.

INSTRUCTIONAL GUIDE

Sideslipping is still taught as some aeroplanes are not equipped with flap and the manoeuvre can be used if there is a flap failure or engine fire.

Aeroplanes fitted with flaps are normally not side slipped with flap extended except in an emergency. When sideslipping is taught in such aeroplanes these manoeuvres should be demonstrated and practiced with the flaps retracted.

Whilst the student is learning how to use the controls during a sideslip the manoeuvre should be practiced at height.

The student should be shown and convinced of the effect of sideslipping on the relationship between heading and track. This can be done by sideslipping along a railway track, straight road or some similar feature on the ground.

PRE-FLIGHT BRIEFING CONSIDERATIONS

A sideslip is a manoeuvre in which the aeroplane is in a banked attitude with the natural tendency to yaw reduced or prevented.

Explain that a sideslip is not a normal condition of flight. The lateral stability of the aeroplane tends to reduce the angle of bank; the ailerons must therefore be used to maintain the desired angle of bank. The directional stability tends to turn the aeroplane into the direction of the slip (refer the student back to the further effect of aileron). The rudder is used to prevent or reduce this tendency. The ailerons are usually effective for their purpose but on many aeroplanes the rudder is unable to counteract the weathercock stability even at small angles of bank. The limiting factor in a sideslip is therefore usually rudder.

APPLICATION IN FLIGHT

The practical applications of the sideslip are:

- (a) sideslip into wind; and
- (b) slipping turn

Brief the student on the method of use of the controls in each of the sideslips you intend to teach. Demonstrate the method of entry - bank with aileron - rudder to prevent yaw - elevators to maintain speed. Stress that during the recovery airspeed must be maintained. Also point out that plenty of height is necessary to ensure safe recovery due to the inertia of the aeroplane.

AIRMANSHIP

As always a good lookout must be maintained.

A safe airspeed must be maintained during the whole manoeuvre and especially during the recovery. Flight manual limitations and/or pilot operating handbook recommendations on sideslipping must be complied with.

Ensure the student is aware of the possibility of fuel starvation in a prolonged sideslip with a low fuel quantity and the 'low wing' fuel tank selected.

AIR EXERCISE

- (a) Effect of controls during a sideslip
- (b) Sideslipping into wind
- (c) Slipping turn



EFFECT OF CONTROLS DURING A SIDESLIP

Bank the aeroplane and apply opposite rudder to counteract the tendency to yaw and to control the direction of descent.

Keep the bank constant and maintain the correct nose position, and thus speed, by use of the elevators. Adjust the rudder pressure as necessary to maintain direction.

Point out to the student the instrument indications, especially the state of unbalance and the rate of descent.

To obtain a greater rate of descent, increase the angle of bank. Notice that more rudder is needed to overcome the tendency to yaw. A limit is reached when full top rudder is applied and if the bank is further increased the nose of the aeroplane will yaw towards the lower wing. To recover, level the wings with aileron, control the yaw with rudder, use the control column to maintain the correct gliding speed.

When the student is competent at performing this exercise at altitude carry out the practical applications of the sideslip at low level.

SIDESLIPPING INTO WIND

Choose a line feature, such as a railway line or a road, which is into wind. Put the aeroplane into a sideslip so that it tracks parallel to the selected feature, pointing out that the heading of the aeroplane is at an angle to its path over the ground and that any change in the angle of bank or the amount of rudder being used will produce a flight path which is not parallel to the line feature. Recover as before.

THE SLIPPING TURN

Put the aeroplane into the glide on the base leg of a simulated or actual circuit and roll into a gliding turn. Apply sufficient opposite rudder to cause a slip, controlling the angle of bank with the ailerons and the speed with the elevators and turn until lined up with the selected landing path.

Demonstrate that a slipping turn may also be commenced by banking and sideslipping the aeroplane then controlling the rate of turn with rudder and elevators.

Recovery from the slipping turn is as from a gliding turn but even more height must be allowed for recovery owing to the rate of descent normally being higher than in a straight sideslip.

COMMON FAULTS

Students often apply too much rudder for the angle of bank utilized. Explain that only sufficient rudder should be used in relation to the angle of bank.

Since a common tendency is to lose speed during the recovery, emphasize the need to monitor the IAS during the recovery.



11 TAKE-OFF

AIM

To teach the student how to conduct take-offs under various wind conditions and runway types.

INSTRUCTIONAL GUIDE

Things happen quickly during a take-off, the instructor therefore has to speak sparingly. It is essential that the instructor fully explains what is required before undertaking the air exercise.

Often the students's greatest difficulty is keeping straight from the commencement of the take-off run. until the rudder becomes effective. See that the student releases the brakes properly, straightens the nose wheel before opening the throttle smoothly to take-off power.

If the difficulty in keeping straight persists, the instructor should give the student only the rudder to operate then open the throttle very gradually so lengthening the take-off run. The instructor should then allow the student to operate the rudder and throttle together, then if necessary the control column only, and finally all the controls.

Insist that the student carries out all checks and vital actions conscientiously and ensure that such checks never become a mere formality.

The position in which to hold in order to carry out engine checks and vital actions may vary with local requirements.

If the taxiway layout permits the normal procedure is to stop the aeroplane facing the circuit, thus, in the case of a left hand circuit the intended take-off path will be on the right. This gives the pilot a view of the take-off path, the whole circuit and the approach path. It also shows other pilots that the aeroplane standing in such a position is not yet ready to take-off. In strong winds it is advisable to stop with the aeroplane facing into wind.

When engine failure after take-off is demonstrated the instructor should ensure that the terrain ahead and the conditions and method employed are such that the demonstration will inspire confidence and not the reverse.

PRE-FLIGHT BRIEFING CONSIDERATIONS

TAKE-OFF INTO WIND

It is usual to take-off into the wind for the following reasons:

- (i) It gives the shortest run and lowest ground speed at the moment of take-off
- (ii) There is no tendency to drift and so strain the undercarriage
- (iii) It gives the best directional control, especially at the beginning of the run
- (iv) It gives better obstacle clearance owing to both the shorter run and the steeper angle of climb
- (v) It normally provides the best possible landing area in the event of engine failure immediately after take-off

Explain the reasons for the tendency to yaw during take-off. Two of the causes, slipstream effect (Figure 11-1) and torque reaction (Figure 11-2), affect most aeroplanes. The other two causes, gyroscopic action and asymmetric propeller thrust, affect only those aeroplanes which are fitted with a tail wheel undercarriage.

Figure 11-1: Airflow from propeller corkscrews – impacting on the left hand side of the fin and rudder.

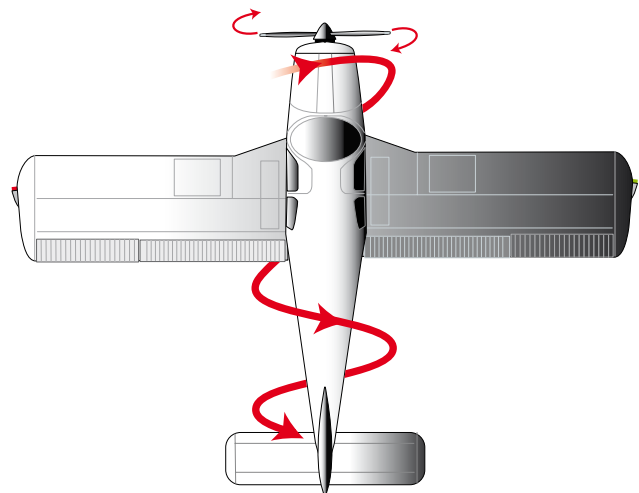
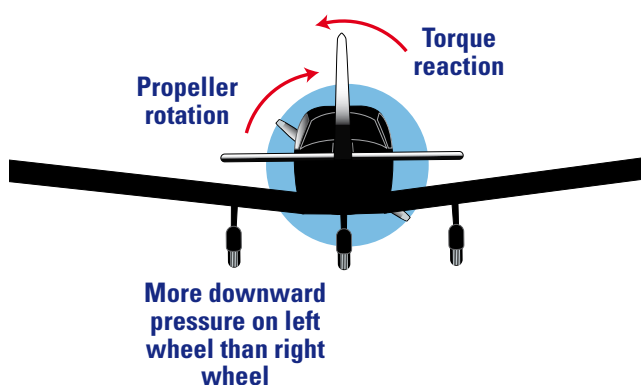



Figure 11-2: Torque reaction is in the opposite direction to propeller rotation.



Explain the factors which affect the length of a take-off run:

- (i) **Weight** The greater the load carried by a given aeroplane the longer will be the run required. This is due to the higher speed required to give sufficient lift and the slower acceleration at high weight.
- (ii) **Wind Strength** The stronger the headwind component the shorter the take-off run.
- (iii) **Surface** If the surface is rough or soft it will have a greater retarding effect than a smooth hard surface.
- (iv) **Temperature** An increase in temperature gives lower air density and may reduce engine efficiency.
- (v) **Airfield Height** The considerations are the same as for an increase in temperature.
- (vi) **Flaps** Lowering the flaps enables the wing to produce sufficient lift for take-off at a lower speed, a shorter run is therefore achieved. A flap setting greater than the optimum should not be used as the added drag may have a detrimental effect. The use of flap is particularly applicable to the short field take-off.

APPLICATION IN FLIGHT

Brief the student on the sequence of actions leading up to the take-off, the method of taking off, and actions during and method of carrying out the climb out. Ensure the student is aware of:

- (i) The method of determining wind direction and the runway in use

- (ii) The position in which to hold whilst carrying out checks immediately prior to take-off
- (iii) The drill of vital actions applicable to the type of aeroplane
- (iv) The use of controls during take-off, especially in keeping straight
- (v) The actions to be carried out after take-off and during climb out

ENGINE FAILURE AFTER TAKE-OFF

Brief the student on the actions to be taken in the event of an engine failure after take-off. The following points must be covered:

- (a) maintain control of the aeroplane
- (b) the speed of action
- (c) the gliding speed
- (d) the choice of landing area
- (e) the height available
- (f) the use of flap; and
- (g) the position of fuel cock, ignition switches, master switch and hatches.

Choice of landing area and height available must be considered together. The amount of turn should be restricted to the minimum dictated by obstacles ahead. It must be stressed that the rate of descent and stalling speed will increase in any turn.

Figure 11-3 shows the usual areas to select for a landing. In any case the intention should be to have the wings level by no lower than about 200FT AGL.

The instructor should also take this opportunity to discuss symptoms and available options for a partial power loss. This is potentially a more complex problem than a simple complete power loss, particularly if the power loss is intermittent. As a minimum, the instructor should discuss the option of closing the throttle to convert the emergency to a complete loss of power and should emphasise the need to resist the desire to turn the aeroplane steeply near the ground in an attempt to return to the airfield. This should be reinforced at regular intervals during the students training.



Figure 11-3: Landing area selection following an engine failure after take-off.

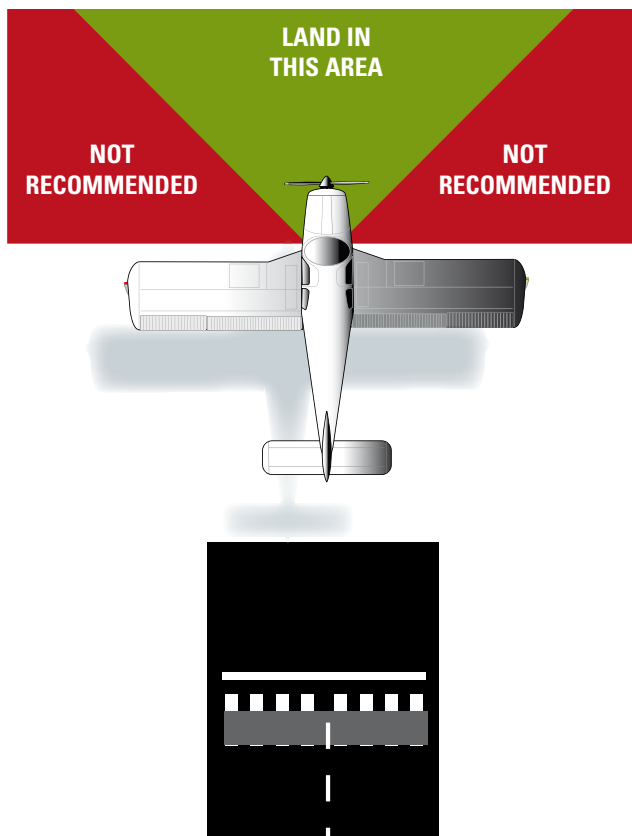

AIRMANSHIP

Impress upon the student the need to keep in mind the wind speed and direction, take-off and circuit direction. When holding prior to take-off the student must choose a position in relation to other aeroplanes so that slipstream is not a hindrance and there is no danger of running into them. Stress the importance of the vital actions and a good lookout to ensure that all is clear. It is important that when cleared for take-off this should be done with a minimum of delay.

CROSS WIND TAKE-OFF

Explain that a cross wind take-off may be necessary when the best take-off run is at an angle to the wind. More particularly runway directions dictate that many take-offs must be made out of wind.

Explain that when an aeroplane runs along the ground out of wind the following factors must be taken into consideration:

- (i) The wind on the keel surface tends to turn the aeroplane into wind
- (ii) The aeroplane tends to drift and so imposes a side strain on the undercarriage
- (iii) The wind tends to lift the wing on the windward side.

Explain how to assess the value of the cross wind component. This can be done using simple trigonometry or with the aid of a navigation computer. A simple 'rule of thumb' method is to assess the number of degrees out of wind then use the following figures. If the take-off path is 20 degrees out of wind the cross wind component measured at right angles to the take-off path is approximately one-third of the wind strength. Other figures are:

30°—half wind strength.

45°—almost three-quarters wind strength.

60°—almost nine-tenths wind strength.

Ensure that the student is aware of the maximum cross wind component for the type of aeroplane or the maximum component to which student pilots are allowed to operate, if this is applicable.

APPLICATION IN FLIGHT

The briefing should take a form similar to that for a normal into wind take-off except that the student must be made aware of the need to prevent the weathercock tendency. Emphasize the necessity to hold the aeroplane on the ground until a higher than normal take-off speed has been attained and then lift off cleanly. Demonstrate how to correct for drift after take-off.

ENGINE FAILURE AFTER TAKE-OFF

The same considerations as for an into wind take-off apply, except that it may be advantageous to make a turn into wind providing sufficient height is available.

AIRMANSHIP

The same considerations apply as with an into wind take-off with perhaps even more emphasis on lookout.

SHORT FIELD TAKE-OFF*

* This expression is a misnomer as the performance charts indicate if the runway is suitable for your intended operation. However, if a runway is only just suitable for your intended operation, then a short field take-off technique is applicable.



Explain that the short field take-off technique is useful when taking off from a field of marginal length. It is also of value when using soft or rough surfaces.

As the student progresses explain the use of take-off performance charts.

APPLICATION IN FLIGHT

Brief the student on the technique for the particular aeroplane with particular reference to the use of power, flaps and elevators. The student must also be aware of the lift-off speed and actions on the subsequent climb out.

A maximum angle climb is normally entered after take-off and held until the actual or assumed obstructions are cleared.

ENGINE FAILURE AFTER TAKE-OFF

The same considerations apply as for a normal into wind take-off except that it is even more essential to assume the gliding attitude very quickly owing to the lower climbing speed.

AIRMANSHIP

All the available take-off length should be utilized.

The use of high power whilst the aeroplane is stationary should be avoided when loose stones, gravel, etc., are present. This particularly applies to aeroplanes fitted with nose wheels, as considerable propeller damage may result.

AIR EXERCISE

- (a) Take-off into wind
- (b) Cross wind take-off
- (c) Short field take-off

TAKE-OFF INTO WIND

Point out the take-off and circuit direction, the taxi path to the holding point and position in which to hold to carry out the necessary checks and vital actions prior to takeoff. Make this procedure the student's responsibility as soon as possible.

Complete the checks according to the check list, ensure that all is clear and obtain a take-off clearance if necessary.

Line up without delay, ensuring that the nose wheel is straight. Point out a reference point on which to keep straight - remember the offset seating effect if applicable

- then smoothly apply take-off power, keeping straight with rudder. During the ground roll it is essential to check that the airspeed is showing an increase, the RPM is as expected and the engine oil pressure (and fuel pressure if applicable) is normal. As the aeroplane gathers speed ease it into the flying attitude. In nose wheel aeroplanes this means raising the nose until either the weight is off the nose wheel or the nose wheel is just clear of the ground.

Maintain this attitude by a progressive backward movement of the control column and when flying speed has been obtained the aeroplane will become airborne.

After becoming airborne gradually assume the climbing attitude and at a safe height complete any after take-off checks and carry out a normal climb.

If flaps are used for take-off, point out the dangers of raising them too early.

Demonstrate simulated engine failure after take-off from about 500 feet. Point out that it is essential to assume the gliding attitude and speed very quickly. Choose a landing area ahead keeping alteration of heading to a minimum – see Figure 11-3. Change fuel tanks quickly if possible. Use flaps or sideslip as necessary. If changing fuel tanks has had no effect, turn off the fuel, ignition and master switch before impact. In most aeroplanes it may be advisable to unlock doors or hatches if time permits.

CROSS WIND TAKE-OFF

Demonstrate that the take-off technique to be used in a cross wind is very similar to that used for a normal take-off. However, it may be necessary to make more positive use of the rudder to prevent the aeroplane yawing into wind. In addition the aeroplane is held firmly on the ground by a forward movement of the control column until flying speed has been attained, then it is flown off cleanly and positively by a backward movement of the control column. Once well clear of the ground turn into the wind to counteract drift so that the track is a continuation of the take-off path. Climb in the usual way. On most aeroplanes it is recommended to have 'the ailerons into wind' during the take-off run. With this technique the pilot must be prepared for the ailerons to suddenly take effect.

Demonstrate that should engine failure occur after take-off the actions are the same as for the into wind case except that it may be advantageous to turn into wind if height permits.



SHORT FIELD TAKE-OFF

When completing the vital actions before take-off lower the flaps to the optimum lift setting.

Line up on the selected take-off path making use of all the available space.

Apply the brakes and open the throttle to the maximum power setting at which the brakes will hold, then release the brakes and continue to open the throttle to full power if not already applied.

Gain the flying attitude as soon as the elevators are effective then ease back on the control column so that the aeroplane becomes airborne as early as possible.

Point out the short take-off run to the student.

When airborne establish a climb using take-off power and the speed which gives the maximum angle of climb.

When the obstacles (actual or simulated) are cleared resume a normal climb, raising flaps when it is safe to do so.

When practicing this exercise on a surface where loose stones and gravel are present, point out that the take-off run is only slightly increased if power is applied whilst rolling forward slowly rather than while stationary against the brakes, when serious damage may result from stones being thrown up into the propeller.

Demonstrate that should engine failure occur during the maximum angle climb a very positive forward movement of the control column is essential if control of the aeroplane is to be maintained.

COMMON FAULTS

Over controlling and lack of co-ordination are usually caused by muscular tenseness (demonstrated by too firm a grip on the control column) brought about by the high degree of concentration required in the initial attempts. Encourage the student to relax as much as possible and that will only be achieved if the instructor appears to be relaxed.

Difficulties in this sequence (and the following sequence) may be the result of rushing the earlier sequences and introducing circuit training too early.



12

APPROACH AND LANDING

AIM

To teach the student to land safely under various wind and runway conditions.

INSTRUCTIONAL GUIDE

Before the first solo flight the student must be able to make competent engine assisted approaches and landings and be able to go around again safely. Glide approaches and landings must also have been practiced sufficiently for the student to be able to attempt a landing in the event of engine failure and still land if the aeroplane is slightly high on final. The remaining sequences of the Air Exercise should be covered after the first solo.

Many students have difficulty in mastering the approach and landing. This is a matter of judgment and there is no simple way of teaching judgment to those to whom it does not come easily. Proficiency is attained mainly through practice and although the instructor's advice and guidance is of great help in the early stages any attempt to analyze the student's difficulties too specifically should be delayed until he or she has had a fair amount of practice. Until this practice is gained the errors are likely to be of a random nature while the student is becoming accustomed to the appearance and feeling of a good landing. After the student has grasped the basic requirements any errors will normally form a consistent pattern which can be recognized, analysed and corrected.

It is important that the instructor demonstrates quite frequently the type of approach and landing being taught.

Many instructors are reluctant to do this as they feel that they are depriving the student of one more approach and landing. This is not true. Only by seeing and retaining a mental picture of this exercise can the student learn to land the aeroplane.

The completion of the touchdown should be judged by the change in attitude of the aeroplane rather than by movements of the control column. The attitude should be changed by reference to the landing horizon (edge of airfield) and the front of the aeroplane. The idea may be helped if the instructor places the aeroplane in the

approximate position on the airfield where it will be touching down, then shows the student the sight picture that will be seen during the landing. In the case of most nose wheel type aeroplanes the attitude in which it rests on the ground has to be modified slightly and this can be done by visualizing the attitude resulting from the main wheels being on the ground and the nose wheel a few inches above the ground.

During the float or hold off period the instructor should watch the student's eyes to see where he or she is really looking. Students normally tend to look too close. Advise them to look ahead and slightly to the left at a point about 50 to 100 meters away. The student's gaze should not be rigid, this point being the centre of what he can see. If the student looks too far ahead objects will hardly appear to move, if too close they will appear to move too fast and become blurred. Both these conditions make judgment very difficult.

Remember that students will rarely make a good landing unless they make a good approach. Good approaches rarely follow bad circuits. It therefore follows that the instructor should not allow the student to attempt landings until he or she can fly a reasonably accurate circuit and approach.

To do so will, in most cases, only discourage the student when the almost inevitable bad landing follows. It is well to remember that the aim in teaching consistent square circuits is to develop judgment as rapidly as possible by repetition.



PRE-FLIGHT BRIEFING CONSIDERATIONS

THE CIRCUIT

The so called square circuit is used for training purposes and the student must be given a clear briefing on this exercise. The student should be presented with a diagram of the standard circuit pattern and the following points must be emphasized:

After lift off ensure the aeroplane tracks on the extended centre line of the runway

Commence turn onto cross wind at 500FT AGL, or slightly higher in a low powered aeroplanes and allow for drift

- Turn onto the down wind leg in accordance with company policy.
- *Check heading, height, distance out and RPM
- Complete pre landing checks
- *Turn onto base, reduce power, select flap, trim and allow for drift
- Commence turn onto final at about 500FT and select landing flap when rolled out on final

*Explain and demonstrate to the student the correct distance out on down wind' and the base turn position for normal, flapless and glide approaches.

The method of re-entering the circuit should be emphasized though the student will in fact have had practical demonstrations of this during previous exercises. The method used will depend on whether or not aerodrome control, including the use of radio procedures, is in operation.

CIRCUIT

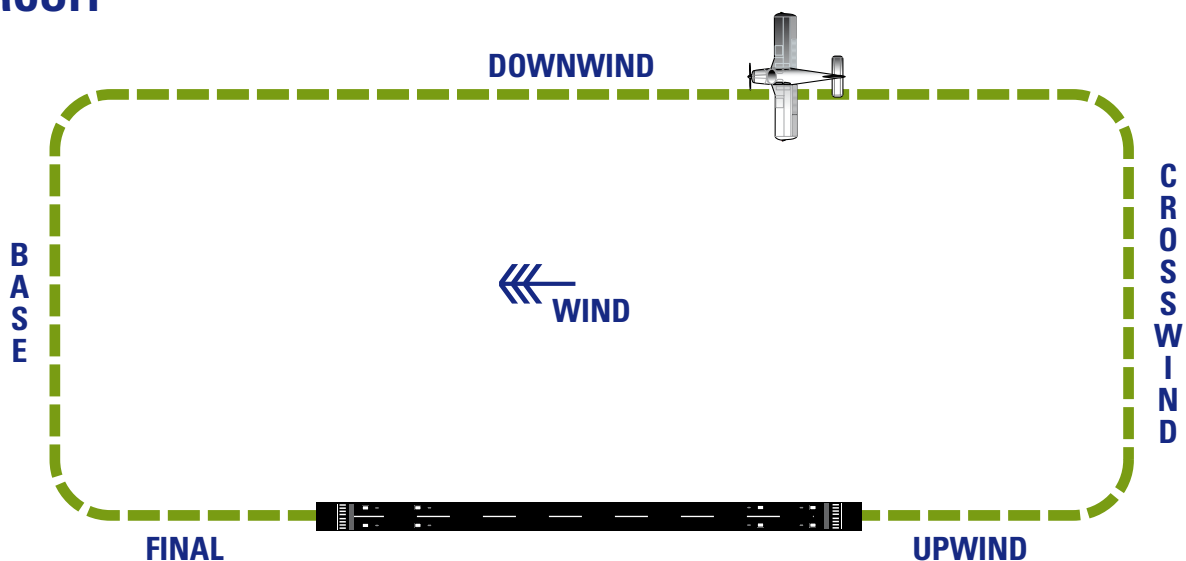



APPROACH INTO WIND

The approach and landing is normally carried out into wind for the following reasons:

- (i) It gives the shortest run and lowest ground speed during the subsequent landing
- (ii) There is no tendency to drift
- (iii) It gives the best directional control during the landing
- (iv) The angle of descent is steeper, thus improving the view of the landing path.

The student should also be briefed on the effect of wind gradient. The effect of a sharp wind gradient on an aeroplane approaching to land is a sudden reduction in IAS. This in turn may cause rapid sink followed by a heavy landing or even failure to reach the runway before striking the ground.

The use of flaps during an approach will give the pilot:

- (i) A steeper path of descent at a given speed and power setting
- (ii) A lower stalling speed, thus permitting an approach at a lower airspeed.

The amount of flap used will depend on the type of aeroplane and the wind conditions prevailing. In strong crosswinds it is generally preferable to use only partial flap in most training aeroplanes. The student must be briefed on this point so that there is no doubt as to the amount of flap to use.

ENGINE ASSISTED APPROACH

This should be taught as the normal procedure to make an approach to land.

The use of power on the approach enables the rate of descent to be adjusted safely over a very wide range. However, the instructor must not allow the student to carry out very low flat approaches using high power.

Other reasons for power assisted approaches are:

- (i) By using selected power settings it is possible to regulate the angle of descent despite varying wind strengths
- (ii) The change of attitude when rounding out is small compared with that for a glide approach
- (iii) The use of power may reduce the stalling speed and thus a lower approach speed can be used

APPLICATION IN FLIGHT

Brief the student on the method of carrying out a powered approach.

Ensure the student is aware of:

- (i) The position in the circuit from which to commence the approach
- (ii) The approach speeds to be used
- (iii) The flap setting to be used
- (iv) The selected approach speed is normally controlled with the elevator and the rate of descent and thus the approach gradient is controlled with the throttle. There is another school of thought who believes it best to teach attitude to control aiming point and power to control IAS. However, the method to be employed, which may be variations of the above, is the decision of the CFI responsible for the operation.

There are a number of views on how to achieve a satisfactory landing, including a mathematical model. However, as stated earlier the teaching technique to be employed is the responsibility of the CFI

GLIDE APPROACH

The main features of the glide approach are:

- (i) As there is no power with which to adjust the rate of descent a high standard of accuracy is required to judge the position on the base leg at which to close the throttle. Development of this aspect of judgment is important for the later emergency exercise simulating complete loss of engine power
- (ii) The rate of descent is high and the angle of descent may be steep
- (iii) A considerable change of attitude is made during the round out. The round out must therefore be started earlier than for an engine assisted approach



APPLICATION IN FLIGHT

Brief the student on the method of carrying out the glide approach. Ensure that he is aware of:

- (i) The position in the circuit from which to commence the approach
- (ii) The approach speeds to be used
- (iii) The flap setting to be used
- (iv) The necessity to maintain the correct speed with the elevator. Brief that should there be any doubt about reaching the runway power should be used early. If the student is overshooting badly the approach should be abandoned.

LANDING

The student should be in no doubt as to the type of landing he or she is to perform.

NORMAL LANDING

The aeroplane is landed on the main wheels with the nose wheel held off the ground. However, the nose wheel is usually held only a small distance off the ground in an attitude which is very little different from that of a normal engine assisted approach. Consequently only a small change of attitude is required when rounding out.

FLAPLESS LANDING

This type of landing may be used in gusty or strong cross wind conditions or in the event of mechanical failure of the flaps.

The descent path may be flatter, making judgment more difficult and an engine assisted approach should be made. An additional advantage in using power is that the lowest safe speed during the flapless approach is obtained with power on. Ensure that the student is aware of this recommended speed. Due to the absence of drag there may be a longer float period.

EFFECT OF CROSS WIND

The initial part of the approach is similar to that of a normal into wind approach and landing, except that the turn on to the final leg has to be started earlier or later than usual, depending on the cross wind direction. There are two recognized methods of making the final approach. They are:

- (i) To counteract the drift by sideslipping the aeroplane into wind (banking into wind) sufficiently to keep the resultant path of descent in line with the intended landing path
- (ii) To counteract the drift by heading slightly into wind keeping the wings level, so that the aeroplane tracks along the intended landing path

The second is the most suitable method for most modern aeroplanes. This method has therefore received greatest emphasis in this manual. The student must have one of these methods carefully explained to him and should become competent at employing this one type before being introduced to the alternative method.

Regardless of the method employed the student must carry out engine assisted approaches under cross wind conditions.

During the final stages of the approach there is normally less drift as the wind speed decreases near the ground. However, this is sometimes offset by the reducing airspeed during hold off. The temptation to align the aeroplane with the intended landing path too soon must be resisted.

Consideration must be given to the amount of flap used in cross wind conditions. In some light aeroplanes it may be best to use no flap at all in a strong cross wind, or the normal landing setting in a light cross wind. Some aeroplane manufacturers give specific advice on the use of flap in these conditions. Instructors must be aware of this and teach their students accordingly.

The student should be briefed to expect that as the speed of the aeroplane decreases during the landing run, the tendency for it to weathercock into wind will increase. Normal steering methods should be employed to keep straight, but students should be made aware of the need to use coarse opposite rudder, with brake if necessary.



SHORT FIELD LANDING*

* This expression is a misnomer as the performance charts indicate if the runway is suitable for your intended operation. However, if a runway is only just suitable for your intended operation, then a short field landing technique is applicable.

The short field landing technique is of great value when the pilot is forced to use a landing area of marginal length or when the pilot is either unfamiliar with or unsure of the condition of the landing surface.

Note: Remind the student that the recommended speed may be lower than for the normal engine assisted approach, and aim to attain this speed as the aeroplane crosses the airfield boundary at the minimum height consistent with obstacle clearance.

As with a normal engine assisted approach the airspeed is normally controlled with the elevators and the rate of descent with the throttle. Because of the low speed the aeroplane will touch down without float, or with minimum float, when the throttle is closed. It may be necessary to increase power momentarily to arrest the rate of descent and to prevent the aeroplane landing heavily. This applies particularly when a strong wind gradient is experienced. Full flap should normally be used.

The already short landing run may be further shortened by the judicious use of brakes.

MISS LANDING AND GO AROUND PROCEDURE

In the early stages the student must be briefed that he or she must not try to convert a bad landing into a good one but must, without hesitation, go around again. Similarly the student must be briefed to go around again if the aeroplane is held off too high.

The following points must be emphasized:

- (i) The application of full throttle or normal take-off power, as applicable
- (ii) The speed for the climb out whilst still in the landing configuration
- (iii) The method of raising flap
- (iv) That large changes of trim may be experienced during this procedure.

As the student progresses he or she must be briefed on and have demonstrated the method of converting a poor but not dangerous landing into a good arrival. This involves the use of power to prevent any high rates of descent

and, in the case of single engine propeller aeroplanes, to increase the effectiveness of the elevator and rudder. The student must be warned that the only way to recover from an extreme attitude or abnormally low airspeed is to apply the full go around procedure.

AIRMANSHIP

The following points of airmanship must be stressed both before flight and during the air exercise:

- (i) The often large number of aeroplanes in the circuit demands a particularly careful lookout
- (ii) Turns in the circuit must be limited to medium angles of bank except in emergency
- (iii) All checks must be carried out thoroughly
- (iv) After landing, the aeroplane must be taxied according to the local regulations but in all instances must give way to other aeroplanes taking off and landing.

AIR EXERCISE

- (a) Engine assisted approach
- (b) Glide approach
- (c) Normal landing
- (d) Flapless landing
- (e) Cross wind landing
- (f) Short field landing
- (g) Go around procedure.

ENGINE ASSISTED APPROACH

This demonstration commences on the down wind leg. Show how to judge the distance from, and how to remain parallel to, the landing path. Carry out the down wind checks. Show the position at which to turn on to base leg.

On base allow for drift. At the appropriate point reduce power and settle at the correct speed for the turn in. Select flaps as required and re-check the landing drills. Turn on to the final leg then set the airspeed as recommended for the final approach. Control the airspeed with the elevator and the rate of descent with the throttle, showing how to adjust the approach path to achieve the required touchdown point. Demonstrate how to carry out the type of landing applicable. Ideally the power should be reduced smoothly whilst the aeroplane is being placed in the landing attitude so that the throttle is closed completely just as the wheels touch the ground.



GLIDE APPROACH

As with the engine assisted approach, commence instruction for this exercise whilst on the down wind leg. Carry out appropriate checks, then turn on to base leg and re-check all landing drills. When within guaranteed gliding distance of the intended landing point, close the throttle, settle at the required gliding speed, set flap and trim.

Demonstrate that by turning either towards or away from the airfield, correction can be made for undershooting or overshooting. When nearly opposite the landing path turn on to the final leg. During basic training a straight descent should then be made from a height of not less than about 400FT.

Keep the flaps at a setting less than the normal landing setting until it becomes obvious that there is surplus height to be lost, and then set them as required. Maintain the correct speed with the elevators.

Demonstrate where to commence the round out, pointing out that the change of attitude is much greater than when carrying out an engine assisted approach.

Make the type of landing applicable to the aeroplane type.

NORMAL LANDING

Approach and round out the aeroplane in the normal manner. Keep the aeroplane flying just above the ground by progressively moving the control column back until the main wheels touch down. At this point continue to move the control column back to prevent the aeroplane pitching forward suddenly. The nose wheel should then be kept off the ground if possible whilst the speed decreases, but it should be lowered to the ground before elevator control is lost. Brakes should not be applied until the nose wheel is firmly on the ground.

FLAPLESS LANDING

After completing the pre-landing checks continue down wind. Turn on to base leg then commence the approach which should invariably be engine assisted.

Maintain the recommended speed which is normally higher than when flaps are used. Point out that there is usually a smaller round out angle and the possibility of a longer float which occurs before the aeroplane touches down. Use the brakes normally and, when the aeroplane has stopped, draw attention to the much longer distance covered.

CROSS WIND LANDING

Demonstrate how the down wind leg is flown allowing for drift in order to track parallel to the landing path.

When turning on to the final leg show how to allow for the different radius of turn due to the cross wind, by turning either early or late according to the direction from which the wind is coming.

During the final approach head the aeroplane sufficiently into wind so that the path of flight is along the intended landing path. Place the aeroplane into the landing attitude, still with this correction for drift applied, then just before touchdown apply rudder smoothly to yaw the aeroplane so that it heads along the landing path. Use the ailerons to keep the aeroplane level whilst applying this rudder.

Another technique is to fly 'wing down into wind' on final, effectively controlling direction with bank angle, touching down on the into-wind wheel first.

A combination of both the above techniques are commonly used.

After landing, the nose wheel should be placed firmly on the ground in order to improve directional control through the nose wheel steering. In all aeroplanes make careful use of the rudder and brakes to prevent the aeroplane from swinging into wind i.e. weather cocking.

SHORT FIELD LANDING

Carry out a normal circuit and after the turn on to final approach lower additional flap as required. Remind the student that full flap should normally be used for this type of approach. Progressively decrease the airspeed, aiming to cross the boundary at the correct airspeed for this type of approach*. Point out that there is very little round out owing to the aeroplane's attitude. Demonstrate that when the aeroplane is near the ground the rate of descent is checked with the elevator, assisted by an increase in power, if necessary. When the aeroplane is at the correct hold off height, close the throttle and land. Point out the absence of significant float.

*In the early stages of training the approach speed should be stable from early final as some students cannot cope with reducing speed approaches i.e. changing approach profiles.

Lower the nose wheel or ensure that the tail wheel is on the ground as applicable and apply brake.



GO AROUND PROCEDURE

This procedure must be demonstrated both in the air before touchdown and after a bad touchdown resulting in a bounce.

When demonstrating the exercise whilst still in the air first apply take-off power. Trim, then hold the aeroplane level until the recommended climbing speed with flaps down is obtained, and then raise the flaps to their optimum setting. At a safe height and speed raise the flaps fully and resume a normal climb.

Demonstrate that after a bad landing or if the aeroplane is held off much too high the procedure is to go around again. In this case care must be taken not to fly back into the ground in a nose down attitude. Unless the POH states otherwise a positive rate of climb or at least level flight must be established before flaps are raised to their optimum setting as quickly as possible on most aeroplanes.

As the student progresses demonstrate that a poor but not dangerous landing may be converted into a good arrival by judicious use of power. However, caution must be exercised when using this technique on relatively short runways as the landing roll can be significantly increased.

COMMON FAULTS

Causes of bad landings include:

- Failure to round out sufficiently. This may be due to the approach being too steep or the student may be getting tense when the ground appears to rush up at him or her
- Beginning to hold off then ceasing to do so. Make sure that the student is looking well forward of the aeroplane and realizes that a backward progressive movement of the control column is necessary right up to the point of touchdown
- Holding off too high consistently. This can often be overcome by demonstration i.e. flying low over the runway at hold off height
- General difficulty with all stages of landing up to the point of touchdown. This may be due to faulty approaches at incorrect speeds and poor use of power. An inadequate view due to the seat position being too low can also cause this
- In giving too much attention to the actual landing after an engine assisted approach the student often fails to

close the throttle in the final stages. This delays the touchdown

- Having touched down successfully a student often has difficulty in controlling direction during the landing run. This may be due to relaxing concentration after touchdown or conversely being too tense and over controlling. Another cause may be that the student has been given too many touch and go landings and lacks practice in controlling the landing run
- Student lining up the cowling parallel to the edge of the runway and touching down with self induced drift
- Student inadvertently applying left aileron when moving the control column aft (poor ergonomics)
- Student moving head during round out (trying to look over the nose) and 'losing' the required sight picture
- Allowing the aeroplane to touch down at too high a speed, often caused by 'relaxing' during the hold off.

GENERAL FAULT

Many students do not understand the relationship between power/attitude and IAS on base and final. This often results in making large power changes late rather than timely minor power adjustments.



13

SPINS AND SPIRALS

AIM

To teach the student how to recognize the onset of a spin or spiral dive and learn how to recover from these conditions of flight.

INSTRUCTIONAL GUIDE

Students often approach this exercise with some apprehension. Instructors should attempt to remove this by explaining that there is no mystery about it, and later by demonstrating how easy it is to recover at any stage of the spin or spiral dive. Even so instructors should spread this exercise over a number of lessons rather than concentrate it in one long one.

Instruction and practice in the fully developed spin is not a mandatory exercise when the student is being taught to fly on most types of aeroplanes. However, whether the full spin is demonstrated or not, and even though a student may have experienced the incipient spin while practicing stalling, they must be given sufficient further instruction in the incipient spin stage in order to be fully familiar with the recognition and prevention of the spin before it develops fully.

The first demonstration of a spin or spiral dive is best done at the end of the lesson preceding that in which the exercise is to be dealt with in detail. Whilst no real instruction should be given during this demonstration the instructor should keep the student informed of what is going on. Talking in a normal relaxed manner during the manoeuvre will help greatly to keep the student relaxed.

During a rapid spin it is not unusual for students to become confused as to its direction. This does not normally happen when the aeroplane is deliberately placed in a spin, but in an unexpected spin impressions gained may be quite erroneous. Similarly many students will be convinced that they are spinning when the aeroplane is actually performing a spiral dive. For these reasons it is imperative that any impressions gained during these manoeuvres should be confirmed by the instruments.

The most important points are the confirmation of the direction of spin by the turn indicator, and confirmation by means of the airspeed indicator as to whether the aeroplane is actually in a spin or a spiral dive.

When the type of aeroplane in use permits spinning, the emphasis should first be placed on the fully developed spin. When the student has mastered the recovery from this condition, the emphasis should be placed on early recognition of the various conditions that can lead to a spin, and the clean recovery at the incipient stage. Deliberate spirals should be done only as a dual exercise. Instructors must ensure that the aeroplane being used for training is suitable for the demonstration of the spiral dive. The main consideration is the structural limitations imposed on the particular type of aeroplane. In this manoeuvre the airspeed builds up so rapidly that it is possible to overstress the aeroplane with poor recovery technique. For these reasons it is imperative that the instructor be completely familiar with the aeroplane's performance in this manoeuvre before attempting to demonstrate it.

When carrying out these exercises it is essential that a check be carried out to ensure that it is safe to do so, i.e. check for traffic below.

The aeroplane must be clear of inhabited areas and normally in an area designated for the practice of such exercises. In addition it should be at a height sufficient to ensure recovery by 3,000FT above ground level. The pre-spinning check will vary from aeroplane to aeroplane but will normally be similar to that used as a pre-stalling check in that particular aeroplane. In most aeroplanes flaps and undercarriage must be retracted during both the spin and spiral. The attitude indicator should be caged (if possible) during spinning, though it is usually preferable to leave it un-caged whilst practicing a spiral dive in order to impress on the student their indications during this manoeuvre. In all cases a 360° turn to ensure that all is clear around and below should be carried out immediately prior to commencing each exercise.



PRE-FLIGHT BRIEFING CONSIDERATIONS

CAUSES OF A SPIN

A spin is a condition of stalled flight in which the aeroplane describes a spiral descent. During a spin it is simultaneously rolling, pitching and yawing, its movement being usually automatic until recovery is initiated by the pilot.

It must be made quite clear to the student that a spin is not a normal condition of flight. The wings are stalled and the aeroplane does not react to the controls in the usual way. The airspeed is relatively low and does not increase until recovery action is initiated. An aeroplane is made to spin, whether accidentally or deliberately, by faulty use of the controls particularly the rudder.

Ensure that the student has absorbed the stalling demonstrations to such an extent that he or she quite clearly understands the forces acting at the stall and particularly autorotation.

DEVELOPMENT OF A SPIN

Brief the student on the development of the spin as applicable to the type of aeroplane being used. Generally aeroplanes do not go directly from the stall into a spin, but there is usually a transition period which may vary considerably from aeroplane to aeroplane. When a wing drops at or near the point of stall the aeroplane's nose begins to yaw towards the lower wing tip, and as the angle of bank increases the nose will drop below the horizon. If no preventative action is taken the nose will continue to drop, sometimes sharply, the rate of rotation will increase and the spin will develop fully.

CHARACTERISTICS OF A SPIN

The student should be briefed on what to expect from the particular aeroplane during the spin. Generally there is a steep attitude, autorotation is maintained continuously, buffeting is usually evident and the airspeed remains almost constant at a low figure. The aeroplane may pitch regularly. If it does, the rate of rotation normally decreases as the nose comes up in relation to the horizon and increases as the nose sinks.

The effect of the position of the Centre of Gravity (CG) must be pointed out to the student if movement of this position within the limits laid down has a great effect on the spinning characteristics of the aeroplane. Normally a forward CG results in a steeper spin with a high rate of descent. A forward CG makes recovery much easier and may even prevent a spin altogether, resulting in a spiral dive. An aft CG tends to flatten the attitude resulting in a lower rate of descent. The recovery action to be taken when an aeroplane is spinning in a flat attitude is the same as the normal recovery technique with respect to the actual control movements. However, in the flat spin case it is essential to ensure that full control movement is applied in the recovery action and that this is maintained if necessary, for a much longer period than normal. In some aeroplanes it takes many turns to recover from a flat spin.

APPLICATION IN FLIGHT

Brief the student on the manner in which you intend to demonstrate the spin and recovery. Explain the sequence of events e.g. pre-spinning check, approach to stall, use of controls to initiate spin and during spin and actions to recover from the spin.

Ensure that the student understands that once the aeroplane has entered the spin, recovery involves very positive use of the controls. The rudder is applied to its full extent to reduce yaw and after a brief pause the elevator is moved forward progressively until the spin stops. Full rudder must be maintained throughout the process of recovery. The increase in rotation speed is an indicator that the recovery process is working. The rudder must be centralized promptly as soon as the spinning stops and wings levelled with aileron, then easing gently out of the resulting dive. The student must be told that if a spin is entered with power on, the throttle must be closed immediately. Power should not be increased until a recovery has been effected and the nose of the aeroplane is at least level with the horizon.



It is important to emphasize that sufficient time must be allowed for the recovery action to take effect and this is particularly important where the spin has become flat. Aeroplanes which are difficult to recover from a spin are not used for civil flying training, and therefore a student should not be worried at an early stage by being briefed on the actions to be used if the aeroplane continues to spin in spite of normal recovery action. However, when the student is quite confident in spin recoveries, brief on these emergency recovery procedures. The student must understand that to recover from a spin the yaw must be reduced and the aeroplane somehow placed into a steep nose-down attitude. In all cases full opposite rudder must be maintained whilst carrying out the following supplementary action:

- (i) Pull the control column fully back, hold it there for five seconds then push it fully forward
- (ii) Push the control column sharply forward, pause a second, fully back, pause a second then fully forward and so on. When power is available the throttle should be opened as the control column is moved forward and closed as it is moved back. The object is to induce a rocking motion until a steep nose-down attitude, which will un-stall the wings, has been achieved
- (iii) The effect of the ailerons will vary between aeroplanes. Putting the control column (or control wheel) in the forward corner (i.e. in-spin aileron) opposite to the rudder will probably have the best effect
- (iv) As a last resort lower flaps.

RECOVERY AT THE INCIPIENT SPIN STAGE

Brief the student that you will be demonstrating the entry to the spin in the normal manner. Point out that before the spin develops fully you will be recovering by ensuring the throttle is closed and the controls are centralised followed by recovery from the ensuing unusual attitude.

CAUSES OF A SPIRAL DIVE

A spiral dive is a condition of flight during which the aeroplane is performing a steep turn with an excessive nose-down attitude coupled with a very rapid build up in airspeed. Any attempt to reduce speed by raising the nose with the elevators will only result in tightening and aggravating the spiral, causing excessive loading on both the airframe and pilot.

The spiral dive is frequently caused by a poorly executed spin entry. For this reason it is imperative that the differences between the spin and spiral be emphasized. Another common cause of the spiral dive is that during the early attempts at instrument flying the student frequently fails to maintain a turn or directional control within safe limits.

For this reason the student must be thoroughly briefed on the instrument indications to be anticipated during the exercise.

APPLICATION IN FLIGHT

Brief the student on the technique you will be using to enter the spiral dive and the use of the controls during the recovery. Emphasize that prompt recognition of the condition is essential as the speed will build up very rapidly and will, if not checked, exceed the maximum permissible.

AIRMANSHIP

An unintentional spin or spiral dive should never occur. When intentional spins or spirals are practiced, a safety check should always be carried out and a good lookout maintained during the whole exercise.

During these manoeuvres great care must be exercised in the use of controls. No harsh movements should be made, especially when high speeds are involved, as the structural limitations of some aeroplanes.

Prior to flight it is essential to check that the student can input full rudder and elevator travel with the safety harness fully tightened.



AIR EXERCISE

- (a) The student's first spin
- (b) Spin from level flight and recovery
- (c) Recovery from the incipient stage
- (d) Spins from descending turns
- (e) Recovery from spiral dive

THE STUDENT'S FIRST SPIN

Carry out the pre-spinning checks, allowing the student to participate. Prior to the actual entry remind the student that in this particular aeroplane type the spin is just another condition of flight. Make the entry as smooth as possible and do not allow the aeroplane to rotate for more than two complete turns. Whilst not giving any specific instruction, point out the direction of rotation in the spin and subsequently the ease of recovery.

SPIN FROM LEVEL FLIGHT AND RECOVERY

Carry out the checks before spinning. Demonstrate the spin in both directions with the engine idling. Commence the manoeuvre as for a practice stall but just before the point of stall smoothly apply full rudder in the direction in which it is desired to spin, simultaneously moving the control column fully back. During the spin hold on full rudder and keep the control fully back. Point out the attitude, the direction of rotation and the indications of the instruments, particularly the turn indicator, airspeed indicator and altimeter.

Whilst entering and during the spin the ailerons should normally be held neutral though on some aeroplanes out-spin aileron (i.e. control column to the left during a spin to the right) may be used to advantage. In a few aeroplanes in-spin aileron may be applied to advantage in entering and maintaining the spin.

To recover, first ensure that the throttle is closed,, ailerons neutral and the direction of turn identified. This is followed by application of full opposite rudder. After a brief pause ease the control column forward progressively until the spinning stops. Centralize the rudder and ease gently out of the resulting steep dive, levelling the wings. Stress that the use of power before the nose is on or above the horizon will only result in an increased loss of height.

Point out the large height loss.

RECOVERY FROM THE INCIPIENT STAGE

Carry out the pre-spinning checks. From a straight glide use the controls as for the entry to a fully developed spin. As soon as the aeroplane has stalled and commenced to yaw take the appropriate recovery action. Increase power, apply sufficient rudder to prevent further yaw and ease the control column forward sufficiently to un-stall the aeroplane. Point out that if power is to materially assist recovery action it must be applied before the nose of the aeroplane has pitched too far below the horizon otherwise its use will only increase the loss of height.

SPINS FROM DESCENDING TURNS

Carry out the pre-spinning checks. From a gliding turn at low speed apply excessive rudder in the direction of turn, prevent any increase in bank with the ailerons and move the control column back to maintain the nose position until rotation commences. Take normal recovery action.

Emphasize the danger of misusing the controls and allowing the speed to reduce during a gliding turn, pointing out that a gliding turn is frequently carried out near the ground.

Some aeroplanes will not spin readily as a result of such manoeuvres. When teaching a student on these types the instructor should use discretion in deciding whether or not to demonstrate this exercise, as it has to be convincing to be of value.

RECOVERY FROM SPIRAL DIVE

Complete checks before spiralling. Commence the spiral demonstration without power at a low speed. Initiate the spiral dive much the same as a spin entry but do not apply full rudder or move the control column fully back. In some aeroplanes it is also advantageous to roll the aeroplane towards the required direction of the spiral. Allow the nose to get well below the horizon with the speed increasing then move the control column back. Point out that the spiral tightens as the control column is moved back, that the airspeed is increasing rapidly and the angle of bank is increasing. Point out the indications of the instruments, particularly ASI, altimeter, turn needle and attitude as shown by the attitude indicator if this has not toppled.

To recover, stress the necessity of first ensuring the throttle is closed then levelling the wings, and then ease out of the subsequent dive. Remind the student that any attempt to recover without first levelling the wings will only tighten the spiral and increase both forward and vertical speed.



Extreme care must be taken when allowing the student to practice this manoeuvre to ensure that speed and loading limitations are not exceeded. Rolling 'G' can easily damage an aeroplane.

COMMON FAULTS

Many students forget to close the throttle after entering a spin or spiral dive from a flight condition in which power was being used. This error must be corrected as the height loss will be increased markedly.

Students often attempt to identify the behavior of the aeroplane from the position of the controls. This is not a reliable indication. The spin or spiral must be identified from:

- (i) The flight conditions immediately prior to spin or spiral, i.e. proximity to the stall or high speed, and appropriate attitude
- (ii) The high rate of descent, high rate of turn, and airspeed either building up or remaining steady at a low figure.

In the initial attempts at spin recovery many students fail to centralize the rudder when the rotation stops. This may result in an aeroplane attempting to spin or spiral dive in the opposite direction. Others fail to move the control column forward sufficiently or are not smooth with this movement. Watch for and correct these points.



14 FIRST SOLO

INSTRUCTIONAL GUIDE

A successful and incident free first solo flight gives the student added confidence which is often apparent as an improvement in overall performance. One of the main problems of basic instruction is the recognition or selection of the right moment at which to carry out this exercise. On the one extreme if a student is sent on their first solo too early a poor flight may cause a loss of confidence. However, if the first solo flight is held back too long by an instructor who demands perfection, the student may feel and demonstrate a sense of frustration.

The main requirement is not for polished flying but general competence and safety and an ability to correct faults. The instructor must be sure that the student can take the appropriate measures in an emergency. If no emergencies have arisen in the course of normal training, the instructor should have simulated them and noted the student's reactions.

The following is a guide to what constitutes an acceptable standard for the first solo flight:

- (i) **Stall and Incipient Spin** The student must be proficient at recognizing the approach of the stall in the take-off, cruise and approach configurations, and shall have demonstrated the ability to recover from a stall and incipient spin.
- (ii) **Take-Off and Climb** The student should be able to maintain a straight path and fly off at a safe speed. Checks must be of a good standard and the student must be able to keep a good lookout whilst performing these checks.
- (iii) **The Circuit** Although the circuit need not be precise in all respects, the student should be consistent in maintaining the approximate length of each leg and a satisfactory heading. Minor variations in altitude are acceptable providing the student is able to detect and correct them and they are not large enough to cause marked difficulty in judging the approach or traffic separation problems.
- (iv) **The Approach** The student should have good control of the speed particularly during the final turn and last stages of the approach and should be able to anticipate the need for power adjustments and the necessity for going around again. These decisions must not be left until the last moment.
- (v) **The Landing** The landings must be safe with no consistent faults such as holding off too high. A series of good landings is not necessarily proof of readiness for solo unless the student has shown that he or she is also able to recognise the need to go around again safely in the event of a mis-landing.
- (vi) **Airmanship** The student must keep a good lookout without constant reminders from the instructor. All flight checks and drills should be faultless. There should be no doubt about the student's ability to avoid other aeroplanes, land on the correct runway and follow ATC instructions (if applicable).
- (vii) **Emergencies** The student must have had practice at handling engine failure after take-off and should have had practice at making glide approaches in the unlikely event of engine failure elsewhere in the circuit. The student is also expected to be proficient in giving a pre take-off safety brief.

Only a short briefing is necessary and this can be given while taxiing to the take-off point. The student should be reminded of any special points such as air traffic requirements, wind conditions, etc. Brief to do only one circuit and landing but not to hesitate to go around again if necessary. If possible the traffic density should be low and ATC informed if in operation.

The student should also be reminded that the aircraft will probably get airborne quicker than expected and float longer on landing due to the lighter weight.

ADDITIONAL GUIDANCE FOR INSTRUCTORS

Instructors without first solo privileges should hand over their student to a senior instructor at least two trips before they think the student will be ready for the first solo flight.

Ideally, a student should be given minimum prior notice of his / her first solo flight. Anticipation of the event can lead to deterioration in performance or disappointment if it does not occur when anticipated.

The instructor should also ensure the seat belt is secure and the door / canopy is locked on vacating the aircraft.



15

EMERGENCY AND SPECIAL PROCEDURES

AIM

To teach the student how to carry out a safe approach and landing following an emergency and to consider the action in event of fire.

INSTRUCTIONAL GUIDE

A forced landing due to mechanical malfunction occurs only very rarely with modern aeroplanes. A forced landing due to poor airmanship should in theory never occur. In practice it occasionally does. The pilot must have an understanding of how to cope with emergencies during which he or she may or may not have the use of engine power and during which the student may have to land the aeroplane away from a prepared aerodrome or even ditch it. The forced landing procedures to cover these contingencies will differ. If power is available there is time to act deliberately and think through the problem, perhaps even seeking assistance on the radio. If no power is available a quick decision and sound judgment are the essentials especially after take-off or during low level operations. If the aeroplane is to alight on land then the actual landing should have already been practiced. On water a different technique has to be applied. For these reasons the exercises are dealt with separately.

Before leaving the circuit on solo flights the student should have had some instruction in forced landings without power and should have grasped the basic requirements of the exercise. The student cannot of course, be expected to be fully proficient at this early stage.

The ultimate aim in practicing forced landings is to make the student so familiar with the procedure that, should he or she be faced with such an emergency, no time will be wasted on what to do and how to plan an approach.

In the early attempts the instructor should carefully point out the field to be used, should allow the student to practice several approaches from the same height and should place the aeroplane in an ideal position relative to the field. As training progresses the task should be made progressively more difficult. Heights and positions should be varied and different fields chosen. When the student has reached a suitable basic standard the practice can be made more realistic by closing the throttle without warning at various heights and under various conditions.

Given the relative complexity of a forced landing due to the number of expected actions, a GFPT or PPL applicant should be able to complete all the checklist actions from about 2,000 feet AGL and a CPL applicant from about 1,000 feet AGL.

Note: Whilst the thrust of this manual is towards simple fixed undercarriage training aeroplanes it does no harm to mention the following undercarriage considerations to a student.

When forced to carry out a landing away from a prepared surface the position of the undercarriage, if retractable, must be considered. If the aeroplane has a tricycle undercarriage it is generally advisable to land with it in the locked down position. By doing so the risk of injury is minimized, since the initial impact is cushioned by the undercarriage and the fuselage may be held clear of smaller obstructions. Full brake can be applied immediately after touchdown.

In the case of an aeroplane fitted with a tail wheel the undercarriage should be retracted if possible. If this is not done there is a risk of the aeroplane nosing over and coming to rest in the inverted position. If the pilot is certain that the surface is good and the length adequate it may be possible to land with this type of undercarriage locked down.

When forced to ditch an aeroplane the undercarriage should invariably be retracted if possible.

PRE-FLIGHT BRIEFING CONSIDERATIONS

COMPLETE ENGINE FAILURE

When a complete engine failure occurs the fundamental considerations are those of time and height. However, the immediate actions are normally to close the throttle, speed to height (or for distance), check for fire, trim for the glide and conduct initial trouble checks.

The next action must be to choose a suitable landing area bearing in mind the wind speed and direction (which should be known at all times) and the student must be briefed on how to make the most of the restricted choices available. Figure 15-1 shows the descent profile to the intended landing area and suggested procedures. Figure 15-2 shows a method of selecting a landing area. The field must be within easy gliding distance. Ideally it should have a long run into wind, a good surface, and no

obstructions particularly on the approach, and be near where assistance is available. The best indications of wind direction are obtained from a windsock and smoke or dust. The movement of cloud shadows is a good indication, particularly if the clouds are not very high. Wind lanes on water are useful. Failing any of these indications the take-off direction and forecast winds should be used as a guide. When low down, the drift of the aeroplane may also give a good indication of wind speed and direction.

The student should be briefed that whilst a landing into wind is normally preferable, it might on occasions be advantageous to land across the wind. It may be that a long run with an acceptable cross wind component would provide a safer landing area than a short run into wind. If the wind is very strong the long run could not be used and the short one might be adequate. It is usually preferable to land uphill but down wind rather than downhill but into wind.

Figure 15-1: Engine failure descent profile and procedures.

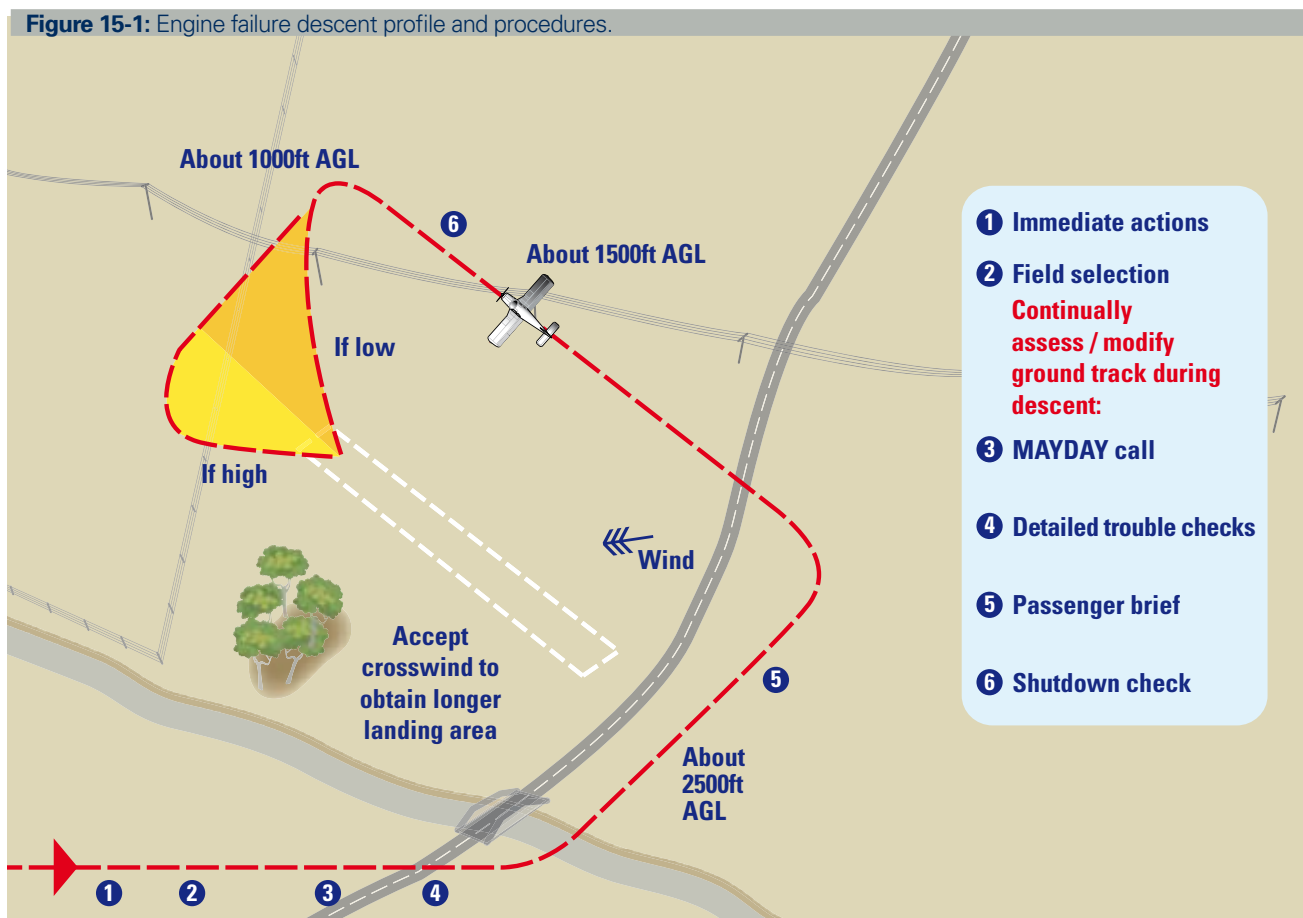



Figure 15-2: Mnemonic for selecting a landing area.

MNEMONIC FOR SELECTING A LANDING AREA

- W**ind – speed & direction
- O**bstacles – above ground
- S**ize – in relation to wind
- S**urface – condition/type
- S**lope – may land uphill downwind
- S**hoots – undershoot & overshoot
- S**un – if possible do not land looking into the sun
- C**ivilization – near to a homestead if possible

Some indication must be given to the student as to the relative merits of various surfaces.

Obviously an aerodrome or prepared airstrip is the best choice. A disused aerodrome is usually satisfactory. Pasture will probably be the next best choice and stubble usually provides a fairly good surface. If ploughed land has to be used land along the furrows if possible. Standing crops should be used only as a last resort and beaches should be treated with caution though they may, in fact, be very good. Local knowledge is invaluable and practice at choosing fields should be continued right through the student's training.

Having selected the field and landing direction a plan must be formulated. This depends principally on the height available and distance to the field. If the aeroplane is say, 5,000FT above the field it will probably be advantageous to fly around the field. In any case the aeroplane must be flown to a position some 1,000FT above ground level which is, in effect, on the base leg relative to the chosen field and from which a comfortable glide into the field can be made. Explain that the altimeter does not necessarily give an accurate indication of the aeroplane height above the ground.

Demonstrate the procedure to the student on a whiteboard, on paper or by electronic means. Draw a plan of a field and mark the areas at which the aeroplane should arrive in order to carry out a glide approach, aiming to land well inside the field. Discuss the methods of arriving at this point, assuming engine failure at various positions relative to the field and at various heights. Explain that it is really a question of getting there in the simplest way.

Brief the student that having chosen the landing area and planned the descent on the assumption that the cause of

the engine failure cannot be rectified, it is now necessary to look for the cause of failure. Re-check the fuel, ensuring that a tank containing fuel is selected.

Check that ignition switches, mixture control, carburettor air, and other engine controls are set for operation. If the engine has stopped rotating set the controls and try the starter unless there are obvious symptoms of mechanical failure. As soon as a forced landing becomes inevitable the student should be briefed concerning the contents of a distress call. It should be stressed that this call be broadcast as soon as possible as the greater the height of the aeroplane the better the chance of the call being heard. The student should be briefed that if the engine cannot be re-started the fuel and ignition switches should be turned off at or before reaching the 1,000FT area. Point out that in some aeroplanes the master switch must remain on until the final flap selection is made. All seat belts should be tightened by this time and a simulated passenger brief given.

Explain how you intend to demonstrate the approach, emphasizing the way to adjust the base leg by either turning slightly away from the field if too high or turning in early if rather low. Explain the use of flap, pointing out that this should be restricted initially to leave as much variation of control as possible over the angle and rate of descent. The considerations are the same as for a glide approach except that when absolutely sure of getting into the field full flap should be used unless some aeroplane peculiarity makes this inadvisable.

The subsequent actions after landing will depend on the location of the aeroplane. If the landing has been made in desolate country the question of survival is the dominant one and this is outside the scope of the pre-flight briefing for this exercise. Generally some form of habitation should be sought and the appropriate authorities should be notified. The student should be reminded that search and rescue signals and information are contained in the Aeronautical Information Publication.



AIRMANSHIP

This exercise is practiced only in an approved area or at special ALAs approved for the purpose. Since several aeroplanes may be practicing at these fields a good lookout is essential at all times.

During dual exercises the descent should be continued down to a position from which it is possible to determine without doubt the success, or otherwise, of the exercise. At certain suitable locations a touchdown might even be possible. Instructors must brief students on the minimum height to which they may descend whilst solo. This height will normally be not below 500FT AGL

To reduce the incidents of spark plug fouling plug briefly increase power to the cruise setting every 1,000FT or use other specified procedures.

In a real emergency the decision as to whether or not to switch off the engine is governed largely by the following two considerations:

- (i) If the failure is definitely mechanical it should be switched off immediately
- (ii) If the failure is partial, resulting in reduced or intermittent running, the engine may be used at the pilot's discretion, remembering that it may pick up temporarily or fail again at a critical stage. In such a case it is probably best not to rely on the faulty engine and to assume a total failure.

Note: The engine failure should be simulated only by closing the throttle. Ignition switches and fuel tank selectors should not be moved during practices.

PRECAUTIONARY SEARCH AND LANDING

For a variety of reasons other than engine failure a pilot may be faced with the decision to land away from a prepared surface. These reasons are nearly always due to faulty navigation, poor planning (running out of fuel or daylight) or encountering bad weather and this cause is also often due to poor planning.

From the outset the student must understand that should any doubt exist as to the advisability of continuing the flight the decision to land must be made whilst there is still time to do so with the aeroplane under full control and before conditions deteriorate to a dangerous level.

For the purpose of the exercise it is as well to brief the student that conditions of poor visibility with a low cloud base and limited fuel will be simulated.

Once the decision to land has been taken a suitable landing area must be sought immediately. The considerations regarding size, surface, freedom from obstructions and wind direction are essentially the same as those for the exercise involving complete engine failure. As soon as a likely area has been sighted it should be inspected thoroughly.

Draw a plan of a field for the student and brief on how to fly parallel to and normally to the right of the proposed landing path. This run should be made with the optimum flap setting at slow cruising speed. This preliminary inspection should be sufficiently low for the surface to be inspected but not so low that it is necessary to avoid obstacles. Another point to impress on the student is that the inspection runs should be made at a constant height whilst safely avoiding upwind obstacles. If not satisfied with the surface complete at least one other inspection run at a lower height if necessary.

When satisfied with the area, complete a circuit keeping the field in sight. Position the aeroplane for a short field landing.

When the surface wind is other than light and variable, flying into wind will produce a noticeable reduction in ground speed. When flying down wind the increase in ground speed may be so noticeable that under extreme conditions a student may be tempted to reduce airspeed, which is dangerous.

Brief the student that when the wind is strong enough to produce drift, this makes turns deceptive. When turning down wind from into wind the aeroplane gives the impression of slipping in. The converse applies when turning from down wind to the into wind position, in this case the aeroplane appears to skid out. These impressions are optical illusions and rudder must not be used to correct this apparent unbalance without confirmation from the balance indicator that the application of rudder is necessary.

Although these are optical illusions the drift is real. Care must therefore be taken to ensure that the student allows plenty of room when turning from down wind into wind inside a confined area.



AIRMANSHIP

With good airmanship the student should rarely be forced into a position to have to carry out this procedure.

The decision to land must be made in ample time before fuel runs out, before it becomes too dark or before the weather deteriorates to a dangerous level.

The need for a really good lookout whilst carrying out this low flying exercise cannot be over-emphasized.

Turns must be accurate in spite of the deceptive appearance of the ground.

This exercise must be practiced only in approved areas or at approved fields and even then all effort should be made to avoid frightening livestock and annoying people. Point out to the student that it is good airmanship to apply the inspection technique to a landing ground, other than a recognized aerodrome, with which you are not familiar. It may not be necessary to carry out a short landing in all cases though of course no harm will be done by adopting this technique.

ACTION IN THE EVENT OF FIRE

Fires in the air and on the ground are both rare occurrences. Nevertheless, the student must receive a briefing on how to cope with these emergencies. One of the main points to cover is to ensure that the student is conversant with the position and method of use of every fire appliance in the aeroplane.

FIRE ON THE GROUND

The most common causes of fires on the ground are fractures allowing leakage of oil or fuel under pressure. These causes are associated with rotation of the engine. It follows that the student must be briefed that to close the throttle is invariably the first action to be taken should fire occur. Fuel and ignition switches must be turned off. Fire extinguishers should be operated if the fire shows no sign of abating.

Fire may also be caused in some engines by over-priming or even by facing the wrong direction in a strong wind thus allowing excess fuel to accumulate in exhaust systems.

If fire, other than fire associated with the engine, is detected, electrical systems should be switched off and the appropriate fire extinguishers used. Engines should be stopped and passengers and crew should disembark. Remind the student of the very toxic effects of some types of extinguishing fluids.

FIRE IN THE AIR

Fire in the air, though a most infrequent occurrence, is primarily caused by leakage of oil or fuel under pressure. The student must be briefed to stop this leakage by closing the throttle and turning off fuel and ignition switches. The most appropriate fire extinguishers should be used if possible.

A slide slip may be useful in directing smoke and flames away from the cabin area and may even put the fire out. In any case the student must be briefed that a forced landing will almost invariably follow as it is most inadvisable to attempt to re-start the engine.

If a fire other than an engine fire occurs in the air any associated electrical circuits should be turned off. Extinguishers should be used bearing in mind the specific uses for each type. Cabin ventilators and windows should be opened to get rid of smoke and toxic fumes and the aeroplane landed as soon as possible.

DITCHING

The possibility of being faced with the decision to ditch an aeroplane is remote. Even so an instructor should spend a few minutes briefing the student on the best way to tackle this problem, should it arise.

The aeroplane should always be ditched into wind if the surface of the water is smooth, or if the water is smooth with a very long swell. In a very pronounced swell or rough sea the best plan would be to land along the swell, accepting if necessary, the cross wind and higher touchdown speed. The danger of nosing into large waves during an into-wind ditching is very great and should be avoided.

If faced with a ditching the pilot should already have a good idea of surface wind direction. In general, waves move down wind except when very close to the shoreline, or in fast moving estuaries. Remind the student that swell does not necessarily bear any relation to the surface wind direction.

Wind lanes may be apparent, the streaked effect being more pronounced when looking down wind. When the surface is unbroken, gusts may sometimes ripple the surface in great sweeps which indicate the direction of the wind. As the aeroplane nears the water the drift will give a good indication of wind direction.

Water always appears from the air to be calmer than it is. If possible fly low over the water and study its surface before ditching.



Brief the student that the speed and rate of descent should be as low as possible consistent with safe handling. A tail-down attitude should be adopted when touching down by holding off until excess speed is lost so that the speed at the instant of impact is as low as possible.

The value of power during ditching is so great that if a pilot realizes a ditching is inevitable and still has engine power available, the ditching should be conducted prior to running out of fuel. If power is available the water surface can be inspected to decide upon the best landing direction and the slowest touchdown made.

Flaps should be used, though in general should not be lowered beyond the optimum setting. To lower them further will increase the rate of descent and may well impair the ditching characteristics of the aeroplane.

The undercarriage should be retracted if possible.

Pilots must be briefed to warn passengers and crew not to relax or move until the aeroplane has come to rest. They should be prepared for a double impact, the first when the tail strikes and then a second and greater shock as the nose hits the water. They should also be prepared for the aeroplane to slew to one side.

Action after ditching will depend on the amount of lifesaving equipment available. However, all persons should wear life jackets when flying over water, except if the over water operations only involve take-off or landing.

AIR EXERCISE

- (a) Forced landing—complete engine failure
- (b) Precautionary search and landing

FORCED LANDING—COMPLETE ENGINE FAILURE

The following sequence of events is one way of conducting a forced landing following a complete engine failure:

- Initial actions
- Throttle closed
- Speed to height or distance
- Check for fire
- Trim for glide
- Brief check of fuel management plus Temps & Pressures
- Select general area for landing

- Mayday call
- Detailed trouble check & possible engine restart attempt
- Detailed landing area selection & associated letdown profile
- Passenger brief
- Shutdown checks

As it is a practice forced landing open throttle to cruise setting at least every 1,000FT of descent.

At the 1,000FT area carry out a normal glide approach using full flap when sure of getting into the field.

Point out how to adjust this final approach by either turning away from or towards the field, by using a longer base leg, by judicious use of flap, or by sideslipping as applicable to the type of aeroplane.

When sure of the outcome of the exercise point out the height to which the student may descend whilst solo and then carry out the procedure for going around.

Give the student plenty of practice, varying the height and distance from various fields when simulating failure of the engine.

PRECAUTIONARY SEARCH AND LANDING

When in a suitable area descend to about 500FT above the ground and tell the student to assume poor weather conditions with a cloud base of about 600FT and poor visibility.

Choose a suitable airstrip and demonstrate how to inspect the surface. Fly at low safe cruising speed with the optimum flap setting. Fly over the field slightly to the right of the intended landing path at about 100FT to make the first check. On this run check the surface and drift and note any high ground and obstacles in the overshoot area. Climb up to about 500FT and make a circuit keeping the field in sight and placing the aeroplane in a favourable position to make a dummy approach, again to the right of the landing path. On this approach re-check the surface and drift. Repeat the circuit and if quite satisfied with the surface carry out a short field landing procedure or go around procedure.

Give the student plenty of practice at this exercise. During the initial attempts point out the effects of drift near the ground which give rise to optical illusions.

Practice at various fields assuming different weather conditions and ensure that the student is competent at this exercise before authorizing solo practice.



16 PILOT NAVIGATION

AIM

To teach the student how to navigate the aeroplane under visual meteorological conditions using pilot navigation methods.

INSTRUCTIONAL GUIDE

Pilot navigation means that navigational activity which can be carried out by the pilot when flying an aeroplane. The scope of this activity is limited by the confined space of the cockpit and the fact that the pilot's attention is divided. Therefore, it is necessary to keep to a minimum the procedure involved.

When introducing this sequence to the student the flying instructor must emphasize that the mental processes required are simple and that the methods are based on common sense. As the ability to navigate is an integral part of the art of flying an aeroplane, it should never be regarded as being in any sense an addition to a pilot's normal activity.

During earlier training the student should have gained a good appreciation of the use and vagaries of the magnetic compass as well as the directional gyro. In addition, whilst flying in the local area the student should have been given some elementary instruction and practice in map reading, particular emphasis having been placed on proper orientation of the map and the relating of features on the map to features on the ground. Elementary exercises in the estimation of distances, bearings and headings to reach a chosen point are also very valuable.

Instructors must ensure that adequate time is allotted to post-flight discussion. Investigating mistakes and difficulties is one of the best ways of improving pilot navigation.

The number of navigational exercises which will be flown during the student's training will depend on the requirements of the syllabus and upon the student's ability. The information which follows represents the essential instruction which should be given, and must be incorporated in the most appropriate way in the student's training.

PRE-FLIGHT BRIEFING CONSIDERATIONS

FLIGHT PLANNING

The successful completion of a navigation flight is largely dependent upon pre-flight preparations and planning. The instructor must therefore impress upon the student the importance of completing the pre-flight preparation in a thorough and systematic manner. The following order is suggested:

- (i) Weather
- (ii) Preparation and study of maps
- (iii) Preparation of flight plan
- (iv) Filing of flight plan or flight notification

A forecast and NOTAMs to cover the route should be obtained by facsimile message or from the internet.

Point out to the student how to interpret this forecast to ensure that the whole flight can be conducted under Visual Flight Rules. Particular attention must also be given to the wind velocity at the height at which the flight is to be undertaken as strong winds may seriously affect the ground speed of the aeroplane.

Having completed the meteorological study, the next step is to brief the student on the preparation and study of the maps and charts to be used on the flight. It is important that the student be taught to make intelligent use of the appropriate en-route and terminal charts in conjunction with the appropriate topographical charts. On the appropriate chart have the student draw in the required tracks, bearing in mind the necessity to use lanes of entry, the need to avoid, or to take the necessary action to enter, controlled airspace, restricted airspace and prohibited areas. Bear in mind also the suitability of terrain in case of a forced landing and the location and frequency of check points. Show the student how to select unmistakable check features every 20 miles or so along the track. These check points should be features on or near the intended track and of such prominence that the pilot-navigator can easily fix his or her position when they appear.



Ensure that the student is aware of the major factors influencing the choice of cruising levels. These factors are the wind velocity, cloud en route, terrain clearance and the necessity to conform with the selection of cruising levels both outside and within controlled airspace.

At the flight planning stage it is also important to decide on the Search and Rescue (SAR) protection available and to know the way it may be achieved.

Show the student how to determine cruising speeds and fuel consumption figures from the cruising charts shown in the aeroplane's Flight Manual or Owner's Handbook.

When preparing the flight plan ensure that the student has completed it accurately and legibly. Insist that the student always estimates the distances, headings and time intervals before measuring or calculating. This applies also to the estimation of fuel requirements. In this way a double check of the flight plan is made. Brief the student on how to lodge the flight plan or flight notification, or SAR requirements.

Finally, remind the student of the fuel reserves that must be carried, also of the importance of terminating the flight with a suitable margin before last light.

DEPARTURE

The student must be briefed on the method of departure. In the early stages it is advisable (but often not practical) to make an accurate departure from a point directly over the airfield.

Ensure the student is aware of any procedures and restrictions which must be complied with on departure. Impress on the student the necessity to log the departure time and to ensure within the first few minutes that there is no gross heading error and is in fact making good the correct track.

EN ROUTE

Impress on the student that accurate heading keeping is essential to the successful outcome of the cross-country flight. Where a directional gyro is used remind the student of the necessity to ensure that it is aligned with the compass at frequent intervals.

It must be stressed to the student that after the compass the aeroplane's clock (or a watch) is navigationally the most important instrument, as the time factor is vital in fixing a position. With a knowledge of the flight planned time intervals between check points, regular reference to a time piece will provide an approximate but continuous indication of the aeroplane's position, the value of which is sometimes overlooked by the student when too intent on map reading. In essence the normal emphasis is on time, then map followed by ground.

'ONE-IN-SIXTY' RULE

Before commencing cross-country flying the student should have gained through ground lessons a good working knowledge of the 'one-in-sixty' rule. Refresh the student's memory on this point. Remind the student that it depends on the fact that after traveling sixty miles a distance of one mile off track represents a track error of approximately one degree, two miles two degrees and so on. It is not necessary to travel sixty miles to make use of the rule; for example three miles off track after ten miles traveled is equivalent to eighteen miles off track after sixty miles which represents a track error of eighteen degrees. In the initial stages the student should be briefed to regain the track by doubling the track error and flying the new heading for the same time it took to build up the track error. This should put the aeroplane back on the required track, then flying the original heading, plus or minus the track error, should keep it there.

The use of ten degree drift lines can also assist in the application of this rule.



LOG KEEPING

The student must be briefed on the method of keeping a log in the air. The primary purpose is to record sufficient data to enable the pilot to fix the aeroplane's position at any time. This data is invaluable should the pilot become unsure of his or her position. Another requirement which is automatically met by a good flight plan and log is that the information required for radio position reporting is readily available. Additionally, in the event of an emergency the position of the aeroplane can be more easily determined. A good log also helps the student to understand the methodical sequence of navigational activity and greatly assists in post-flight analysis. Except for short flights a pilot cannot mentally retain all the details to satisfy these requirements. For the pilot-navigator a good log does not imply rows of neatly printed words and figures but rather that the in-flight log should show the pilot where he or she is, or should be, at the given time. The log should therefore record the departure time, fixes and time of each fix, changes of headings and airspeed and times of making them, ETA's and revised ETA's whenever found and the times of arrival at turning points and destinations. The instructor must stress the importance of checking and re-checking the ground speed whenever the opportunity arises. This particular facet of pilot navigation becomes doubly important when flying over featureless terrain. These entries can be made on the log part of the flight plan form, or even on the map if it has been specially prepared, e.g. with a plastic cover and using a china-graph pencil.

MAP READING

Correct map reading is a particular means of fixing the aeroplane's position and it must be considered as the chief navigational aid to flight in visual meteorological conditions. However, the student must be briefed to understand that map reading should only be used as an aid to, and not as a method of, pilot navigation. Students must be briefed this way because there is a tendency for the learner to feel that the process of fixing position by looking at the ground should be an almost continuous one. Therefore the non-appearance of any particular check feature may cause unwarranted anxiety resulting in large alterations of headings, a lost sense of time and finally in becoming lost. Map reading therefore must be looked on as an aid to pilot navigation, the fundamental principle of which is deduced (dead) reckoning.

The student must understand that there are four basic

factors upon which the success of map reading depends. These are knowledge of direction, knowledge of distance, identification of features and the selection of landmarks. To help the student in his knowledge of direction brief on the method of orientating the map. By doing this the student will relate the direction of land features to their representations on the map, so aiding recognition. With the map orientated it also becomes easier to compare distance between landmarks on the ground with their corresponding distances on the map, thus helping the fixing of position. The combination of the first two basic factors makes the identification of features possible.

The basic principle governing the selection of landmarks is the ease with which they can be identified and the student must be briefed in the selection of these landmarks with this in mind. The conspicuousness of any feature depends on the angle of observation, the dimensions and the uniqueness of the feature. At low levels features are recognized by their elevation, as height is increased the plan outline becomes more important.

The dimensions of a feature play a great part in determining its usefulness in map reading. A feature which is long in one direction and sharply defined in the other is often useful. The length makes the feature easier to see despite airframe restrictions on some aeroplanes to downward vision, and its shorter dimension often permits an accurate estimation of position relative to the feature, either in tracking along it or in timing the movement of flight directly above it. To avoid ambiguity the ideal feature should be unique in that it should be the only one of its particular outline in the vicinity.

A student will be carrying out solo cross-country exercises only in good weather conditions which permit continuous visual observations of the ground. The student must understand that with a knowledge of the flight planned or actual ground speed, it is possible to look for a definite feature at a definite time. Under these conditions you must map read from map to ground. Having identified the selected feature a positive check on additional ground detail surrounding the feature should be made.



LOW LEVEL NAVIGATION

This exercise should be carried out to give a terrain clearance of no less than 500 feet for the route segments in question.

Low level navigation is based on the same conventional methods as normal pilot navigation. The difference is that the field of view is restricted and the time available for recognition of ground features is much reduced. At low level, navigation becomes a mixture of mental plotting and high speed map reading.

The student must be briefed on the particular differences in pre-flight planning for the low level exercise. Show how to choose features both in number and type with a special view of their value as aids at low altitude.

Spot heights are frequently excellent features to recognize at low level. Projecting edifices such as high monuments, towers, silos and factory chimneys are very useful at low level but may in fact be almost invisible when high up. In addition it may not be possible to fly on a direct track as built up areas may lie on this track.

The student must think ahead and be alert for the appearance of the check features, and must make reasonably quick decisions in recognizing them. If a feature fails to appear there will be no time to be concerned but the student must concentrate on looking out for the next one. The number of check features required is in general greater at low level than for a similar flight distance at normal height.

At low level, log keeping is restricted to fewer entries because of aeroplane handling considerations, and at times it may not be possible with safety to make log entries.

RANGE AND ENDURANCE

As students progress with navigation techniques they should be made fully aware of the basic principles involved in range and endurance flying and in particular, should be fully aware of the particular configurations applicable to the type of aeroplane in which they are training in.

RANGE FLYING

The following points should be stressed in a briefing on this subject:

- (i) From the point of view of the airframe it must be flown at the IAS corresponding with the best obtainable lift/drag ratio. This IAS will remain the same whatever the height but will increase or decrease slightly depending on the weight of the aeroplane. For practical purposes in light aeroplanes this factor can be ignored and the one IAS applied to a particular type of aeroplane.
- (ii) From the point of view of the engine there is a best height at which to fly. This height will depend upon the engine type and the propeller fitted. A normally aspirated engine fitted with a fixed pitch propeller is usually most efficient at sea level. Therefore the height to fly in this case would be as low as possible consistent with safety. Where the same engine is fitted with a constant speed propeller, a combination of high manifold pressure and low RPM will normally give the best air miles per gallon, the height here being dependent on engine type and propeller. In all cases the student's attention must be drawn to the performance charts prepared by the manufacturer for the particular aeroplane. Weak mixture should be used and the carburettor heat kept 'cold' whenever possible. The student must be briefed to consider the effect of the wind, and the possibility of flying at an altitude other than that recommended to reduce a possible head wind component or take advantage of a tail wind component.

ENDURANCE FLYING

The speed for endurance flying is the speed at which the engine is required to deliver the minimum power necessary to maintain height. Manufacturers recommend an endurance speed and this does not vary with height. However, the engine power required to achieve this speed does increase with altitude and therefore from the point of view of the engine the aeroplane should be flown as low as possible.

Point out that wind has no effect on flying endurance.



CROSS-COUNTRY EMERGENCY PROCEDURES

The principle cause of getting lost is undoubtedly human error. The student pilot must clearly understand that there is a great difference between being uncertain of your true position whilst knowing your DR position and being completely lost.

The instructor must point out that it is impossible to give a set of rules which will cater for all circumstances and must stress the futility of aimlessly flying around in the hope of finding a pin-point.

If a student thinks he or she is lost, the first action should be to decide on what was the last positive fix, then check the headings steered since that fix. Ensure that:

- (a) the directional gyro is aligned correctly with the compass
- (b) the variation and drift are correctly applied
- (c) the estimation of track direction on the map against that shown on the flight plan is correct and
- (d) the magnetic compass is not affected by interference such as a portable radio or camera placed close to it.

The next step should be to establish the most probable area over which the aeroplane is now flying. This may be done by estimating the distance flown since the last fix and applying this distance, plus or minus 10%, to an arc 30 degrees either side of the probable track made good. Now check features in this area of the map against what may be seen on the ground.

If still unable to fix position, the pilot should now consider taking one or more of the following actions:

- (a) seek navigational assistance from ATS. Pilots are frequently reluctant to take this step, fearing subsequent 'Incident Report' action. The instructor should emphasize the wisdom of seeking such help at an early stage rather than as the final resort, or
- (b) steering the reciprocal heading and attempting to return to the last fix, or
- (c) climbing to a higher altitude, thereby increasing the range of vision, or
- (d) turning towards a known prominent feature, such as coastline, mountain range, railway line or large river.

Whilst carrying out any of the foregoing actions, the instructor must emphasize the importance of keeping

the navigation log going. One feature by itself may not establish the position but two or more within a reasonable time may give the clue. The information in a navigation log may also be of great assistance to ATS or other persons trying to assist the pilot. Remind the student to determine a safe endurance and also to consider flying the aeroplane for maximum range.

When the position is apparently established the importance of doubly checking all features must be stressed.

The student must be briefed on the actions to be taken in the event of encountering adverse weather, shortage of fuel, running out of daylight, or a partial unserviceability. Stress the importance of never hesitating to turn back or diverting to a suitable alternative landing area. Finally, point out that if for any reason the pilot considers it necessary to land on an unprepared surface it is essential to carry out an inspection of the selected area before landing. Remind the student of the information contained in the Aeronautical Information Publication concerning actions to be taken after such a landing.

USE OF NAVIGATION AIDS

If the aeroplane used for the training is equipped with any type of navigation aid designed to interrogate a ground based aid, a self contained navigation system or satellite navigation system, the student must be taught how to use the equipment to assist with visual navigation. Such training would need to include how to tune, and identify the station selected, testing of the equipment, operating ranges and limitations on use.

AIR TRAFFIC CONTROL PROCEDURES

A thorough briefing must be carried out on the ATC procedures applicable to the route to be flown. Particular emphasis must be laid on the use or avoidance of controlled airspace and the use of lanes of entry where applicable.

AIRMANSHIP

The student must not neglect lookout and accurate flying while engrossed in navigational matters. See that the student does not develop any laxity in these areas.

Weather conditions must be constantly observed during cross-country flights. Any deterioration in weather must be carefully assessed and appropriate action taken to avoid flight in hazardous conditions.



AIR EXERCISE

- (a) Departure
- (b) En route
- (c) Low level navigation
- (d) Lost procedure
- (e) Diversion procedure
- (f) Air traffic control procedure

On the first cross-country exercise, the student should be encouraged to accept as much of the work load as possible, but the instructor should assist by flying the aeroplane when the student has any difficulty. Ask questions and give help as required, pointing out the essential features of the exercise. On the second and subsequent cross-country flights the student should do both the flying and navigating.

DEPARTURE

After take-off, climb and turn so as to arrive over the airfield at the correct altitude, heading and airspeed.

If this is not possible due to airspace restrictions, depart on the appropriate heading using the recommended en route climbing speed for the particular aeroplane.

Tell the student to log the time of departure and calculate his ETA at the first check point. Ensure that the heading is accurate and stress the importance of synchronizing the directional gyro. Demonstrate how to make a commonsense check (i.e. a gross error check) of the heading by use of local features.

EN ROUTE

When at cruising altitude, demonstrate how to set the desired power and lean the mixture. Have the student check the compass frequently. Ensure that the student map reads correctly by demonstrating the correct orientation of the map and show how to map read from map to ground. Stress the anticipation of pinpoints by DR calculations. Point out how distance estimation is affected by altitude, the relative value of ground features and the use of distant features as a rough guide to position and heading. Unless the error is very great do not try to correct track error until the first check feature. As the flight progresses show how to apply the 'one-in-sixty' rule.

Insist that the student is accurate in flying headings, speeds and heights or flight levels.

As soon as possible demonstrate how to obtain a ground speed check, showing how to revise ETAs at check features and destination. Stress the importance of logging such information.

When approaching the ETA of the destination warn the student to map read more carefully and to be prepared to make a large change of heading.

During the en route phase of the flight encourage the student to obtain pin-points, when plentiful, at no greater intervals than about every ten minutes.

After logging a pin point, changing heading or at about 15 minute intervals it is advisable to conduct checks which encompass all the following applicable items. The mnemonic **FCLEAR** is suggested if there is no other procedure specified:

Fuel (management) – amount remaining, check against planned consumption, consider need to change tank, power setting, mixture and use of carburettor heat

Compass, check directional gyro and check for gross error after a heading change

Log pertinent detail

Engine, check temperatures and pressures

Altimetry, check for correct altimeter sub scale setting

Radio, ensure correct frequency and volume setting, make call if required

LOW LEVEL NAVIGATION

During this exercise point out the special conspicuous features which were chosen during the flight planning stage as being easily recognizable at low level. Point out their changed aspect and relative importance compared with higher level navigation.

Stress the limited field of vision and show that there is great need for anticipation and quick recognition of features. Impress again that to achieve this, careful pre-flight map study was essential.

During the flight it is quite likely that a few of the check features may pass unnoticed by the student. Point out that it is here that mental DR is invaluable in determining position. Therefore, if the appearance of any check feature is according to the dead reckoning overdue, always assume that it has been passed and tell the student to be in readiness for the next.



For the above reasons map preparation for planned low level navigation will usually be to mark the track at two minute intervals. For higher level navigation, maps are often marked along the intended track at 20 nautical mile intervals.

Whilst it should never be necessary for the pilot of a civil aeroplane to navigate at less than 500 feet above ground level it must be stressed during this exercise that a very good lookout must be maintained. The presence of unusually high and difficult to see obstructions and built up areas must be anticipated and avoided.

EMERGENCY PROCEDURES

LOST PROCEDURE

Students will often believe themselves lost during their navigation training. If this happens make use of the situations by demonstrating the lost procedure.

If the student does not become lost then he or she should be made uncertain of the aircrafts position by use of:

- simulated instrument flight; or
- denied use of a map; or
- simulated compass failure; or
- other similar methods.

In the early stages of demonstrating this exercise allow the student to keep a log of all times and headings flown. Later however, make the student establish your position without being armed with this knowledge.

In all cases teach the student first to establish a circle of uncertainty. This is centered on DR position with a radius of 10 per cent of the calculated distance from the last fix. If en route continue to fly to the next check point, meanwhile map reading from ground to map. At ETA continue to fly for a further 10 per cent of the flying time since the last fix. If by this time the student has not established a positive position, demonstrate how to choose a prominent feature, preferably a long line feature and head for this feature.

Point out that this exercise is a good opportunity to put into practice the range flying procedures. When a pilot becomes lost en route the aeroplane should be flown in the configuration to give maximum range.

DIVERSION PROCEDURE

At some stage during a cross-country exercise, simulate deteriorating weather conditions necessitating an unplanned diversion to an airfield other than the point of departure or destination.

Have the student pass you a new heading and ETA for this destination and have the student fly for range during this leg.

To make the exercise more realistic introduce simulated conditions so that the student has to hold some way from the alternate aerodrome for an indefinite time. This time should in practice be only long enough to set up the aeroplane configuration for maximum endurance.

USE OF NAVIGATION AIDS

Once the student has demonstrated proficiency in pilot navigation techniques, the use of navigation aids to assist with navigation should be introduced. The student needs to be able to switch on the equipment, tune and identify the appropriate station and use bearing and or range information to assist with navigation as well as tracking to and from the station.

Limitations on the use of the equipment should be demonstrated and use made of simulator training for these exercises.

AIR TRAFFIC CONTROL PROCEDURES

During all dual navigation exercises insist on a high standard of radio procedure and strict observance of ATC clearances and requirements. Point out that no matter how skillfully the student can fly or map read, a student's knowledge is quite incomplete if unable to safely and confidently abide by all airspace requirements.



17 INSTRUMENT FLYING

AIM

To teach the student to fly the aeroplane accurately without external visual reference.

INSTRUCTIONAL GUIDE

Pilots tend to fly by reference to the natural horizon. Instrument flying is an extension of this technique. In instrument flying the natural horizon, and the attitude of the aeroplane with reference to that horizon, must be visualized through the flight instruments. This principle of attitude interpretation which must be emphasized by the instructor to show, that by interpreting the aeroplane's attitude through the flight instruments, the same principles apply whether conditions are visual or otherwise.

The student must interpret the aeroplane's attitude and then, as in visual flight, change the attitude until the desired performance is obtained. The controls are used in the normal way, but the aeroplane's attitude must be interpreted as a whole instead of 'chasing' the individual pointers.

Ensure the student does not have a grip on the controls that is too tight, thus preventing any 'feel' for what the aeroplane is doing.

If at all possible, given the many legal restrictions, expose the student to some actual instrument flying conditions

Essential training considerations are discussed under the following headings:

- Flight principles
- Demonstrations in the clear
- Sensory Illusions
- Cross reference
- Relationship between Control, Attitude,
- Power and Performance
- Control technique

Flight Principles. The student must have a good basic knowledge of the forces involved in flight. The effects of inertia particularly must be appreciated. Inertia causes a delay in response to any control change and must be considered when interpreting pitch attitude through the pressure instruments. For example, on entering a climb from level flight the change in nose position does not reflect itself immediately in the indications of the pressure instruments. These instruments will eventually 'catch up' thus indicating the new nose position.

Demonstrations in the Clear. In learning and teaching instrument flying it is desirable that all practices be performed by reference to the natural horizon before being repeated on instruments alone. Attitude interpretation through the instruments and the relationship of attitude to performance, are all appreciated more readily by noting the instrument indications while the demonstration is being done in the clear.

Sensory Illusions. To avoid any confusion which may be caused by physiological sensations, the pilot must be aware of the sensations likely to be experienced in instrument flight so that they may be recognized and disregarded.

The unusual sensations experienced by a pilot when flying on instruments are often very strong, completely misleading and confusing. Even very experienced instrument pilots must at times make very conscious efforts to disregard these sensations. Often a pilot's senses will insist that the aeroplane is doing quite the opposite to what is in fact the case. The pilot might believe that the aeroplane is turning when in fact it is straight and level, or that the aeroplane is upside down when it is doing a gentle turn. Students must be fully briefed to ignore these sensations and believe the instrument indications.



Cross Reference. The student must learn to pay attention to all instruments and not concentrate on any one, so that at any moment the information is portrayed as a whole and not confined to a certain aspect of the attitude. Lack of cross reference and concentration on only one or two instruments is a serious failing and only by constant practice can the speed of cross reference be increased.

Relationship between Control, Attitude, Power and Performance. The student must know how to control the aeroplane's attitude in visual conditions, and from experience in controlling its performance, know the relationship of attitude to airspeed, height and direction.

Of special significances is that for a given aeroplane weight and configuration a given attitude combined with a given power setting will always result in the same flight path relative to the air. This flight path or performance, may be straight, turning, level, climbing or descending, but so long as the appropriate attitude and power setting remain unaltered the performance will be unaltered. Any change in attitude and/or power setting will result in a change of performance, i.e. the airspeed, rate of climb or descent, rate of turn, or all three may change.

In teaching instrument flying, the instructor must develop in the student a keen appreciation of the importance of time. For objective precision flight there are three main requirements -direction, airspeed and time. It is important to appreciate the time factor for, as the student progresses to more advanced aeroplanes and procedures, the pilot's speed of instrument coverage must increase. The instructor must cultivate in the student the habit of including time in instrument coverage, and for this reason the clock should be positioned near, or be part of the instrument panel.

Control Technique. Every instrument flight manoeuvre is the result of correlation of the picture shown by the instruments and the control movements. A change from one flight manoeuvre to another involves the following control sequence:

- Visualizing the new desired flight performance
- Selecting attitude and power appropriate to the new desired performance
- Waiting until the aeroplane settles down to the new performance
- Correcting and adjusting attitude and power until the new performance equals the desired performance
- Trimming and balancing the flight

In brief terms this can be stated as CHANGE - CHECK - HOLD - ADJUST - TRIM. This is the control technique that should be followed in making alterations of performance in visual flight and is nothing more than an application of the basic flight principles taught in early training.

There is an alternate and valid view, slightly different to the above which is held by some experienced instructors i.e.:

- Select what is believed to be the correct attitude
- Hold this attitude
- Trim to this attitude
- If the attitude is incorrect repeat the first three steps

PRE-FLIGHT BRIEFING CONSIDERATIONS

The student must have a good appreciation of the points discussed in the Instructional Guide.

Attitude is the position of an aeroplane's longitudinal and lateral axes relative to the natural horizon, and the student must be briefed on how pitch and bank attitude are visualized through the flight instruments and the limitations of these instruments.

INSTRUMENTS - INDICATING PITCH ATTITUDE

The four instruments which show pitch attitude or nose position are:

Attitude indicator. This should be regarded as the master instrument since the position of the index aeroplane relative to the horizon bar gives a direct picture of the aeroplane's attitude in pitch within the limitations of the instrument. The limitation in pitch (before the instrument topples) in a light training aeroplane is normally at least 60°.

If the index aeroplane is adjustable, the student must be aware of how to set it relative to the horizon bar in straight and level flight.

The use of the caging mechanism, if fitted, must also be explained to the student.

Altimeter. The altimeter is used not only to determine height, but also to indicate pitch attitude. While constant height is being maintained, the nose position is correct for level flight for that power. Increasing or decreasing height indicates a nose position that is respectively too high or too low.



Airspeed Indicator. The student must understand that this instrument may also be used to indicate nose position. If showing the desired airspeed, the instrument indicates that the nose position is correct for the power being used. Indication of increasing or too high an airspeed, or decreasing or too low an airspeed, shows a nose position that is respectively too low or too high. When cross referred with the altimeter, the ASI will show the correct nose position for level flight at the power being used. The student must be briefed that owing to inertia an aeroplane takes time to change speed and therefore, the airspeed must be held constant for some time before it can be regarded as an indication of the attitude of the aeroplane. If this is not stressed the student will 'hunt' (or chase) the airspeed, resulting in an undesirable fluctuation in airspeed.

Vertical Speed Indicator. In level flight the instrument indicates zero. Any sustained departure from zero therefore, shows that the nose position is too high or too low for level flight. It must be understood that while it indicates fairly accurately steady rates of climb or descent it gives no direct indication of attitude. It does give very useful confirmation of other instrument indications and also provides a convenient check on required rates of climb or descent.

INSTRUMENTS - INDICATING BANK ATTITUDE

The three instruments which show bank attitude or wing position are:

Attitude Indicator. As with pitch attitude this instrument should be regarded as the master instrument, since the position of the index aeroplane relative to the horizon bar and the position of the pointer on the angle of bank scale, together give a direct picture of the aeroplane's attitude in bank or roll within the limitations of the instrument. The limitation in roll (before the instrument topples) is normally at least 90°.

Turn and Balance Indicator. This instrument shows the rate and direction of turn. Therefore, in balanced flight any indication of turning means that the aeroplane is banked, and a constant zero reading means that the wings are level.

Direction Indicator. If the flight is balanced a constant heading indicates that the wings are level. If the heading is changing then the wings are banked in the direction of the turn. It is important to stress the limitations of this instrument which are normally at least 55° in both the pitching and rolling planes.

Brief the student that if the type of direction indicator in use is not slaved to magnetic north, it will need to be re-set with the magnetic compass at regular intervals and after aerobatic flight.

Having ensured that the student has been thoroughly briefed on the points raised in the Instructional Guide and on the principle of attitude interpretation, the instructor should now brief the student on the methods and techniques to be used in the following air exercises.

INSTRUMENT— INDICATING YAW

Turn and balance indicator. The aeroplane is out-of-balance if the (balance) ball is not centered. An out-of-balance indication is not indicating yaw if the heading is constant.

AIR EXERCISE

- Attitude - pitch
- Attitude - bank and direction
- Attitude - effect of changing power
- Climbing and descending
- Turning
- Climbing and descending turns
- Steep turns
- Recovery from unusual attitudes

ATTITUDE—PITCH

This demonstration will teach the student to interpret correctly the indications of all instruments which show the aeroplane's attitude and its movements in the pitching plane.

Because it is impossible to discuss more than one thing at a time, in the following paragraphs each instrument must be introduced in turn. Bear in mind that the ultimate aim is continual cross-reference of all instruments.

This exercise, though apparently very simple, must not be cut short in any way. It forms the foundation for instrument interpretation of all manoeuvres involving changes of attitude in the pitching plane.

Throughout this demonstration maintain a constant power setting, which is usually the cruise power setting.



IN THE CLEAR

Attitude Indicator (AI). Settle the aeroplane in straight and level cruise flight and then raise and lower the nose above and below the horizon. Point out to the student that the instrument immediately shows the change in pitch attitude, but owing to its small size normal changes in attitude are shown as quite small movements of the index aeroplane relative to the horizon bar. Point out also that on returning the aeroplane to its straight and level position in relation to the natural horizon the instrument also reflects the aeroplane's actual attitude.

Airspeed Indicator (ASI). From level flight raise or lower the nose position using the 'Change - Check - Hold -Trim' technique described in the Instructional Guide, i.e. change the attitude to start the nose moving to the desired position, check when the desired position is thought to be reached, then hold it and trim the aeroplane. Point out that whilst the airspeed starts to change as soon as the nose position is changed, it takes time to settle at a new figure owing to the aeroplane's inertia. Show that if the nose position is held constant, the airspeed settles at a constant new figure, i.e. constant new performance for a new attitude at that power. Demonstrate, by changing the pitch attitude at varying rates, how the rate of change of airspeed is proportional to the rate of change of attitude. Point out that in order to change the airspeed, the student should always anticipate the required airspeed slightly, and should then always wait for the airspeed to settle after the change in attitude. Ensure that the student understands that any change from a constant airspeed indicates a change in pitch attitude.

AI and ASI. Now demonstrate some simple cross-reference between these two instruments. Firstly, raise the nose relative to the natural horizon into an attitude which will result in an appreciable fall in airspeed. Point out that the change in attitude is confirmed immediately by the AI. Show that the airspeed starts to decrease and after a short time will remain at a constant figure. Repeat for a nose down attitude. Ensure that the student appreciates that while the AI gives an immediate indication of pitch attitude the same information can be interpreted through the ASI.

Altimeter. From level flight demonstrate that by raising and lowering the nose that the altimeter indicates a change in pitch attitude. Point out that just as constant airspeed means constant attitude, so constant height means constant attitude. Demonstrate changes of pitch attitude at different rates pointing out the altimeter's response. Point out that the instrument possesses an inherent lag error during rapid changes, this being particularly applicable to high performance aeroplanes.

AI, ASI, and Altimeter. Bring the student's attention to all three instruments. Change the attitude as before showing that the change is immediately apparent on the AI, and that the change is confirmed by the indications of the ASI and altimeter.

Vertical Speed Indicator (VSI). Stress that this instrument gives accurate indications only when the aeroplane is in level flight or in a steady climb or descent. Demonstrate by raising or lowering the nose, that whilst the indications of the instrument may not be very accurate, it does have great value in showing a trend thus indicating a change in pitch attitude. Point out that in turbulent conditions its indications are likely to be erratic. Some modern VSIs over read when 'g' loadings are applied.

AI, ASI, Altimeter and VSI. Now demonstrate that by cross-reference to all these instruments a complete picture of pitch attitude is available. Fly level and show by reference to the natural horizon that a constant attitude and performance means constant instrument indications on all these instruments. Now raise the nose. Point out that the AI will show the change in attitude directly; the ASI will show a decrease in airspeed proportional to the rate of change of attitude until a steady performance is reached for the new attitude; the altimeter will show a change in height and thus a change in attitude; the VSI will also show a change in attitude.



THROUGH INSTRUMENTS

When the student appears to be cross-referring to all the pitch attitude instruments satisfactorily and has grasped the fundamentals of pitch attitude instrument interpretation, carry out the following exercises involving pitch changes only.

Full Panel. Have the student cross-refer to all the pitch attitude instruments using the AI as the master instrument.

Do not worry the student unduly about keeping straight at this time. When the student is keeping the pitch attitude reasonably constant, have the student decrease the airspeed by some 20 knots or so. Point out that this change is made by altering the pitch attitude by reference to the AI, holding the new attitude until a constant speed is reached, and then adjusting the attitude in small increments until the desired speed is attained. Point out that in making these final small adjustments the student must remember the effects of inertia and must wait for performance of the aeroplane, i.e. airspeed, to give a steady indication before changing the attitude. Repeat the exercise for a slightly nose-down attitude to give an airspeed of some 20 to 30 knots more than cruise flight.

Note: There is a view held by some instructors that limited panel training should not be introduced until the student is proficient with all aspects of 'full panel' instrument flying.

Limited Panel. When the student is reasonably proficient on the full panel, carry out the same exercise with one or more of the four pitch attitude indicators covered. Cover the AI first and allow the student to practice pitch attitude interpretation through the indirect indicators - ASI, Altimeter and VSI. Ensure that the student employs the 'Change - Check - Hold - Trim - Adjust' technique. Stress that you must cross-refer to all available instruments. The aim should be to change the attitude in pitch and change from one constant airspeed to another. Repeat the exercise with other pitch attitude instruments covered.

ATTITUDE - BANK AND DIRECTION

This demonstration will teach the student to interpret correctly the indications of all instruments which show the aeroplane's attitude and its movements in the rolling and yawing planes.

Remember that, although the instruments are dealt with individually, for instrument flight they must be continually cross-referred.

Here again any tendency to cut short this relatively simple exercise must be resisted.

As before, maintain a constant power setting throughout the demonstration.

IN THE CLEAR

Attitude Indicator. From straight and level flight bank the aeroplane to the natural horizon. Point out that the instrument gives an immediate and direct indication of the position of the wings relative to the natural horizon. Stress the importance of the fact point out that the angle of bank is shown in the correct sense by the angle of the index aeroplane to instrument horizon bar and by the pointer which moves over the angle of bank scale. Show that when the aeroplane banks it turns in the direction of bank. Stress that in balanced flight bank and turn are inseparable and any change in lateral wing position means a change in direction.

Turn and Balance Indicator. Fly straight and level by reference to the natural horizon, point out that if the aeroplane is correctly trimmed and flight is balanced the instrument shows zero rate of turn and no slip or skid. Stress that this indicates that the wings are level. Bank the aeroplane and demonstrate that when the aeroplane starts to turn the turn needle shows a turn in the direction of bank. Demonstrate that if the bank is increased the rate of turn is increased. By decreasing the bank show that the rate of turn decreases until when the wings are level it returns to zero.



Before going on to practice cross-reference of those instruments which indicate bank attitude, make sure that the student is aware of the correct co-ordination of the controls with the turn and balance indicator. Point out that as an indication of turn means that the aeroplane is banked, the aileron is the control which must be used to level the wings. Let the student be convinced of this visually by applying bank and then returning to level flight by reference to the turn needle and use of ailerons. On the other hand the balance indicator, whether it be of the needle or ball type, is controlled by rudder. Demonstrate to the student that any sustained displacement of the balance indicator can be corrected by applying rudder in the same direction as the balance indicator displacement. Alternatively it may mean easing pressure applied by the other foot i.e. when leveling off from a climb. Give the student plenty of practice at maintaining level balanced flight through this instrument before proceeding further. Point out that in turbulence there may be considerable oscillation of the indicators. In these conditions the indicators must not be chased but the oscillations should be kept roughly equal on either side of the zero. This will result in the wings remaining level.

Direction Indicator. This instrument provides another indication of bank attitude. From level flight bank the aeroplane and point out that the resulting turn is shown as a change in direction. Show that a return to level balanced flight results in a constant heading. It can therefore be stated that a constant heading signifies a level wing position and any sustained movement of the DI implies bank - within the instrument's limitations.

AI, DI, and Turn and Balance Indicator. Before proceeding to instrument flight practice, have the student try simple cross-reference exercises utilizing all the wing position indicators. Have the student fly straight and level, noting how the AI, DI and Turn and Balance Indicator all show level balanced flight. Then have the student bank the aeroplane and see how all three instruments give an indication in the correct sense of the change of attitude.

THROUGH INSTRUMENTS

Now carry out the following exercises with the student under simulated instrument conditions.

Full Panel. The aim now is to interpret attitude through all instruments, in all three planes of movement. Have the student settle down to cruise flight and then, by using all the instruments in constant cross-reference, maintain a steady attitude for level flight in a given direction. When the student can do this satisfactorily, have the aeroplane banked in both directions and returned to the same direction of straight and level flight. Then have the student change pitch attitude whilst remaining directionally straight.

Limited Panel. Repeat the exercise with one or more instruments covered. First cover the AI and have the student maintain constant height, airspeed and direction by cross-reference of the remaining instruments. Then cover or cage the DI and have the student practice keeping the wings level through the turn and balance indicator alone, keeping a check on direction by reference to the compass. Then nominate a new airspeed and have the student change the pitch attitude to achieve and maintain this airspeed at the same power setting while keeping as steady a direction as possible. The ultimate aim is for the student to have confidence in controlling pitch and bank attitude with any of the instruments out of action.

ATTITUDE - EFFECT OF CHANGING POWER

During this sequence the student will learn to interpret the instrument indications of changes of attitude due to power variation, and to appreciate the importance of correct trimming.

During this sequence the instructor must watch for constant instrument coverage and full cross-reference of all instruments. This is the last sequence dealing solely with changes of attitude. In future sequences the interpretation of attitude will be assumed.

During this sequence the student should aim to keep a steady direction throughout. The instructor should insist on reasonably precise performance in height, airspeed and direction, and therefore accurate instrument flight must be the objective from now on.



IN THE CLEAR

Change of Attitude and Airspeed with Change of Power at a Constant Height. While in straight and level flight change the power setting and point out how with increasing power the nose tends to rise, and with decreasing power tends to drop. Thus the attitude is changed without movement of the elevator control surfaces. Return to straight and level flight and increase power. At the same time lower the nose slightly to maintain constant height by reference to the altimeter, and point out that the change of attitude is shown directly by the attitude indicator and indirectly by an increase of speed on the ASI. Point out that although speed is increasing, because of inertia it takes time for the aeroplane to steady at a new airspeed. Point out that it is necessary to re-trim to relieve control pressures. Now reduce the power to below the straight and level figure and demonstrate that to keep constant height the nose must be raised until a new constant airspeed is reached. Again point out that because of inertia this takes time. Show that re-trimming is essential. Allow the student to practice changing power at a constant height until competent at cross checking the altimeter and AI as indicators of the correct nose position.

Change of Attitude and Height with Change of Power at Constant Airspeed. Introduce this sequence from straight and level flight. Increase the power and show that to keep the airspeed constant the attitude must be changed. Point out that the change in attitude must be made fairly slowly and show that there is an increase in height. Stress that re-trimming is necessary. Return to level flight and reduce power to below cruising, pointing out that this time it is necessary to lower the nose to keep the airspeed constant. Stress the re-trimming when the aeroplane has settled down to its new performance. Practice changing power at constant airspeed until the student is competent at cross checking the ASI with the AI as indicators of the correct nose position. Stress that any necessary adjustment of attitude should be small, and a small interval of time must elapse before the aeroplane finally settles down to its new performance.

Effect on Directional Control of Changing Power.

Although the student should be aware of this effect from an early lesson it is as well to re-emphasize it. Make considerable changes in power setting and point out that any tendency to bank and/or yaw can be readily 'seen' through the AI, DI, and Turn and Balance Indicator. Stress that the student must be prepared to correct for this effect whenever power is altered.

THROUGH INSTRUMENTS:

FULL PANEL

Changing Airspeed at Constant Height. Have the student settle the aeroplane in straight and level flight before increasing power and use all the instruments to settle down at a new constant airspeed while maintaining a constant height. Point out that this should be done by changing the attitude by direct reference to the AI, confirming the correct nose position by reference to the altimeter and then making small adjustments as necessary. Ensure that the student re-trims to eliminate control pressures. Repeat the exercise for a decrease in power.

Changing Power at Constant Airspeed. Again from straight and level flight have the student increase power and change the attitude to maintain a constant airspeed. Point out use of the AI as the direct indicator of attitude and the ASI to confirm the correct nose position. Do not allow the student to 'chase' the airspeed. Point out the need for smooth control movements and allow for inertia to all instruments. effects. Ensure that the student is cross-referring

LIMITED PANEL

Now cover one or more of the instruments and repeat the above sequences until the student is able to control the aeroplane through changes of power with any of the instruments out of action. Point out that without the aid of the attitude indicator, inertia effects appear to be even more marked. Particularly during sequences on the limited panel the 'Change - Check - Hold - Trim - Adjust' technique must be used and the tendency to chase needles must be avoided.

CLIMBING AND DESCENDING

During this demonstration the student will learn how to interpret the instrument indications during climbing and descending, entering a climb or descent, and of resuming level flight.

A constant direction should be maintained during each sequence and aim for a fairly high degree of precision.



IN THE CLEAR

Initiating a Climb. From straight and level flight increase the power to the climbing figure and raise the nose to the correct attitude. Point out that the new attitude is shown directly by the AI, that the airspeed begins to decrease, that the altimeter shows a gain in height and that the VSI shows a rate of climb. Wait until the airspeed has settled down, emphasize this waiting period, and then make any minor adjustments necessary to obtain the correct attitude for the climbing power selected. Demonstrate that the aeroplane must be re-trimmed. Maintain steady climbing flight by constant cross-reference to all instruments and point out that, although all instruments provide an indication of the aeroplane's attitude, the ASI is the instrument that confirms the correct attitude for climbing as shown by the AI.

Leveling off from a Climb. The student must understand that to level off at any desired height, the aeroplane's nose position must be lowered towards the cruising flight position before that height is reached, the amount of 'lead' depending on the rate of climb. From a climb demonstrate and point out to the student that the technique is to select a particular height and slowly start changing attitude before reaching that height, about 10% of the rate of climb, in advance of the selected height. Point out that to maintain constant height while leveling off, the altimeter must be referred to as speed is gained to ensure that the correct nose position is being assumed. Reduce power as cruising speed is approached and then point out the small adjustments of power and attitude necessary to obtain the required level flight performance. Show that all instruments give an indication of attitude but the **altimeter** is the instrument which confirms the correctness of attitude as shown by the AI when leveling off. Point out that it is necessary to make allowance for the inherent lag of the VSI when leveling off.

Climbing and Leveling Off Without Using the AI. Repeat the above sequences with the AI covered and, drawing the student's attention to the natural horizon, point out that:

- (a) When climbing, the ASI gives the most direct indication of pitch attitude
- (b) When leveling off, the altimeter gives the most direct indication of pitch attitude

In both cases it should be stressed that due allowance must be made for the effects of the aeroplane's inertia.

Initiating a Descent. Carry out this demonstration from level flight, reduce power and, by maintaining the aeroplane's attitude, allow the airspeed to fall until it reaches that desired for the descent.

Then lower the nose position and observe how the ASI confirms the attitude of descent that is indicated on the AI. Re-trim and ensure that flight is balanced. Demonstrate that to achieve any desired rate of descent the power and attitude must be adjusted, i.e. to increase the rate of descent reduce power and lower the nose as necessary to maintain airspeed; to decrease the rate of descent increase power and raise the nose as necessary to maintain airspeed. In both cases point out that the rate of descent is checked by reference to the VSI or altimeter and clock.

Leveling Off from a Descent. Point out that as when leveling off from a climb, to level off at any desired height the aeroplane's attitude must be changed before that height is reached. The amount of anticipation depends largely on the rate of descent but is usually 10% of the rate of descent. While descending select a particular height and before reaching it increase power to the setting for cruising flight and slowly change attitude to attain level flight at the selected height. Note that in this case it is the **altimeter** that confirms the correct level flight position as shown by the AI. Demonstrate that it is necessary to wait for a steady performance to be reached and then adjust power and attitude to give the required airspeed at the required height and re-trim.

Descending and Leveling Off Without Using the AI.

Repeat the above sequences with the AI covered and point out by reference to the natural horizon that:

- (a) When **descending**, the **ASI** gives the most direct indication of the correct pitch attitude
- (b) When **levelling off**, the **altimeter** gives the most direct indication of the correct pitch attitude

In both cases an allowance for inertia must be made when making attitude changes.



THROUGH INSTRUMENTS

If the student has practiced the previous climbing and descending sequences in the clear and is familiar with the instrument indications, there should be no difficulty in practicing the exercises solely on instruments. Give the student practice on full and limited panel in climbs and descents at various rates. Use the clock and altimeter to confirm the indications of the VSI and ensure that the student is competent at leveling off accurately at a desired height. Emphasize that the VSI can only be relied upon to give an accurate rate of climb or descent if the vertical speed of the aeroplane is steady.

TURNING

During this demonstration the student will learn how to interpret the instrument indications during turns and to make precision turns on to given headings.

Precision sequences should be introduced at this stage. The element of time is also brought into the instrument coverage. A time piece is very important in precision instrument flight, and should now be regarded as part of the flight panel.

A constant height should be aimed for throughout the following sequences.

IN THE CLEAR

Turning Flight. Stress the three essential elements of an accurate turn. These are:

- a constant amount of bank
- balanced flight i.e. correct use of rudder
- the correct nose position to maintain altitude.

The first is achieved by co-coordinating aileron and rudder and the third by the use of elevator. Thus for turning flight the use of all controls must be co-coordinated and the attitude interpreted from all instruments.

From normal straight and level flight enter a turn and demonstrate that any faulty co-ordination of aileron and rudder (i.e. incorrect balance) is shown as a slip or a skid on the balance indicator*. Point out that the AI gives a true indication of the aeroplane's attitude in pitch and bank and that this can be checked against the indications of the altimeter, ASI, VSI, and turn needle. *Demonstrate that the amount of rudder required during the entry to and exit from the turn is dependent on the rate of application of aileron. When the turn is stabilized rudder is used simply

to balance any residual yaw. On recovering from the turn, point out that all the instruments will again indicate the correct attitude for level flight. Have the student practice entering, sustaining, and recovering from turns of 30° angle of bank until satisfied with the ability to co-ordinate control movements with the interpretation of attitude from the full panel.

Precision Turns at a Definite Rate on to a Definite

Heading. Demonstrate that the aeroplane does not come out of a turn immediately action is taken to reduce the angle of bank. (Even though this fact should have been thoroughly demonstrated during the first lesson on turning.)

Point out that the 'lead' or anticipation of the new heading is achieved by commencing the roll out at about half the bank angle e.g. for a 30 degree banked turn commence the roll out about 15 degrees before the nominated heading.

Ensure that the student is aware of the direct relationship between true airspeed and angle of bank to rate of turn. As airspeed increases bank must increase for any given rate of turn. For a standard rate one turn (3° per second) an approximate angle of bank may be obtained by adding 7 to the first two digits of the true airspeed in knots, e.g., a rate one turn at 95KT requires $9 + 7 = 16^\circ$ angle of bank.

The rule of thumb is for balanced flight only.

Have the student practice precision turns at rate one onto nominated headings. When the student has grasped the principle of turning by angle of bank, rate of turn and time have the student turn on to definite headings with the DI covered or caged, checking on the accuracy of the turn by cross-reference to the compass.

Precision Turns Without the AI or DI. Before starting turning under instrument conditions, have the student try a few turns in the clear with the AI and DI covered. In these conditions (which would be expected with the failure of an engine driven vacuum pump) the angle of bank (about rate one or less) can be interpreted from the turn and balance indicator and the nose position from the altimeter, ASI and VSI. Watch for any tendency to over bank. Point out that the student must allow for compass error. Ensure that the student always waits for the compass needle to settle down before correcting any errors in heading.

A good rule of thumb for small heading changes is to use a bank angle of no more than the number of degrees to be turned through divided by two.



THROUGH INSTRUMENTS:

Full Panel. If the student has had little difficulty with the preceding sequences there should be little difficulty in going ahead with turns and then precision turns under instrument conditions. Have the student first practice turns on to definite headings. Ensure the student is cross-referring to all instruments, pointing out that this is essential to maintain a precise performance. When the student is fairly competent at this introduce timed turns at rate one through varying numbers of degrees.

Limited Panel. With the student flying the aeroplane repeat all the fore-going exercises with firstly the AI and then the AI and DI covered. Stress that control movements must be small but firm, and that constant cross-reference to all the available instruments must be maintained. Watch for any tendency to chase the compass. It is most important for the student to understand that on completing the turn it is a must to fly straight and level and wait for the compass to settle. The student must then estimate the amount of error, make a correction and then wait again for a steady indication of heading.

CLIMBING AND DESCENDING TURNS

The student should now learn to interpret the instrument indications during climbing and descending turns, and to make these turns at specific rates through the instrument indications.

Having reached this stage do not let the student be satisfied with being 'just good enough'. The student should by now be able to fly within the limits of $\pm 200\text{FT}$, $\pm 5^\circ$ and $\pm 10\text{KT}$.

It is even more important in these sequences to cross-refer to all instruments continually to attain the correct airspeed, vertical rate and direction, and confirm the rates of climb and descent by timing and altimeter.

IN THE CLEAR

Climbing Turn from a Climb. Set up normal climbing flight, roll into a climbing turn and point out that the AI indicates the correct attitude in pitch and bank relative to the natural horizon, while all other instruments confirm that the aeroplane is climbing and turning. Check the angle of bank for the required rate of turn and ensure that flight is balanced. Point out that as in the straight climb it is the ASI which confirms the correct pitch attitude, and that the turn indicator confirms the bank attitude. Have the student practice climbing turns on to definite headings adjusting attitude as necessary to keep the desired performance. Repeat the sequence with some of the instruments covered and ensure that the student is able to interpret the aeroplane's attitude correctly from the instruments which give an indirect indication of attitude.

Climbing Turn from Level Flight. This is a combination of the climbing and turning exercises. From level flight increase power and roll the aeroplane into a turn, at the same time raising the nose to the approximate position for the climb. Point out the angle of bank for the required rate of turn and adjust as necessary. Demonstrate that as the airspeed approaches climbing speed it may be necessary to adjust the angle of bank to maintain a constant rate of turn and that constant cross-reference to the ASI is necessary in adjusting pitch attitude. Practice leveling off from the turn on a specific heading and height. Have the student repeat these sequences with the AI and DI covered, pointing out with reference to the natural horizon how the attitude can be interpreted, although direct instrument attitude indications are not available.

Descending Turn from a Descent. From a normal descent roll into a turn and point out that, as with a climbing turn, the correct pitch attitude relative to the natural horizon is confirmed by cross-checking the ASI and the AI, and the correct bank attitude by cross-checking the rate of turn indicator with the AI. Have the student practice descending turns on to specific headings, stressing that he should interpret the instrument indications, adjust the attitude as necessary and then by reference to the natural horizon verify the correctness of his interpretations. Cover up the AI and DI and allow the student to interpret the aeroplane's attitude as before from the remote indicating instruments.

Descending Turn from Level Flight. Point out to the student that it is necessary to co-ordinate the descending and turning exercises in the same way as initiating a climbing turn from level flight. Again it is the ASI which confirms the pitch attitude.



Precision Climbing and Descending Turns. Before proceeding to the practice of climbing and descending turns through instruments alone, have the student practice co-coordinating turns through a specific number of degrees while gaining or losing a specific amount of height, e.g. a rate one turn through 360° while climbing or descending 1,000FT at 500 feet per minute over a time interval of two minutes. This will ensure that:

- (a) the student understands the technique of regulating vertical speed with power while making changes in attitude to maintain a constant airspeed; and
- (b) the student can maintain constant cross-reference to all instruments depicting attitude, power, performance and time.

THROUGH INSTRUMENTS

The student should practice all the foregoing manoeuvres through instruments alone. On full and limited panel practice climbing and descending turns from steady climbs, descents and level flight and turns at specific vertical rates.

STEEP TURNS

It is rarely necessary to turn at large angles of bank during instrument flight. However, the increasing speeds of modern aeroplanes are demanding quite high angles of bank even for moderate rate turns. This sequence is of great benefit as an exercise in co-ordination, as it requires rapid and effective cross-reference and a high standard of attitude interpretation to achieve even moderate precision.

In practicing these turns the student should aim for a sustained turn at an angle of bank of 45°.

IN THE CLEAR

From level flight, roll slowly into a turn with about 35° angle of bank, and point out the instrument indications which show the aeroplane's attitude in pitch and bank, the balance and rate of turn and the gain or loss in height and airspeed. Hold the turn and point out how the nose position relative to the natural horizon is slightly higher than for level flight, and is confirmed by the AI. Also point out that back pressure may be required on the controls to prevent the nose from dropping. Now increase the bank, pointing out that more power will be needed to maintain height and airspeed again note the nose position and increased back pressure on the controls. Roll out of the

turn reducing power as necessary, and stress how the lower nose position for level flight is confirmed by the AI. The altimeter will confirm the need to lower the nose, otherwise a gain in height will be experienced. When the student has practiced this sufficiently, demonstrate the errors which can occur.

Roll into a steep turn but allow the nose to drop. Point out the increase in airspeed and loss of height. Demonstrate that if the attitude is not checked immediately, a spiral descent develops. When this has developed, point out that recovery by elevators alone is difficult and may even be impossible. Show that with a reduction in angle of bank by reference to the AI the nose can easily be brought back to its correct position.

Allow the student to practice steep turns, pointing out that even in the clear with all instruments available you are compelled to refer to his altimeter, ASI and balance indicator for accurate assessment of the quality of the turn. The same is true for a turn by instruments alone and any change of attitude must be corrected immediately it becomes apparent.

THROUGH INSTRUMENTS

Full Panel. Have the student roll into the turn slowly and smoothly, to an angle of bank of about 45°.

Ensure cross-referring to all instruments and making adjustments to attitude even as the turn is entered. Prompt the student to think in terms of attitude and to make control corrections for errors exactly as would be done in a visual turn. Stress particularly that to raise the nose position, quite a heavy back pressure is required, while to lower it all that is necessary is to relax the back pressure slightly. During the recovery, point out the necessity to prevent the aeroplane climbing. During this exercise the physiological sensations experienced by the student may well be much stronger than in previous exercises. The student must still ignore these sensations and trust the instruments implicitly.

Limited Panel. Steep turns with the AI and DI covered must be approached gradually. Start with a small rate of turn, gradually increasing this as confidence and skill are gained. The most common failing is to allow the nose to go down, together with a tendency to over-bank.



OTHER USEFUL COORDINATION EXERCISES – FULL OR LIMITED PANEL

- 1 From straight and level flight commence a rate one level turn (left or right) and, whilst maintaining height, reduce the IAS to a nominated speed about 10KT above the stall speed. When that speed is reached reverse the direction of the turn and accelerate the aeroplane back to the original IAS and roll out of the turn when the speed is reached. Repeat or continue for as long as required.
- 2 From straight and level flight commence a climbing turn (left or right). Each time the aeroplane passes North or South (or any other chosen opposite headings) reverse the direction of the turn. When the aeroplane has climbed through 1000FT commence a descending turn (30° angle of bank FP, rate one turn LP), still reversing heading passing North or South and recommence the climb at the start altitude. Repeat or continue as long as required.

RECOVERY FROM UNUSUAL ATTITUDES

The aim in this sequence is to recognize any unusual attitude of the aeroplane by interpretation of the instrument indications and to recover from such attitudes in the minimum time with the minimum loss of height.

Just as steep turns by instruments called for correct and rapid attitude interpretation, recognition and precise recovery from unusual attitudes demand immediate assessment of attitude from all available instruments.

The physiological sensations experienced in these sequences are usually most disconcerting. The instruments are invariably more reliable and the student must learn to ignore these sensations and believe the instruments.

These sequences must be practiced. However, the more severe attitudes cannot be practiced in non-aerobatic aeroplanes. Normally a pilot will not enter unusual attitudes while in instrument flight. They can occur however, through poor instrument interpretation or faulty technique. Severe turbulence or wake turbulence may cause an unusual attitude to be assumed.

For simplicity in presentation the sequences are divided into two general types of unusual attitude:

- (a) Those characterized by a low airspeed (two recovery techniques)
- (b) Those characterized by a high airspeed

IN THE CLEAR:

UNUSUAL ATTITUDES AT LOW AIRSPEEDS

Full Panel. From normal level flight raise the nose position to an unusually high attitude, at the same time applying a steep angle of bank. Point out the instrument indications with reference to the natural horizon. Stress the rapid decrease in airspeed then show that by returning the index aeroplane of the AI to the horizon bar, level flight is easily regained (i.e. a simultaneous 'push forward' [elevator] and 'roll wings level' [aileron]). Point out that the airspeed may still be low even when level flight has been gained and that it builds up slowly to the normal cruising figure.

Limited Panel. Cage (or cover) the DI and AI. Point out now that pitch attitude is determined by the ASI and altimeter; the steep pitch attitude is shown by a rapid decrease in airspeed and rapid increase in height. Now use the controls to return the aeroplane to normal level flight attitude and compare the indications of the ASI with the aeroplane's attitude relative to the natural horizon. Stress that, **at the moment the airspeed ceases to reduce, the nose position is approximately that for level flight. (Similarly, the approximate level attitude is also obtained when the altimeter 'stops moving')**

Before continuing further give the student plenty of practice at 'finding the horizon' through the ASI and then holding level flight through the altimeter while the airspeed slowly builds up to normal.

Again from level flight, put the aeroplane into a steep nose-up attitude and apply a steep angle of bank. Point out that the turn indicator shows which wing is lowered. To regain level flight, the aeroplane must be rolled level until the turn indicator returns to the centre. In an extreme wing low situation the ailerons need to be centralized when the turn needle 'leaves the stop'. The nose position is adjusted as before and the rudder is used to control slip or skid. Point out that as a further aid to regaining a level attitude, the student should, if the DI is toppled and spinning, cage and uncage that instrument.

To summarize:

- (a) The regaining of laterally level is of primary importance, as forward pressure on the controls when the aeroplane is on its side may aggravate the situation
- (b) Increase power if the attitude is steep and the speed is very low – see following explanation
- (c) Cage and uncage the DI when the aeroplane is roughly in level flight to assist in maintaining lateral level



LIGHT AEROPLANE - STANDARD NOSE HIGH RECOVERY TECHNIQUE

SIMULTANEOUSLY

- Airspeed rapidly approaching or below maximum angle climb speed – APPLY FULL POWER (Otherwise leave power as is.)
- ROLL WINGS LEVEL
- EASE FORWARD ON CONTROL COLUMN TO LEVEL ATTITUDE

LIGHT AEROPLANE – STANDARD NOSE VERTICAL RECOVERY TECHNIQUE

Flight controls ineffective and IAS near zero:

- Close throttle
- Tight grip on control column, feet firmly on rudder pedals to prevent possible control snatch during tail slide
- Nose pitches down
- Level wings and ease out of dive

Stalling and Recovering. When the student is competent at recognizing and correcting low speed, unusual attitudes take the low speed situation to the extreme, i.e. to the stall, pointing out the instrument indications. Demonstrate this by reducing power and raising the nose. As the aeroplane approaches the stall, point out how the indications of increasing height change, until at the point of stall a loss of height will be shown. Apply full power as this stage is reached and take normal stall recovery action. If the wing drops at the point of stall and the ailerons on the type are not effective at this point, stress that the principle of using the aileron to control wing position through the rate of turn indicator must be changed. In this case the yaw towards the lowered wing should be controlled with rudder, and only when the aeroplane is unstalled can aileron again be used to control the turn needle.

UNUSUAL ATTITUDES AT HIGH AIRSPEEDS

Full Panel. From level flight dive the aeroplane steeply, both with the wings level and with bank applied. Show that all the instruments are operative and will allow the student to interpret the nose-down and banked attitude. Stress that in the case of an unusual attitude at high airspeed it is essential to level the wings before pulling out of the dive. A combination of nose-down attitude and bank results in a spiral dive and any attempt to recover without first rolling the aeroplane level will only tighten the spiral and aggravate the situation. By reference to the AI show that it is a simple matter to roll the aeroplane level and then ease out of the dive to regain level flight. Throttling back assists in keeping height loss to a minimum, and the student must have it emphasized that at any indication of a high speed diving spiral he should throttle back and level the wings simultaneously.

Limited Panel. Put the aeroplane into a straight dive with the AI and DI covered. Point out the increasing airspeed and loss of height. Throttle back and ease out of the dive, laying great emphasis on the indications of the ASI compared with the aeroplane's attitude relative to the natural horizon. **The moment the airspeed stops increasing the aeroplane is approximately in the level flight attitude.** As when leveling off from a steep climb, maintain level flight by reference to the altimeter as speed decreases, and increase power as normal cruising speed is reached.

Dive the aeroplane again, this time applying bank so that the aeroplane commences a spiral dive. Point out that the turn needle shows the direction of the spiral and that as before, it is essential to roll the aeroplane laterally level before pulling out of the dive. During the recovery the wings will be approximately level when the turn needle 'leaves the stops'.

To summarize:

- Before easing out of the dive, regain lateral level by taking off bank until the turn needle is central
- Reduce power to minimize the loss of height
- Cage and uncage the DI when the aeroplane is approximately in level flight to assist in maintaining lateral level



THROUGH INSTRUMENTS

The above exercises should be repeated under simulated instrument conditions. It is essential to once again stress that the physiological sensations that the student will experience are very disconcerting. These sensations are strongest when there is any uncertainty as to attitude and they must not be allowed to influence either the recognition of attitude or the subsequent recovery action.

LIGHT AEROPLANE – STANDARD NOSE LOW RECOVERY TECHNIQUE

SIMULTANEOUSLY

- Airspeed rapidly approaching or exceeding maximum maneuvering speed – CLOSE THROTTLE (Otherwise leave power as is.)
- ROLL WINGS LEVEL

Then

- EASE OUT OF DIVE

COMMON FAULTS

Failure to cross-refer to all instruments is a frequent weakness. Emphasize the importance of using all the instruments so as to get a comprehensive picture of the overall situation.

Note: There are divided views regarding when instrument flying should be taught. One approach is for the instructor to draw little attention to the AI until after initial circuit training. This approach is thought to enhance a student's perspective of pitch attitude as well as bank angle judgement. However, another view is to relate instrument indications during the teaching of basic sequences. However, individual school policy on this matter will depend on what is stated in the company operations manual or other appropriate document.



18 NIGHT FLYING

AIM

To teach the student how to control the aeroplane at night, on the ground and in the air.

INSTRUCTIONAL GUIDE

Night flying is a compromise between instrument and visual flight. Another explanation is that night flying in this context is instrument flying combined with visual lookout techniques. These concepts need to be emphasized from the beginning of the exercise. Before students undertake night solo circuit operations they must have received sufficient instrument flight training to enable them to carry out the following manoeuvres solely by reference to instruments:

- (a) climb and climbing turns
- (b) straight and level flight and level turns
- (c) descent and descending turns
- (d) unusual attitude recovery full panel

Prior to solo cross country flight at night a pilot must be competent at joining, departing and operating in a circuit area remote from extensive ground lighting, and unusual attitude recovery with the loss of the DG and AI.

Whenever possible, a collective briefing of all pilots engaged in a particular night flying programme should be held and the following points should be covered:

- (a) the lay out of the runway, taxiway and other airfield lights
- (b) ATC information, to include:
 - (i) taxiing procedures
 - (ii) circuit direction and height;
 - (iii) the number of aeroplanes engaged in night flying at a given time
 - (iv) radio procedures and frequencies and
 - (v) emergency procedures
- (c) meteorological information and

- (d) where night pilot navigation exercises are to be carried out, details of other airfield night flying activities, also serviceability, frequencies and call signs/designations of en route and diversion radio navigation aids.

Precautions necessary to adapt the eyes to night vision should be explained and the student warned against looking at any bright light which will lengthen the time required for night adaptation.

It is extremely important that a student be given a thorough pre-flight briefing. The type of briefing will depend on the stage reached by the student. For the purpose of this manual night flying exercises and associated briefings are considered under two headings:

- (a) Circuits and landings
- (b) Pilot navigation by night

PRE-FLIGHT BRIEFING CONSIDERATIONS

CIRCUITS AND LANDINGS

COCKPIT AND ENGINE STARTING CHECKS

A thorough knowledge of the location and method of operation of all cockpit controls and switches is essential. Ensure that the student knows how to control the brilliance of internal cockpit lighting and impress the importance of keeping this as low as possible. Mention should be made of the generator/alternator charging rate and the minimum RPM necessary for this charge rate.

Any local rules with regard to engine starting and taxiing in the tarmac area should be explained.

TAXIING

Taxiing at night requires considerable extra care compared with taxiing by day, for the following reasons:

- (a) Distance at night is deceptive when judged by stationary lights, which may be nearer than they appear.

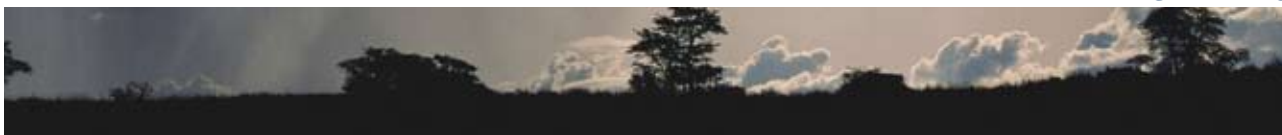

(b) Speed is deceptive, consequently there will be a tendency to taxi too fast.

(c) A careful lookout must be maintained for lights of other aeroplanes and other obstructions.

TAKE-OFF

The take-off is similar to that by day. Directional control is maintained initially by reference to the flare path. As soon as the aeroplane is airborne, transfer to instruments with particular emphasis on maintaining the attitude (especially ensuring a positive climb rate is maintained) and keeping straight. In this way the aeroplane is climbed away immediately it becomes airborne, precluding any risk of striking the ground shortly after take-off. The slight risk due to climbing at a lower airspeed than normal is accepted to gain this positive climb away from the ground. The attitude seen directly after take-off should be maintained solely by reference to instruments until the altimeter indicates a safe height and the VSI indicates a positive rate of climb. On aeroplanes equipped with retracting undercarriage and flaps, no attempt should be made to retract either until this height has been reached.

ENGINE FAILURE AFTER TAKE-OFF

In the event of engine failure at night the normal engine failure after take-off procedures should be adopted and the landing light(s) should be used as an aid to avoid obstacles.

THE CIRCUIT

The circuit pattern to be followed at night is normally the same as that flown by day and is flown mainly by reference to instruments, using the airfield lighting as a means of monitoring the aeroplane's position. Pilots should be warned of the tendency to over bank at night. The student must be briefed on radio procedures where they differ from procedures normally used by day.

APPROACH

Powered approaches should be carried out at night. The approach is judged by reference to the flare path as seen after turning on to final approach. If the approach path is correct the distance between the flare path lights will remain equidistant. If the pilot is overshooting, the distance between lights appears to increase, and if undershooting, the distance between lights appears to decrease.

An alternative method of judging the correctness of the final approach path is shown in Figure 18-1:

- If the upwind runway lights appear to significantly converge the approach is too low
- If the runway lights appear almost parallel along their entire length the approach is too high

Some airfields may have such aids as VASIS installed, but it should be emphasized that they should only be used as an aid to the pilot's judgment. On no account should an approach at night be carried out referring only to such aids. The importance of turning from the base leg on to final approach at the correct height and distance from the flare path must be emphasized. Normally the turn on to final approach should be completed by not lower than 500FT above the ground.

LANDING

The landing at night is made by reference to the flare path. Owing to the deceptive appearance of the ground, no attempt should be made to refer to it as is done by day. The effect of night conditions on inexperienced pilots frequently induces a tendency to round out and hold off too high.

The use of landing lights is normally delayed until a student has displayed the ability to consistently land safely without their use. When landing lights are used students must be warned not to look directly down the beam but slightly ahead and to one side of it.

Possible cues to a good landing at night in a light aeroplane is to consider the commencement of the flare when the flare path 'appears to be above your feet', actually commencing the flare when the flare path gives the appearance of 'passing either side of your middle'. The 'hold off' commences when the flare path appears to be at 'ear level'.



Figure 18-1: Night flying final approach in the circuit.

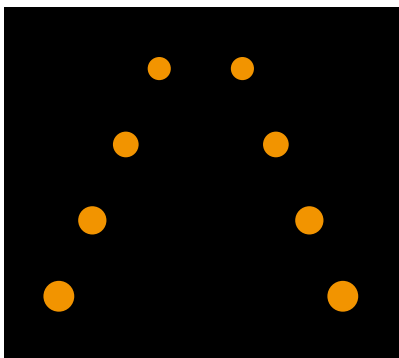

TOO LOW
Lights appear to be significantly converging

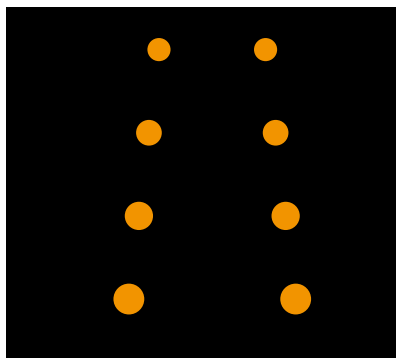

NORMAL
Lights appear to be slightly converging

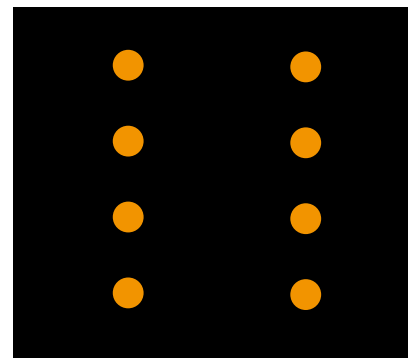

TOO HIGH
Lights appear to be almost parallel

PILOT NAVIGATION BY NIGHT

Prior to the actual briefing on this exercise, the pilot must be acquainted with the operational standards and aeroplane equipment and instrumentation requirements which must be met before night flying is permitted outside the circuit area of an airfield.

The principles of navigation at night are basically similar to those applicable by day, except that map reading at night calls for a special technique. The aeroplane is navigated according to a predetermined flight plan which is corrected from time to time by use of reliable pin points and radio navigation aids.

Some instructors advocate preparation of a sketch map of the route, which will include sufficient data to limit (or negate) the use of various pieces of in-flight documentation. This technique can be especially helpful if the aeroplane is not equipped with an auto pilot.

A comprehensive briefing is essential to the success of a night cross-country exercise. A thorough study of the meteorological forecast for the route must be made and an accurate flight plan compiled.

If forecast or reported actual meteorological conditions indicate any segment of the flight cannot be conducted within all the criteria for VFR then the flight should not commence.

The route selected should take into account the availability of features of use at night, such as lights of large towns,

aerodrome and coastal lights and rotating beacons. The lights of vehicles on a busy major road can also be of value. Lakes and other water features show up well on moonlit nights, especially when viewed against the moon.

It may be beneficial to plan a route to a destination via good night pin points even if this involves a greater mileage. The use of radio navigation must be considered and its limitations must be stressed. The planned altitudes must be either above the lowest safe altitude for particular segments or sufficient to ensure at least 1,000FT above any obstruction within ten miles either side of track.

Accurate heading and time keeping is essential and corrections should be made only when positions fixed either by pin point or radio navigation aids are positive.

EMERGENCIES LOST PROCEDURES

The procedure to be adopted when lost at night remains substantially the same as by day, although the pilot must be aware that the choice of alternate aerodromes is more limited. Brief on the importance of seeking navigational assistance from ATS immediately there are doubts as to position.

Point out there are many ways in which ATS can help in such circumstances, such as radar coverage, radio direction finding and arranging for lights to be displayed near the aeroplane's probable position. Additionally, the police radio network may be used to determine what town you are orbiting.

It must be stressed that where a flight is planned to a destination not equipped with a suitable radio navigation aid,



sufficient fuel must be carried for flight to an alternate landing ground so equipped, which must be within one hour's flight time of the destination.

ENGINE FAILURE

Should this happen away from the aerodrome the pilot should immediately endeavor to re-start the engine and send out a 'MAY DAY' call. The aeroplane should be flown at a low forward airspeed consistent with maintaining full control without an excessive rate of descent. Check that the latest value of the Area QNH is set on the altimeter and consider the altitude indicated against the known height of terrain. Consideration should be given to using only the optimum flap setting, as greater settings may lead to undesirably steep attitudes - it is obviously preferable to touch down in a flat attitude. Use of landing lights in the latter stages will be beneficial.

AIR EXERCISE

CIRCUITS AND LANDINGS

- (a) Cockpit checks and engine starting
- (b) Taxiing
- (c) Take-off, circuit, approach and landing
- (d) Overshooting at night
- (e) Pilot navigation at night

COCKPIT CHECKS AND ENGINE STARTING

Carry out the normal external and internal checks before flight but in addition, check all night flying equipment, such as navigation and landing lights and internal cockpit lights. Ensure that the navigation lights are switched on before starting the engine and after starting set the desired RPM to maintain an adequate generator/ alternator charge.

TAXIING

Emphasize the necessity for extra caution when taxiing at night owing to the deceptiveness of both speed and distance. Watch for a tendency to taxi too fast. Show the taxiway lighting and indicate the route to be followed.

If possible hold at the holding point or in the run up bay in such a position that a following aeroplane will see two navigation lights. Stress the necessity of ensuring that parking brakes are on and effective, and also that engine idling RPM is sufficient.

TAKE-OFF

Maintain directional control during the take-off run by primarily watching the flare path supplemented by reference to the instruments. When safely airborne, however, transfer attention entirely to the instruments. This will be effected more easily if some reference has been paid to them during the actual take-off run.

Once airborne, stress the necessity of maintaining the attitude by reference to the AI, keeping the wings level until the altimeter indicates the aeroplane is well clear of the ground and the VSI indicates a steady rate of climb. No attempt should be made to retract landing gear and flaps until this stage has been reached.

CIRCUIT

After take-off at night, the aeroplane should be climbed straight ahead to a minimum height of 500 feet. Stress the importance of not looking back for the flare path until the aeroplane is stabilized on the cross wind leg of the circuit. Plan the circuit so that it is not too tight and adequate time is left for engine handling procedures, checks, and actions in the unfamiliar conditions of night flying.

Point out that the circuit is flown mainly by reference to instruments and the aeroplane's position monitored by continual reference to the airfield lighting. Indicate also other aeroplane's positions in the circuit, emphasizing the importance of maintaining a good lookout and providing adequate spacing.

APPROACH

The turn on to final approach should normally be completed by no lower than 500 feet above the ground.

A flare path demonstration should be given to the student on the initial night flight. This is best achieved by turning on to final approach further back from the flare path than normal the aeroplane then being below the ideal approach path. Hold height after the turn and point out the closeness of the lights on the flare path. As the flare path is approached indicate how the distance between lights will increase. The ideal distance should be indicated and later, as height is maintained, the distance between lights will still further widen showing that the aeroplane is now too high and overshooting.

After overshooting from the above demonstration turn on to final approach at the correct height and distance out from the flare path. Point out again how the flare path is used to recognize the over or undershooting conditions. If the airfield is equipped with VASIS or approach path indicators, stress the



importance of using these only as an aid to the pilot's judgment which primarily is based on impressions gained by the look of the actual flare path. The aim of the approach should be to round out and hold off not before the 500FT markers.

The use of landing lights should only be demonstrated and practiced after a student has attained a consistently safe standard of approaches and landings without their use. When used, emphasize the importance of looking slightly ahead and to one side of the actual beam.

LANDING

Point out that landing by night involves judgment of height above the ground by reference to the flare path lights and that no attempt must be made to look for the actual ground. The most frequent fault, especially in early stages of night flying training, is for students to round out and hold off too high. After touchdown, stress that no attempt must be made to turn off the flare path until the aeroplane has been braked nearly to a standstill. When landing lights are used, emphasize that the initial round out should still be made by reference to the flare path. Students frequently show a tendency to round out late when initially using landing lights.

GOING AROUND AT NIGHT

Point out that this exercise requires no special technique other than that it is done primarily by reference to instruments. However, warn the pilot against premature retraction of landing gear and flaps during the overshoot.

COMMON FAULTS

Common faults displayed by students at night include:

- (i) Taxiing too fast. This is sometimes occasioned by the belief that high idling RPM must be maintained even whilst taxiing at night
- (ii) Failure to maintain an accurate heading after take-off, caused by over-concentration on other instruments
- (iii) Failure to track parallel to the flare path on the down wind leg due to either inability to assess any drift or to hold a constant heading
- (iv) Failure to establish a steady rate of descent on the base leg resulting in too high a turn on to the final approach
- (v) Looking for the ground during both the round out and the hold off period
- (vi) After landing trying to turn off the runway at too high a speed

PILOT NAVIGATION AT NIGHT

Choose a route bearing in mind the principles outlined in the Pre-Flight Briefing Considerations.

The feasibility of map reading will obviously depend on the state of the weather and the moon. Individual lights such as aerodrome beacons and coastal lights are most useful but watch for errors arising from the student's estimation of distance from them. As the usual tendency is to underestimate distance, make the utmost use of a combination of map ground features and lights to demonstrate the extent of this error until the student is capable of readjusting his perception to give more accurate estimates.

Avoid the use of small lights on the ground (except navigation aids), as particularly in the early stages the scattered lights around small communities may give the impression of quite large towns.

Demonstrate the use of all available radio aids, using the same procedure as by day. Point out any limitations of these navigation aids under night operating conditions.

At all times ensure that the student is aware of the approximate bearing and distance of a prominent, unmistakable feature which can be reached reasonably easily should there be a breakdown in navigation.

COMMON FAULTS

Students frequently experience difficulty in reading their map and navigation log in the comparatively dim cockpit lighting, this difficulty leading to large errors in heading, altitude and airspeed. This problem is overcome with experience and also clearly underlines the necessity for thorough and methodical flight planning and the use of a sketch map.

A common fault, as previously mentioned, is for students to considerably underestimate their distance from known lights. Only experience and guidance from the instructor will eradicate this fault.