



TP 2076E
November 1997

In strument procedures manual



Transport Canada
Safety and Security
Civil Aviation

Transports Canada
Sécurité et sûreté
Aviation civile

T P 2 0 7 6 E

FOURTH EDITION 1997

Revised: November 1997



Copyright © Minister of Supply and Services Canada, 1995

Issued under the authority of the Minister of Transport

First edition - 1984

Second edition - 1987

Third edition - 1995

Fourth edition - 1997

Available in English or French in Canada through many aviation book stores and other booksellers or by mail from

AERONAUTICAL PUBLICATION SERVICES (AARNG)

TRANSPORT CANADA

Place de Ville

Ottawa, Ontario

K1A 0N8

Tel: 1-800-305-2059

613-993-7284

Fax: 613-998-7416

Internet: <http://www.tc.gc.ca/aviation>

Also available in English and French combined on CD-ROM.

Catalogue No. T52-54/1997E

ISBN 0-660-17258-5

Copyright

All rights reserved by Transport Canada. No part of this publication may be reproduced or transmitted in any form or by means now known or to be invented, electronic or mechanical, including photocopying, recording, or by any information storage or retrieval system without written permission from Transport Canada, except for the brief inclusion of quotations in a review.

The information in this publication is to be considered solely as a guide and should not be quoted as or considered to be a legal authority. It may become obsolete in whole or in part at any time without notice.

Printed and bound in Canada

Published and distributed by Transport Canada

WARNING:

The information in this publication is current only to date of submission for printing. *CANADA AIR PILOT (CAP)*, *CANADA FLIGHT SUPPLEMENT (CFS)*, *AERONAUTICAL INFORMATION PUBLICATION (AIP Canada)*, *NOTAMs*, *Information Circulars* and amendments to *Air Regulations* that affect any information in this publication, which are issued subsequently, may amend or supplement the information in this manual. They must *therefore* be consulted to *ensure* that information being used is current.

FOREWORD

Welcome to the challenging world of instrument flying! Instrument Flight Rules (IFR) operation has become the most common mode for cross-country travel for both general aviation and the airlines. Therefore, it is necessary for IFR pilots to understand thoroughly the functions and limitations of the system, and the procedures which must be followed.

This manual provides students and experienced pilots with information on today's aircraft, satellite and ground-based instrument systems, departure, en route and approach procedures, and air traffic control regulations. The emphasis is on approaches, because any malfunction or misinterpretation is most critical in this segment of flight.

The *first part* of the manual, which deals with the physiological effects and human factors encountered in instrument flying, applies to both pilots in training and seasoned IFR pilots. The *second part* reviews the nature and use of principal cockpit instruments, the major instrument systems on board, radio navigation systems and an introduction to basic instrument flying. It should be read by pilots in training.

Both experienced and student pilots should peruse *Part 3*, which outlines specific air traffic control procedures for IFR operation, from airspace through to radio procedures.

Part 4 deals with IFR flight procedures from flight planning to the termination of the flight. It should be read by all instrument pilots. *Part 5* outlines the theory and application of helicopter attitude instrument flying. *Part 6* gives a brief outline of suggested IFR training programs including lesson plan titles and length.

Much of the information in this manual is drawn from the *Air Regulations*, The *Canada Air Pilot*, the *Air Traffic Control Manual of Operations* (MANOPS) and the *A.I.P. Canada*. The reader should have access to the *Canada Air Pilot*, the *Canada Flight Supplement* and *En route and Terminal Area Charts* as he or she reads Part 4 - IFR Flight Procedures.

Pilots are cautioned that although this manual was current at the time of going to print, certain information may change from time to time. Therefore, it is imperative that the latest information provided in *AIP Canada*, *CAP* and *CFS* be used while flying at all times.

Please address corrections
additions
suggestions to:

Transport Canada
AARRE
Ottawa, Ontario
K1A 0N8

Fax: 613-990-6215



EDITORS

FLIGHT TRAINING (AARRE)

Ross Beck

Guy Labrie

The editors wish to thank the following individuals and their respective organizations within Transport Canada for their valuable contributions to this manual:

DIAGRAMS, MAPS

AERONAUTICAL INFORMATION SERVICES (AARN)

GRAPHIC DESIGN, LAYOUT,
PHOTOGRAPHY, COVER

TRAINING TECHNOLOGY SECTION (AARE - TTS)

AEROMEDICAL SECTION

CIVIL AVIATION MEDICINE (AARG)

HELICOPTER SECTION

FLIGHT TRAINING AND AIR CARRIER STANDARDS

Bill Ostrander

Rob Freeman

FRENCH VERIFICATION

FLIGHT TRAINING (AARRE)

Guy Labrie

PART 1 :
PHYSIOLOGICAL FACTORS RELATED TO INSTRUMENT FLIGHT

1.1 INTRODUCTION 1-2
1.2 OXYGEN AND ALTITUDE 1-2
1.3 OTHER EFFECTS 1-4
1.4 ORIENTATION AND DISORIENTATION 1-5

PART 2 :
INSTRUMENTATION, NAVIGATION SYSTEMS AND BASIC INSTRUMENT FLYING

2.1 INSTRUMENTS 2-2
2.2 NAVIGATION SYSTEMS 2-33
2.3 BASIC INSTRUMENT FLYING 2-63

PART 3 :
AIR TRAFFIC SERVICES

3.1 INTRODUCTION TO AIR TRAFFIC SERVICES 3-2
3.2 CANADIAN AIRSPACE 3-13
3.3 IFR SEPARATION 3-21
3.4 RADIO PROCEDURES 3-24

PART 4 :
IFR FLIGHT PROCEDURES

4.1 FLIGHT PLANNING 4-2
4.2 DEPARTURE PROCEDURES 4-7
4.3 EN ROUTE PROCEDURES 4-15
4.4 HOLDING PROCEDURES 4-19
4.5 ARRIVAL PROCEDURES 4-23
4.6 INSTRUMENT APPROACH PROCEDURES 4-36
4.7 EMERGENCIES 4-60
4.8 TRANSPONDER OPERATION 4-63

PART 5 :
HELICOPTER ATTITUDE INSTRUMENT FLYING

5.0 DEFINITIONS 5-2
5.1 THEORY 5-4
5.2 ATTITUDE AND POWER CONTROL 5-4
5.3 STABILIZATION SYSTEMS 5-9
5.4 INSTRUMENT FLIGHT 5-9
5.5 HELICOPTER APPROACHES 5-12
5.6 EMERGENCIES 5-13

PART 6 :
IFR TRAINING PROGRAMME

6.1 INTRODUCTION 6-2
6.2 GROUND TRAINING 6-3
6.3 SYNTHETIC FLIGHT TRAINING 6-8
6.4 FLIGHT TRAINING 6-10

APPENDICES:

APPENDIX 1: DEFINITIONS APP-2
APPENDIX 2: ABBREVIATIONS APP-10
APPENDIX 3: RULES OF THUMB APP 15
APPENDIX 4: REFERENCES FOR INSTRUMENT FLYINGAPP-18



T A B L E
 OF
 CONTENTS

P A R T 1 :
 PHYSIOLOGICAL FACTORS RELATED TO INSTRUMENT FLIGHT

1.1 INTRODUCTION

1.2 OXYGEN AND ALTITUDE

1.2.1 The Atmosphere 1-2

1.2.2 From the Air to the Tissues 1-2

1.2.3 Altitude Effects 1-3

1.2.4 Hypoxia 1-3

1.2.5 Prevention of Hypoxia 1-3

1.2.6 Hyperventilation 1-3

1.2.7 Treatment of Hypoxia and Hyperventilation 1-4

1.3 OTHER EFFECTS

1.3.1 The Effects of Alcohol 1-4

1.3.2 Drugs 1-4

1.3.3 Fatigue 1-4

1.4 ORIENTATION AND DISORIENTATION

1.4.1 Introduction 1-5

1.4.2 Sensory Illusions 1-5

a. *Kinesthetic Illusions* 1-5

b. *Visual Illusions* 1-5

1. White-Out and Black Holes 1-6

2. False Horizons 1-6

c. *Vectional Illusions* 1-6

d. *Vestibular illusions* 1-7

1. Linear Accelerations 1-7

2. Angular Accelerations 1-7

3. Graveyard Spin 1-8

4. Coreolis Effects 1-8

5. The Leans 1-8

1.4.3 General Factors 1-8

1.4.4 Preventing Disorientation 1-9

1.4.5 Overcoming Disorientation 1-9

P A R T 2 :
 INSTRUMENTATION, NAVIGATION SYSTEMS AND BASIC INSTRUMENT FLYING

2.1 INSTRUMENTS

2.1.1 INTRODUCTION

- a. Aircraft Instrumentation 2-2
- b. Instrument Range Markings 2-3
- c. Lighting 2-4
- d. Instrument Malfunctions 2-4
- e. Basic “T” Instrument Panel 2-4

2.1.2 PILOT-STATIC SYSTEM AND INSTRUMENTS 2-5

- a. General 2-5
- b. Principles 2-6
- c. Inherent Errors 2-6
- d. System Malfunctions 2-7
- e. Pilot Checks 2-7
- f. Pitot-static Instruments 2-8
 - 1. *Airspeed Indicator and V Speeds* 2-8
 - 2. *Altimeter* 2-9
 - 3. *Radar Altimeter* 2-11
 - 4. *Altitude Alerting Systems* 2-11
 - 5. *Vertical Speed Indicator* 2-12
 - 6. *Instantaneous Vertical Speed Indicator* 2-12
- g. Air Data Systems 2-12
 - 1. *General* 2-12
 - 2. *Components* 2-13
 - 3. *Air Data Outputs* 2-13
 - 4. *Inherent System Errors* 2-13
- h. Angle-of-Attack System 2-14
 - 1. *General* 2-14
 - 2. *System Components* 2-14

2.1.3 GYROSCOPIC SYSTEMS AND INSTRUMENTS 2-14

- a. General 2-14
- b. Principles 2-15
 - 1. *Rigidity in Space* 2-15
 - 2. *Precession* 2-15
- c. Gyro Power Sources 2-16
 - 1. *Vacuum Power System* 2-16
 - 2. *Electrical Power System* 2-16
- d. Gyroscopic Instruments 2-16
 - 1. *Attitude Indicator* 2-16
 - 2. *Heading Indicator* 2-17
 - 3. *Rate and Quality of Turn Indicators* 2-18
 - 4. *The Gyrosyn Compass System* 2-20



2.1.4	MAGNETIC COMPASS	2-21
a.	General	2-21
b.	Principles	2-21
c.	Magnetic Dip	2-21
d.	Compass Construction	2-22
e.	Compass Errors	2-22
1.	<i>Deviation</i>	2-22
2.	<i>Dip Error</i>	2-23
f.	Use of the Magnetic Compass	2-24
2.1.5	FLIGHT DIRECTOR SYSTEMS	2-24
a.	General	2-24
b.	Flight Director Indicator	2-24
1.	<i>Fixed Aircraft Symbol</i>	2-24
2.	<i>Command Bars</i>	2-24
3.	<i>Glide Slope Indicator</i>	2-24
4.	<i>Localizer Deviation Pointer</i>	2-24
5.	<i>Slip Indicator</i>	2-25
6.	<i>Flight Director Control Panel</i>	2-25
c.	Horizontal Situation Indicator	2-25
d.	Flight Director Computer	2-26
e.	Other Types of Flight Director Systems	2-26
f.	Electronic Flight Instrument System	2-26
1.	<i>Primary Flight Display (PFD)</i>	2-27
2.	<i>Navigation Display (ND)</i>	2-27
3.	<i>Display Select Panel (DSP)</i>	2-27
4.	<i>Display Processor Unit</i>	2-27
5.	<i>Weather Radar Panel</i>	2-27
6.	<i>Multifunction Display</i>	2-28
7.	<i>Multifunction Processor Unit</i>	2-28
2.1.6	MISCELLANEOUS INSTRUMENTS.....	2-28
a.	TCAS.....	2-28
b.	HUD	2-30
c.	Weather Radar	2-31
d.	Mode S Transponder	2-32
e.	GPWS.....	2-33
f.	Instrument Comparator	2-33

2.2 NAVIGATION SYSTEMS

2.2.1	INTRODUCTION	2-33
2.2.2	NAVIGATION AIDS (NAVAIDS)	2-33
a.	Radio Theory	2-33
1.	<i>Wave Characteristics</i>	2-33
2.	<i>Radio Frequency Categories</i>	2-34
3.	<i>Radio Waves</i>	2-34
4.	<i>Radio Propagation</i>	2-35
5.	<i>Interference to Aircraft Navigation Equipment</i>	2-35
b.	Very-high and Ultra-high-frequency Radio Aids	2-35
1.	<i>VOR</i>	2-35

2.	<i>TACAN</i>	2-36
3.	<i>VORTAC</i>	2-36
4.	<i>VHF Direction Finding</i>	2-36
5.	<i>Omnitest or VOR Equipment Test</i>	2-36
c.	Radar Systems	2-36
d.	Precautionary Use of Navigation Aids	2-37
2.2.3	VOR NAVIGATION	2-37
a.	General	2-37
b.	VOR Accuracy	2-38
1.	<i>Requirement for Checks</i>	2-38
2.	<i>VOR Test Facility</i>	2-38
3.	<i>VOR Check Point Signs</i>	2-38
4.	<i>Dual VOR Check</i>	2-38
5.	<i>Airborne VOR Check</i>	2-38
c.	Aircraft VOR Components	2-38
1.	<i>VOR Receiver</i>	2-38
2.	<i>Navigation Indicator</i>	2-39
3.	<i>Track Arrow</i>	2-39
4.	<i>Reference Line</i>	2-39
d.	Determination of Position	2-40
1.	<i>Heading</i>	2-40
2.	<i>Position Fix</i>	2-40
e.	Flight to a VOR Station	2-40
1.	<i>Bracketing</i>	2-40
2.	<i>Track to the Station</i>	2-41
3.	<i>Time Check</i>	2-41
2.2.4	DISTANCE MEASURING EQUIPMENT.....	2-42
a.	General	2-42
b.	Basic Principles	2-42
c.	DME Components and Operations	2-42
d.	Flying a DME Arc	2-43
1.	<i>Calm Conditions</i>	2-43
2.	<i>Wind Drift</i>	2-44
3.	<i>Arcing to a Final Approach</i>	2-44
2.2.5	AUTOMATIC DIRECTION FINDER SYSTEM	2-44
a.	Description	2-44
b.	Limitations and Benefits	2-44
c.	ADF Components	2-45
1.	<i>Receiver</i>	2-45
2.	<i>Control Box-Digital Readout Type</i>	2-46
3.	<i>Antennae</i>	2-46
4.	<i>Bearing Indicator</i>	2-46
d.	ADF Operations	2-47
1.	<i>Monitoring</i>	2-47
2.	<i>Homing</i>	2-47
3.	<i>Tracking from a Station</i>	2-48
4.	<i>Position Fix by ADF</i>	2-48
5.	<i>Time Computation</i>	2-48



2.2.6	RADIO MAGNETIC INDICATOR	2-48
2.2.7	THE INSTRUMENT LANDING SYSTEM (ILS)	2-49
	a. General Description	2-49
	b. Localizer	2-49
	1. <i>Ground Equipment</i>	2-49
	2. <i>Signal Transmission</i>	2-50
	3. <i>Localizer Receiver</i>	2-50
	c. Glide Slope Equipment	2-51
	1. <i>Transmitter</i>	2-51
	2. <i>Signal Receiver</i>	2-51
	d. ILS Marker Beacons	2-52
	1. <i>General</i>	2-52
	2. <i>Outer Marker (OM)</i>	2-52
	3. <i>Middle Marker (MM)</i>	2-52
	4. <i>Back Marker (BM)</i>	2-53
	e. Lighting Systems	2-53
	1. <i>General</i>	2-53
	2. <i>Runway Visibility Measurement</i>	2-53
	3. <i>Runway Visual Range (RVR)</i>	2-53
	f. NDBs at Marker Beacon Sites	2-54
2.2.8	MICROWAVE LANDING SYSTEM	2-54
	a. System Description	2-54
	b. ILS Limitations	2-55
	c. MLS Advantages	2-55
	d. Approach Azimuth Guidance	2-55
	e. Back Azimuth Guidance	2-55
	f. Elevation Guidance	2-56
	g. Range Guidance	2-56
	h. Data Communications	2-56
2.2.9	AREA NAVIGATION	2-56
	a. General	2-56
	b. VOR/DME	2-56
	c. Loran C	2-57
	d. GPS	2-58
	1. <i>How does GPS work?</i>	2-58
	2. <i>Differential GPS</i>	2-58
	3. <i>Accuracy, Availability and Integrity</i>	2-58
	4. <i>GPS Approaches</i>	2-59
	5. <i>En route and Terminal Operations</i>	2-59
	e. OMEGA	2-59

f. INS - Inertial Navigation	2-59
1. <i>The System</i>	2-59
2. <i>Operation</i>	2-60
3. <i>Errors</i>	2-60
4. <i>Ring Laser Gyro</i>	2-61
5. <i>RLG in an INS</i>	2-61
6. <i>The Strapdown INS</i>	2-61
7. <i>Advantages of a RLG</i>	2-61
8. <i>Pilot Procedures</i>	2-61
g. FMS - Flight Management System	2-62
h. <i>Airspace</i>	2-62

2.3 BASIC INSTRUMENT FLYING

2.3.1 ATTITUDE INSTRUMENT FLYING.....	2-63
a. <i>Introduction</i>	2-63
b. <i>Concept</i>	2-63
c. <i>Attitude and Power Control</i>	2-64
d. <i>Trim Technique</i>	2-64
e. <i>Scan Technique</i>	2-64
f. <i>Adjusting Attitude and Power</i>	2-65
2.3.2 ATTITUDE INSTRUMENT FLYING MANOEUVRES	2-66
a. <i>Stalls and Stall Recovery</i>	2-66
1. <i>Approach Stalls</i>	2-66
2. <i>Take-off and Departure Stalls</i>	2-67

PART 3 :
AIR TRAFFIC SERVICES

3.1 INTRODUCTION TO AIR TRAFFIC SERVICES

3.1.1	AIR TRAFFIC SERVICES	3-2
	a. Air Traffic Control.....	3-2
	b. Flight Service Stations	3-2
	1. <i>Pre-Flight Planning Service</i>	3-3
	2. <i>Airport Advisory Service</i>	3-3
	3. <i>Vehicle Control Service</i>	3-3
	4. <i>Remote Airport Advisory and Remote Vehicle Control Service</i>	3-3
	5. <i>En route Flight Information Service</i>	3-4
	6. <i>Emergency Service</i>	3-4
	7. <i>VFR Flight Plan Processing and Alerting Service</i>	3-4
	8. <i>Weather Observing Service</i>	3-4
	9. <i>NAVAIDS Monitoring Service</i>	3-4
	10. <i>Broadcast Service</i>	3-4
3.1.2	FLIGHT INFORMATION SERVICE	3-4
	a. General	3-4
	b. Bird Activity Information	3-5
	c. Chaff Information	3-5
	d. Severe Weather Information	3-5
	e. Automatic Terminal Information Service (ATIS)	3-5
3.1.3	IDENTIFICATION OF AIR TRAFFIC SERVICES UNITS	3-6
3.1.4	UNITS OF MEASUREMENT	3-6
3.1.5	FLIGHT PRIORITY	3-7
3.1.6	CLEARANCES AND INSTRUCTIONS	3-7
3.1.7	NOISE ABATEMENT RUNWAY ASSIGNMENT	3-8
3.1.8	RADAR	3-8
	a. General	3-8
	b. Systems	3-8
	c. Procedures	3-9
	d. Obstacle Clearance during Radar Vectors	3-9
	e. Radar Traffic Information	3-10
	f. Severe Weather Information	3-10
3.1.9	VISUAL GROUND AIDS.....	3-10
	a. Approach Lighting Systems	3-11
	1. <i>Category I and II</i>	3-11
	2. <i>Other Types of Lighting</i>	3-11
	3. <i>Strobes</i>	3-11
	4. <i>ARCAL</i>	3-11
	b. VASIS - Visual Approach Slope Indicator System.....	3-12
	c. Aerodrome Markings.....	3-12
	1. <i>Runway Markings</i>	3-12
	2. <i>Taxiway Markings</i>	3-12
	3. <i>Ramp Markings</i>	3-12

3.2 CANADIAN AIRSPACE

3.2.1 GENERAL 3-13

3.2.2 CANADIAN DOMESTIC AIRSPACE 3-13

 a. Northern Domestic Airspace 3-13

 b. Southern Domestic Airspace 3-13

3.2.3 CONTROLLED AIRSPACE 3-13

 a. High Level Controlled Airspace 3-14

 b. Low Level Controlled Airspace 3-14

 1. *Low Level Airways* 3-14

 2. *Control Area Extensions* 3-14

 3. *Terminal Control Areas* 3-15

 4. *Control Zones* 3-15

 5. *Transition Areas* 3-15

3.2.4 ALTIMETER SETTING REGION 3-15

3.2.5 STANDARD PRESSURE REGION 3-15

3.2.6 CLASSIFICATION OF AIRSPACE 3-17

3.2.7 SPECIAL USE AIRSPACE 3-18

 a. General 3-18

 b. Military Operations Areas (MOA) 3-18

 c. Military Activity Areas (MAA) 3-18

 d. Danger Areas 3-18

 e. Restricted Areas 3-18

 f. Advisory Airspace 3-18

 g. Altitude Reservations 3-19

 h. Rocket Ranges 3-19

3.2.8 CANADIAN MINIMUM NAVIGATION PERFORMANCE SPECIFICATIONS AIRSPACE 3-19

3.2.9 NORTH ATLANTIC MNPS AIRSPACE 3-20

3.3 IFR SEPARATION

3.3.1 GENERAL 3-21

3.3.2 VERTICAL SEPARATION 3-21

 A. Minima and Procedures 3-21

 B. Separation between Flight Levels and Altitudes 3-21

3.3.3 LONGITUDINAL SEPARATION 3-21

 A. Minima and Procedures 3-21

 B. Phraseology 3-21

3.3.4 LATERAL SEPARATION 3-21

 a. General 3-21

 b. Controlled Low Level Airspace 3-22

 c. Change of Direction at and above FL 180 3-22

 d. Lateral Protected Airspace and IFR Instrument Approach Procedures (Low Altitude) 3-22

3.3.5 WAKE TURBULENCE SEPARATION 3-23



3.4 RADIO PROCEDURES

3.4.1	BASIC RADIO PROCEDURES	3-24
a.	General	3-24
b.	Radiotelephony Contact	3-24
c.	Message Acknowledgement	3-24
d.	Readability Scale and Communication Checks	3-24
3.4.2	RADIO TELEPHONE COMMUNICATIONS.....	3-25
a.	ICAO International Phonetic Alphabet/Morse Code	3-25
b.	Aircraft Call Signs	3-25
c.	Ground Station Call Signs	3-26
d.	Numbers	3-26
e.	Decimal Points	3-26
3.4.3	COMMUNICATIONS PROCEDURES AT UNCONTROLLED AERODROMES	3-26
a.	General Considerations	3-26
b.	Establishment of Mandatory Frequencies	3-27
c.	Aerodrome Traffic Frequency (ATF)	3-27
d.	Use of MF and ATF	3-27
e.	IFR Arrival Procedures at Uncontrolled Airports	3-28
f.	IFR Departure Procedures at Uncontrolled Aerodromes	3-28
g.	IFR Procedures at Uncontrolled Aerodromes in Uncontrolled Airspace	3-29
3.4.4	INTERNATIONAL AIR-GROUND COMMUNICATIONS	3-29
a.	Types of Emission	3-29
b.	Selective Call System (SELCAL)	3-29

P A R T 4 :
IFR FLIGHT PROCEDURES

4.1 FLIGHT PLANNING

4.1.1	REQUIREMENT TO FILE A FLIGHT PLAN	4-2
4.1.2	PURPOSES OF FLIGHT PLANNING	4-2
4.1.3	GENERAL CONSIDERATIONS IN FLIGHT PLANNING	4-2
4.1.4	IFR FLIGHT PLAN FORM	4-3
4.1.5	ICAO FLIGHT PLAN FORM	4-4
4.1.6	IFR FUEL REQUIREMENTS	4-4
4.1.7	CHANGES TO THE FLIGHT PLAN	4-5
4.1.8	EQUIPMENT FAILURES	4-6
4.1.9	ATC CLEARANCE	4-6

4.2 DEPARTURE PROCEDURES

4.2.1	GENERAL	4-7
4.2.2	REQUEST FOR PUSH-BACK	4-7
4.2.3	PRE-TAXI CLEARANCE PROCEDURES	4-7
4.2.4	TAXI CLEARANCE	4-8
	a. General	4-8
	b. Instrument Check	4-8
	c. Taxi Holding Position	4-9
	d. Common ATC Phraseologies	4-9
	e. Transponder	4-9
	f. Runway Selection	4-9
4.2.5	IFR CLEARANCE	4-9
	a. Basic Procedures	4-9
	b. Mach Number - Clearances	4-11
	c. Standard Instrument Departures (SID)	4-11
	d. Noise Abatement Procedures	4-12
	e. Clearance Read-back	4-12
	f. VFR Release of an IFR Aircraft	4-13
	g. Take-off Clearance	4-13
4.2.6	TAKE-OFF CRITERIA AND MINIMA.....	4-13
	a. Take-off Minima	4-13
	b. Take-off Criteria.....	4-14
	c. Obstacle and Terrain Clearance	4-14

4.3 EN ROUTE PROCEDURES

4.3.1	POSITION REPORTS	4-15
4.3.2	ALTITUDE	4-15
	a. General	4-15
	b. Minimum IFR Altitudes	4-16
	c. Altitudes in Designated Mountainous Regions	4-16
	d. Altitude Reports	4-17



4.3.3	CLIMB OR DESCENT	4-17
	a. General	4-17
	b. VFR Climb and Descent	4-17
4.3.4	IFR FORMATION FLIGHTS	4-18
4.3.5	ONE-THOUSAND-ON-TOP	4-18
4.3.6	CLEARANCE LIMIT	4-18
4.4	HOLDING PROCEDURES	
4.4.1	GENERAL	4-19
4.4.2	HOLDING CLEARANCE	4-19
4.4.3	STANDARD HOLDING PATTERN	4-20
4.4.4	ENTRY PROCEDURES	4-20
4.4.5	NON-STANDARD HOLDING PATTERN	4-20
4.4.6	TIMING	4-21
4.4.7	SPEED LIMITATIONS	4-21
4.4.8	DME HOLDING PROCEDURES	4-22
4.4.9	SHUTTLE PROCEDURE	4-22
4.4.10	HOLDING PATTERNS DEPICTED ON EN ROUTE AND TERMINAL CHARTS	4-22
4.5	ARRIVAL PROCEDURES	
4.5.1	DESCENT PLANNING.....	4-23
	a. Introduction.....	4-23
	b. Arrival Fixes	4-23
	1. <i>Terminal Area Fixes - General</i>	4-23
	2. <i>Fixes Formed by Intersections</i>	4-23
	3. <i>Fix Tolerance Factors</i>	4-23
4.5.2	STAR.....	4-24
4.5.3	PROFILE DESCENTS.....	4-24
	a. General	4-24
	b. ATC Revisions	4-24
4.5.4	ADVANCE NOTICE OF INTENT IN MINIMUM WEATHER CONDITIONS.....	4-25
4.5.5	CONTROL TRANSFER	4-25
	a. IFR Units - Towers.....	4-25
	b. Initial Contact with Towers.....	4-25
4.5.6	APPROACH CLEARANCE	
	a. General	4-26
	b. Straight-in Approaches.....	4-27
	c. Visual - Contact Approaches	4-28
	1. <i>Visual Approach</i>	4-28
	2. <i>Contact Approach</i>	4-28
	d. Position Reports.....	4-28
	e. Missed Approach Instructions.....	4-29
	f. Speed Adjustments - Radar Controlled Aircraft.....	4-29
	g. Taxiing.....	4-30

4.5.7	APPROACH AND ALTERNATE MINIMA	4-30
	a. Approach Ban	4-30
	b. Landing Minima	4-31
	1. <i>Visual References</i>	4-31
	2. <i>Altimeter Setting Requirements</i>	4-31
	3. <i>Use of Straight-in Minima</i>	4-31
	c. Alternate Minima.....	4-32
4.5.8	AIRCRAFT CATEGORIES	4-33
4.5.9	CORRECTIONS FOR TEMPERATURE	4-33
4.5.10	REMOTE ALTIMETER SETTING.....	4-33
4.5.11	TRANSITIONS TO THE APPROACH	4-34
	a. Radar Vectors	4-34
	b. On Airways	4-34
	c. Off Airways.....	4-35
	d. Arc Transitions	4-35
4.5.12	APPROACH PLANNING.....	4-35
4.6	INSTRUMENT APPROACH PROCEDURES	
4.6.1	INTRODUCTION	4-36
	a. Non-Precision Approaches (NPA)	4-37
	b. Precision Approaches.....	4-37
4.6.2	THE INSTRUMENT APPROACH PROCEDURE	4-37
	a. Procedure Construction	4-37
	b. Initial Segment	4-38
	c. Intermediate Segment	4-38
	1. <i>Straight-in Approaches</i>	4-39
	2. <i>Procedure Turns</i>	4-40
	d. Final Segment	4-42
	1. <i>Non-Precision Approaches</i>	4-43
	2. <i>Turns over the FAF</i>	4-44
	3. <i>Precision Approaches</i>	4-44
	e. Missed Approach Segment	4-44
4.6.3	VISUAL MANOEUVRING DURING APPROACHES	4-45
	a. General	4-45
	b. Transition to Visual Flight.....	4-45
	1. <i>General</i>	4-45
	2. <i>Restrictions to Visibility</i>	4-46
	3. <i>Visual Cues</i>	4-47
	4. <i>Pilot Reaction Time</i>	4-47
	c. Circling.....	4-48
	d. Missed Approach Procedure	4-49



4.6.4	NDB APPROACHES	4-49
	a. Station Passage	4-49
	b. 5-T Check.....	4-50
	c. NDB Approach - Beacon-Off-The-Field	4-50
	d. Beacon-On-The-Field Approach	4-51
4.6.5	VOR APPROACHES	4-52
4.6.6	LOC AND LOC (BC) APPROACHES	4-52
	a. LOC Approaches	4-52
	b. LOC (BC) Approaches	4-52
4.6.7	ILS APPROACHES	4-54
	a. Cat I.....	4-54
	b. Cat II.....	4-54
	c. Flying the ILS	4-54
4.6.8	RADAR APPROACHES	4-57
	a. General	4-57
	b. Precision Approach Radar (PAR)	4-57
	c. Aerodrome Surveillance Radar (ASR)	4-58
4.6.9	RNAV APPROACHES	4-58
	a. GPS Approaches	4-58
	1. <i>General Provisions</i>	4-58
	2. <i>GPS Overlay Approaches</i>	4-59
	3. <i>GPS Stand-Alone Approaches</i>	4-59
	b. Multi-Sensor Approaches	4-60
4.7	EMERGENCIES	
4.7.1	DECLARATION OF EMERGENCY	4-60
4.7.2	COMMUNICATION FAILURE IN IFR FLIGHT	4-61
4.7.3	REPORTING MALFUNCTIONS OF NAVIGATION AND COMMUNICATIONS EQUIPMENT	4-63
4.7.4	FUEL DUMPING	4-63
4.8	TRANSponder OPERATION	
4.8.1	GENERAL	4-63
4.8.2	HIGH-LEVEL AIRSPACE - IFR FLIGHT	4-64
4.8.3	LOW-LEVEL AIRSPACE - IFR FLIGHT	4-64
4.8.4	PHRASEOLOGY	4-64
4.8.5	MODE C	4-64
4.8.6	VFR FLIGHT	4-64
4.8.7	EMERGENCIES	4-65
4.8.8	COMMUNICATION FAILURE	4-65
4.8.9	UNLAWFUL INTERFERENCE (HIJACK)	4-65

P A R T 5 :
HELICOPTER ATTITUDE INSTRUMENT FLYING

5.1	DEFINITIONS	5-2
5.2	THEORY	5-4
5.3	ATTITUDE AND POWER CONTROL.....	5-4
	a. Control and Performance Instruments	5-5
	b. Pitch Attitude Control	5-6
	c. Bank Attitude Control	5-7
	d. Trim Techniques.....	5-8
	e. Instrument Cross-Check	5-8
5.4	STABILIZATION SYSTEMS.....	5-9
5.5	INSTRUMENT FLIGHT.....	5-9
5.6	HELICOPTER APPROACHES	5-12
5.7	EMERGENCIES.....	5-13
	a. Partial Panel	5-13
	b. Autorotation	5-14
	c. Unusual Attitudes	5-14
	d. Inadvertent IMC.....	5-15

PART 6 :
IFR TRAINING PROGRAMME

6.1 INTRODUCTION

6.1.1	GENERAL	6-2
6.1.2	ADVICE TO PERSONS CONDUCTING TRAINING	6-2
6.1.3	COMPLETION OF TRAINING	6-3

6.2 GROUND TRAINING

6.2.1	COURSE OUTLINE	6-3
6.2.2	INTRODUCTION	6-3
6.2.3	VFR REVIEW	6-4
6.2.4	FLIGHT PLANNING GENERAL	6-4
6.2.5	DEPARTURES	6-4
6.2.6	EN ROUTE	6-4
6.2.7	ARRIVAL	6-4
6.2.8	APPROACHES	6-4
6.2.9	EMERGENCIES	6-4
6.2.10	FLIGHT INSTRUMENTS	6-5
6.2.11	NAVIGATION INSTRUMENTS AND EQUIPMENT	6-5
6.2.12	COMPASSES	6-5
6.2.13	OTHER NAVIGATION EQUIPMENT IN USE	6-5
6.2.14	METEOROLOGY - INTRODUCTION	6-5
6.2.15	AIR MASSES	6-5
6.2.16	COLD FRONTS	6-6
6.2.17	WARM FRONTS	6-6
6.2.18	THUNDERSTORMS	6-6
6.2.19	ICING, TURBULENCE, FOG	6-6
6.2.20	CHARTS	6-6
6.2.21	WEATHER REPORTS	6-6
6.2.22	WEATHER PLANNING	6-6
6.2.23	REVIEW AND DISCUSSIONS	6-7
6.2.24	FLIGHT PLANNING IFR	6-7
6.2.25	FLIGHT PLANNING COMPUTER PROBLEMS	6-7
6.2.26	GENERAL NAVIGATION PROBLEMS	6-7
6.2.27	FLIGHT PLANNING EXERCISE	6-7
6.2.28	PRACTICE EXAM	6-7

6.3 SYNTHETIC FLIGHT TRAINING

6.3.1	Basic Instrument Review	6-8
6.3.2	Automatic Direction Finder (ADF)	6-8
6.3.3	Very High Frequency Omnidirectional Range (VOR)	6-9
6.3.4	Distance Measuring Equipment (DME)	6-9
6.3.5	Holding	6-9
6.3.6	Approaches and Missed Approaches	6-9
6.3.7	Air Traffic Services (ATS) Clearances/Procedures	6-10
6.3.8	IFR Cross Country	6-10

6.4 FLIGHT TRAINING

6.4.1	INSTRUMENT FLYING	6-11
6.4.2	AUTOMATIC DIRECTION FINDER (ADF)	6-11
6.4.3	VERY HIGH FREQUENCY OMNIDIRECTIONAL RANGE (VOR)	6-11
6.4.4	DISTANCE MEASURING EQUIPMENT (DME)	6-11
6.4.5	HOLDING	6-11
6.4.6	APPROACHES AND MISSED APPROACHES	6-12
6.4.7	AIR TRAFFIC SERVICES (ATS) CLEARANCES/PROCEDURES	6-12
6.4.8	IFR CROSS COUNTRY	6-12

APPENDIX 1:

Definitions	APP-2
-------------------	-------

APPENDIX 2:

Abbreviations	APP-10
---------------------	--------

APPENDIX 3:

Rules of Thumb	APP-15	
3.1	GROUNDSPEED CHECK	APP-15
3.2	APPROXIMATE BANK ANGLE FOR RATED TURNS	APP-15
3.3	RATE OF DESCENT TO FLY A GLIDE PATH	APP-15
3.4	PITCH (ATTITUDE) CHANGES	APP-16
3.5	TO INTERCEPT AN ARC FROM A RADIAL	APP-16
3.6	TO INTERCEPT A RADIAL FROM AN ARC	APP-16
3.7	LEADPOINTS FOR TURNS TO HEADINGS	APP-16
3.8	TIME AND DISTANCE CALCULATIONS USING NDB	APP-16
3.9	ALTITUDE CORRECTIONS	APP-16
3.10	DRIFT CORRECTION	APP-16
3.11	INTERCEPTING NDB TRACKS	APP-17
3.12	TURN RADIUS FOR 30° BANK ANGLE	APP-17

APPENDIX 4:

References for Instrument Flying	APP-18	
4.1	SYMBOLS AND LEGENDS ON CHARTS	APP-18
4.2	GENERAL REFERENCE MATERIAL	APP-18
4.3	INSTRUMENT CRITERIA	APP-18
4.4	AIRSPACE INFORMATION	APP-18
4.5	METEOROLOGICAL INFORMATION	APP-18
4.6	REQUIREMENTS FOR AN INSTRUMENT RATING	APP-18
4.7	SIMULATORS AND GROUND TRAINING DEVICES	APP-18
4.8	NORTH ATLANTIC OPERATIONS	APP-18
4.9	AEROMEDICAL INFORMATION	APP-19
4.10	CAT II ILS APPROACH REQUIREMENTS	APP-19



LIST OF FIGURES

LIST OF FIGURES

P A R T 1

1-1	FROM AIR TO LUNG	1-2
1-2	OXYGEN CARRIAGE AND ALTITUDE.....	1-3
1-3	DECOMPRESSION AND TIMES OF USEFUL CONSCIOUSNESS	1-3
1-4	EFFECTS OF HYPERVENTILATION ON O2 LEVELS IN BRAIN AND BLOOD.....	1-4
1-5	RUNWAY VISUAL ILLUSION	1-6
1-6	PITCH-UP ILLUSION	1-6

P A R T 2

2-1	CONTINUOUS OR ANALOGUE DISPLAYS.....	2-2
2-2	COUNTER AND DRUM DISPLAYS.....	2-2
2-3	COMBINATION DISPLAY.....	2-3
2-4	COLOUR MARKINGS ON INSTRUMENTS.....	2-3
2-5	WARNING FLAGS	2-4
2-6A	"BASIC T" - LIGHT AIRCRAFT	2-4
2-6B	"BASIC T" - MODERN JET	2-4
2-6C	"BASIC T" - AIRSHIP	2-5
2-6D	"BASIC T" - VINTAGE TRANSPORT AIRCRAFT.....	2-5
2-7	VENTING OF A PITOT-STATIC SYSTEM	2-5
2-8	DUAL PITOT-STATIC SYSTEM.....	2-6
2-9	STATIC PORT	2-6
2-10	PITOT TUBE.....	2-6
2-11	OAT GUAGE	2-7
2-12	TYPES OF AIRSPEED INDICATORS.....	2-8
2-13	COMBINATION AIRSPEED/MACHMETER	2-9
2-14	PNEUMATIC ALTIMETER.....	2-9
2-15	TYPES OF ALTITUDE	2-9
2-16	COMPUTER INDICATOR ALTIMETER.....	2-11
2-17	RADAR ALTIMETER INDICATOR	2-11
2-18	ALTITUDE ALERTING SYSTEM	2-12
2-19	FACE OF VERTICAL SPEED INDICATOR	2-12
2-20	INSTANTANEOUS VERTICAL SPEED INDICATOR.....	2-12
2-21	ANGLE-OF-ATTACK SENSOR	2-14
2-22	ANGLE-OF-ATTACH INDICATOR.....	2-14
2-23	UNIVERSALLY MOUNTED GYRO.....	2-15
2-24	PRECESSION FORCE.....	2-15
2-25	TYPICAL SUCTION GUAGE	2-16
2-26	ATTITUDE INDICATOR.....	2-16
2-27	HEADING INDICATOR.....	2-17
2-28	COMPASS CONTROLLER.....	2-18
2-29	TURN AND SLIP INDICATOR.....	2-18
2-30	TURN CO-ORDINATOR.....	2-19
2-31	TYPICAL READINGS OF THE TURN CO-ORDINATOR	2-19
2-32	AIRCRAFT AT SAME BANK ANGLE, BUT DIFFERENT AIRSPEEDS	2-20
2-33	MAGNETIC COMPASS	2-21
2-34	ISOGONIC LINES	2-21
2-35	VFR AND IFR CHARTS SHOWING MAGNETIC VARIATION.....	2-21/22

2-36	CALCULATION OF MAGNETIC FROM TRUE.....	2-22
2-37	MAGNETIC DIP.....	2-22
2-38	COMPASS CORRECTION CARD.....	2-23
2-39	NORTHERLY TURNING ERROR.....	2-23
2-40	ACCELERATION ERROR.....	2-23
2-41	FLIGHT DIRECTOR INDICATOR.....	2-24
2-42	FLIGHT DIRECTOR MODE SELECTORS.....	2-24
2-43	HORIZONTAL SITUATION INDICATOR.....	2-25
2-44	EFIS PRIMARY FLIGHT DISPLAY.....	2-26
2-45	EFIS NAVIGATION DISPLAY.....	2-27
2-46	OTHER DATA ON EFIS DISPLAYS.....	2-27
2-47	TCAS CAUTION AREA.....	2-28
2-48	TCAS CLIMB RESOLUTION ADVISORY.....	2-29
2-49	TYPICAL HUD DISPLAY.....	2-30
2-50	WEATHER RADAR DISPLAY.....	2-31
2-51	STORMSCOPE.....	2-32
2-52	INSTRUMENT COMPARATOR.....	2-32
2-53	RADIO WAVE.....	2-33
2-54	TABLE OF RADIO FREQUENCIES.....	2-34
2-55	TRANSMISSION OF RADIO WAVES.....	2-35
2-56	NAVCOM CONTROL PANELS.....	2-38
2-57	NAVIGATION INDICATOR.....	2-39
2-58	TRACK BAR DEFLECTIONS.....	2-39
2-59	LEFT-RIGHT ENVELOPES.....	2-39
2-60	TO-FROM ENVELOPES.....	2-40
2-61	VOR INDICATIONS.....	2-40
2-62	VOR ORIENTATION.....	2-40
2-63	VOR POSITION FIX.....	2-41
2-64	BRACKETING A VOR RADIAL.....	2-41
2-65	VOR TIME CHECK.....	2-41
2-66	DIGITAL DME.....	2-42
2-67	SLANT RANGE MEASUREMENT.....	2-42
2-68	SEGMENTS OF A DME ARC.....	2-43
2-69	STAYING ON A DME ARC.....	2-43
2-70	FINAL APPROACH ARC.....	2-44
2-71	NDB CONTROL PANELS.....	2-44
2-72	FIXED CARD BEARING INDICATOR.....	2-46
2-73	NDB BEARINGS.....	2-46
2-74	HOMING TO AN NDB.....	2-46
2-75	BRACKETING AN NDB MAGNETIC BEARING.....	2-47
2-76	TRACKING FROM AN NDB.....	2-48
2-77	POSITION FIX BY NDB.....	2-48
2-78	RADIO MAGNETIC INDICATOR.....	2-49
2-79	RMI WITH VOR AND NDB INPUTS.....	2-49
2-80	TRACKING WITH AN RMI.....	2-49
2-81	ILS LOCALIZER SIGNAL PATTERN.....	2-50
2-82	ILS AREAS OF RELIABILITY.....	2-50
2-83	GLIDE SLOPE SIGNAL PATTERN.....	2-51
2-84	ILS STANDARD CHARACTERISTICS.....	2-52
2-85	MARKER BEACON LIGHTS.....	2-52
2-86	TYPICAL TRANSMISSOMETER INSTALLATION.....	2-53



2-87	MLS AZIMUTH AND ELEVATION COVERAGE	2-55
2-88	VOR/DME RNAV.....	2-56
2-89	AREA NAVIGATION ROUTE	2-57
2-90	LORAN-C COVERAGE.....	2-57
2-91	GPS SATELLITE ORBITS	2-58
2-92	GPS RECEIVER	2-59
2-93	INS CONTROL DISPLAY UNIT	2-60
2-94	INS MOUNTINGS	2-61
2-95	TYPICAL FMS CONTROL UNIT	2-62
2-96	CANADIAN RNAV ROUTES	2-62
2-97	ATTITUDE INDICATOR IS CENTRE OF SCAN	2-63
2-98	A STRAIGHT CLIMB ATTITUDE	2-64
2-99	APPROACH DESCENT ATTITUDE	2-65
2-100	45° BANK STEEP TURN	2-65
2-101	EXCESSIVELY LOW PITCH.....	2-67

P A R T 3

3-1	TYPICAL ATC RADAR SCREEN.....	3-9
3-2	APPROACH LIGHT LEGEND	3-10
3-3	VASIS AND PAPI	3-11
3-4	FINAL APPROACH VASIS PRESENTATION.....	3-12
3-5	CANADIAN DOMESTIC AIRSPACE	3-13
3-6	CONTROL AREAS	3-14
3-7	CONTROL AREA VERTICAL DIMENSIONS	3-14
3-8	LOW LEVEL AIRWAYS	3-15
3-9	STANDARD PRESSURE AND ALTIMETER SETTING REGIONS	3-16
3-10	AIRSPACE CLASSIFICATION	3-16
3-11	CMNPS AIRSPACE	3-19
3-12	NAT MNPS AIRSPACE	3-20
3-13	LATERAL SEPARATION OF AIRWAYS.....	3-22
3-14	OFF AIRWAY TRACKS (NON-RNAV)	3-22
3-15	TRACKS ON HIGH-LEVEL VOR AIRWAYS	3-23
3-16	TRACKS ON NDB AIRWAYS	3-23
3-17	HIGH LEVEL TRACKS - CHANGE OF DIRECTION	3-23

P A R T 4

4-1	DOMESTIC IFR FLIGHT PLAN	4-4
4-2	ICAO IFR FLIGHT PLAN	4-5
4-3	TORONTO DEPARTURE SEQUENCE	4-7
4-4	EDMONTON AERODROME CHART	4-8
4-5	TAXI HOLDING POSITION	4-9
4-6	TRANSPONDER CONTROL UNIT	4-9
4-7	SID - PILOT NAVIGATION.....	4-10
4-8	SID - VECTOR	4-11
4-9A	NOISE ABATEMENT PROCEDURE A.....	4-12
4-9B	NOISE ABATEMENT PROCEDURE B.....	4-12
4-10	CHANGES TO ENROUTE MINIMUM ALTITUDES	4-15
4-11	DESIGNATED MOUNTAINOUS REGIONS	4-17

4-12	STANDARD HOLDING PATTERN	4-19
4-13	HOLD ENTRY SECTORS.....	4-21
4-14	LEFT HAND PATTERN ENTRY	4-21
4-15	DME HOLDING PROCEDURE.....	4-21
4-16	PUBLISHED HOLDING PATTERNS	4-22
4-17	FIX FORMED BY INTERSECTION OF TWO RADIALS.....	4-24
4-18	STAR FOR CALGARY	4-25
4-19	PROFILE DESCENT FOR TORONTO.....	4-26
4-20	ALTITUDE CORRECTION CHART	4-33
4-21	REMOTE ALTIMETER SETTING	4-34
4-22	PUBLISHED TRANSITION TO APPROACH	4-34
4-23	DME ARC INTERCEPTION	4-35
4-24	TYPICAL APPROACH SEGMENTS.....	4-37
4-25	STRAIGHT-IN APPROACH CRITERIA.....	4-38
4-26	TYPICAL ILS APPROACH SEGMENTS	4-39
4-27	VARIATIONS OF THE PROCEDURE TURN	4-41
4-28	PROCEDURE TURN ENTRY SECTORS	4-42
4-29	PROCEDURE TURN AREAS.....	4-43
4-30	VISUAL MANOEUVERING AREA - CIRCLING APPROACH	4-48
4-31	CIRCLING APPROACH OPTIONS	4-48
4-32	CIRCLING RESTRICTIONS.....	4-49
4-33	NDB APPROACH	4-50
4-34	BEACON-ON-THE-FIELD APPROACH.....	4-51
4-35	VOR APPROACH TO FREDERICTON.....	4-52
4-36	VOR/DME APPROACH TO NORTH BAY	4-53
4-37	LOC (BC) APPROACH TO WINNIPEG	4-54
4-38	ILS CAT II APPROACH TO VANCOUVER	4-55
4-39	ILS APPROACH TO TORONTO	4-56
4-40	ON COURSE, ON GLIDEPATH	4-57
4-41	PAR TRAFFIC PATTERN	4-58
4-42	MULTI-SENSOR RNAV APPROACH.....	4-59
4-43	DIGITAL TRANSPONDER.....	4-63

P A R T 5

5-1	LANDING ON A RIG	5-4
5-2	ARCTIC OPERATIONS	5-5
5-3	TYPICAL HELICOPTER INSTRUMENT PANEL.....	5-7
5-4	GOING BACK TO SHORE	5-11
5-5	FAILED ATTITUDE INDICATOR.....	5-12
5-6	IFR/NIGHT AUTOROTATION PROCEDURE.....	5-13

P A R T 6

6-1	IFR GROUND TRAINING	6-2
6-2	RECOMMENDATION FOR INITIAL INSTRUMENT FLIGHT TEST	6-3
6-3	LEVEL II PILOT TRAINER.....	6-8
6-4	PILOT TRAINER EFIS DISPLAY	6-8
6-5	LEVEL II FLIGHT TRAINING DEVICE	6-9
6-6	LEVEL II CONVENTIONAL INSTRUMENTS AT NIGHT	6-10



P
A
R
T
O
N
E

**PHYSIOLOGICAL FACTORS RELATED
TO INSTRUMENT FLIGHT**

- 1.1 INTRODUCTION
- 1.2 OXYGEN AND ALTITUDE
- 1.3 OTHER EFFECTS
- 1.4 ORIENTATION AND DISORIENTATION

1.1 INTRODUCTION

Instrument flight, the ability to maintain control of an aircraft without outside visual references and often under adverse weather conditions, is one of the most skilled tasks a pilot can achieve. Such skill however is not a natural attribute and can only be gained by careful training, constant practice and a methodical approach. More than any other type of flying, it demands a suspension of belief in the physical sensations which we have learned to trust from birth and substituting learned responses to instrument displays. To cope with this transition we need to understand the body's response to a number of factors in our environment. These include hypoxia and hyperventilation, visual illusions, vestibular stimulation, spatial disorientation and the effects of fatigue, distraction, anxiety and fear. In this section of the manual the basic physiological information needed to approach this job with confidence will be presented, as well as some detailed guidance on how to overcome spatial disorientation.

1.2 OXYGEN AND ALTITUDE

1.2.1 THE ATMOSPHERE

The standard barometric pressure at ground level is 760 millimetres of mercury (mm. Hg) or 14.7 lbs. per sq. inch (psi). In this chapter we are going to use millimetres of mercury because it is normally used in physiology, but pounds per square inch will also be given because this is the calibration of most cabin pressure gauges.

Atmospheric pressure is the product of the weight of gasses surrounding the earth and their gravitational attraction. It is halved (380 mm. of mercury: 7.3 psi) at 18,000 ft., and becomes one quarter at 34,000 ft. The composition of the atmosphere however remains unchanged up to about 100,000 ft. It consists of 78% nitrogen, 21% oxygen and less than 1% carbon dioxide and traces of rare gasses. Nitrogen, although the major component, is an inert gas not involved in respiration.

1.2.2 FROM THE AIR TO THE TISSUES

The body requires oxygen in adequate quantities to metabolize (burn) proteins, fats, and carbohydrates to produce the energy for cell metabolism and body function. Such metabolism produces carbon dioxide and water. Carbon dioxide is excreted from the lungs and excess water is one of the waste materials.

To understand the process of respiration it is necessary to understand partial pressures. In a mixture of gasses under pressure, each gas will exert a pressure equal to its proportion in the mixture. This is its partial pressure. At sea level therefore the partial pressure of oxygen *in dry air* will be 21% x 760 or 160 mm. Hg. As we breathe the dry air is humidified in the nose and throat. This introduces the partial pressure of water vapour which is 47 mm. Hg., a figure constant with increasing altitude. Therefore the partial pressure of oxygen will be reduced to (760 - 47) x 21% or 150 mm. Hg. in the upper part of the lungs. (See Fig. 1-1).

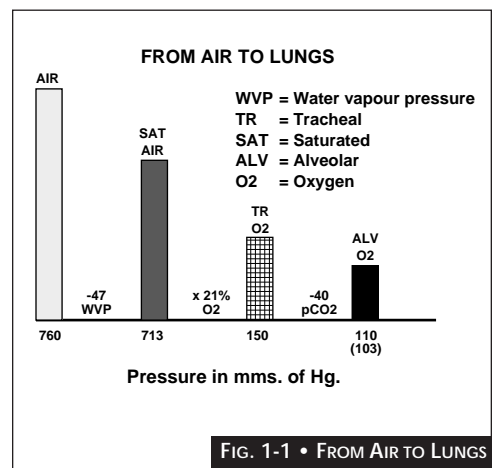

Air is carried to the lungs by a series of tubes call bronchi. These terminate in clumps of tiny air sacs or alveoli which arise from the end of the bronchi like bunches of grapes. Each air sac is small but their total surface area is almost equivalent to that of a tennis court. The alveoli are surrounded by numerous blood vessels and only a very thin membrane exists between the blood cells which will carry oxygen to the tissues and the oxygen in the alveoli.

The oxygen passes from the alveoli to the blood cells because of the higher oxygen pressure in the lung and is carried by Hemoglobin to the tissues.

As oxygen enters the cells, CO₂, the end product of metabolism, enters the blood and is carried to the lungs. There it enters into the alveoli and mixes with the O₂. The partial pressure of CO₂ in the alveolus is normally about 40 mm of Hg so the partial pressure of O₂ is reduced to 105-110 mm Hg (150 - 40).

**1.2.3
ALTITUDE EFFECTS**

So far we have been discussing the situation at sea level. As we ascend the total atmospheric pressure will decrease and so will the partial pressure of oxygen. Hemoglobin's ability to carry oxygen varies according to an S-shaped curve (Fig. 1-2). At the top of the curve, where the partial pressure of oxygen is high, oxygen saturation is high. At a partial oxygen pressure of 60 mm Hg however the saturation drops very sharply. 60 mm Hg is the partial pressure of oxygen at 10,000 ft. and above this altitude additional oxygen is required if the tissues are to be adequately oxygenated.

**1.2.4
HYPOXIA**

Hypoxia means a lack of adequate oxygen. In aviation this is usually due to a reduction in oxygen due to altitude (*hypoxic hypoxia*) or due to a lack of blood (*hemoglobin*) to carry the oxygen (*anemic hypoxia*). This can occur due to loss of blood from stomach ulcers, menstrual periods or blood donations. It can also be caused by the hemoglobin being blocked by carbon monoxide for which it has an affinity 210 times that which it has for oxygen. Heavy smokers may have from 5 - 8% of their hemoglobin blocked in this way meaning that their physiological altitude on the ground is already 5-7,000 ft.!

Hypoxia is insidious. This is its major danger. Even the minor degree of hypoxia experienced at 5,000 ft. reduces night and peripheral vision. Most pilots can operate safely up to a cabin altitude of 10-12 thousand ft. if they are in good health and are not smokers. Above that they will begin to experience impaired judgment and euphoria or lack of concern. Increasing hypoxia interferes with muscular coordination, mental calculation and reasoning power. Unconsciousness may occur before the pilot has become aware of the problem. Although different pilots may react differently to hypoxia, each individual pilot will go through the same stages on each occasion. Being exposed to hypoxia in a high altitude chamber therefore is a good method of learning your own reactions. It does not however mean that with unexpected hypoxia you will always be forewarned.

Although unconsciousness may come on quite

slowly, *the time of useful consciousness* is much shorter. This is the time in which we can recognize the problem and take measures to prevent it. It varies with the absolute cabin altitude and the rate of ascent. A sudden loss of cabin pressure at high altitude for example gives much less time for reaction than a slow ascent to the same altitude. Fig. 1-3 gives examples of these items and you will notice at above 50,000 ft. the time of useful consciousness is 15 seconds or less, the time it takes the blood to circulate once from the lungs to the brain.

**1.2.5
PREVENTION OF HYPOXIA**

Aircraft oxygen systems are of three types. The continuous flow system is the most common although it is wasteful of oxygen. Diluter demand systems vary the percentage of oxygen with increasing altitude by a barostat. At cabin altitudes above 30,000 ft. pressure demand regulators are required to ensure that the partial pressure of oxygen supplied to the lung is adequate.

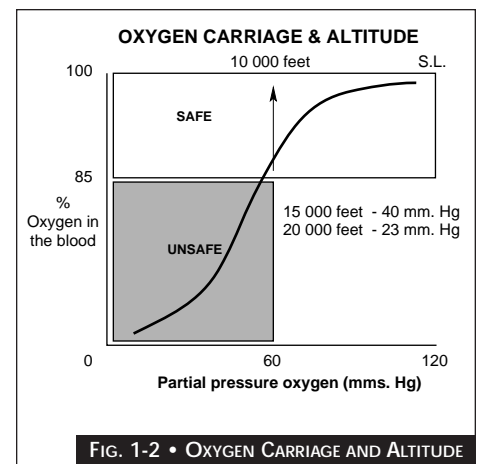

If available, oxygen should be used from the ground up at night if cabin altitude is going to be excessive. Above 10,000 ft. cabin altitude oxygen should always be available and the pilots should watch each other carefully for symptoms of breathlessness, increasing instrument errors, personality changes or evidence of poor judgement. Smokers will be at particular risk. Keep an eye on the cabin altitude, be aware of the dangers and you will not become a victim.

**1.2.6
HYPERVENTILATION**

The rate at which we breathe is regulated by the amount of carbon dioxide in the lungs and the blood. The normal breathing rate is 12-14 breaths per minute. If we breathe faster than this at rest we do

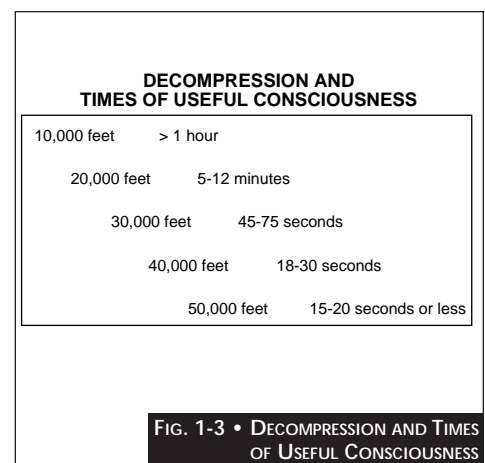

not increase the amount of oxygen in the blood - it is already at its maximum - but we decrease the carbon dioxide. This causes the blood to become more alkaline which in turn leads to constriction in the blood vessels of the head and neck reducing the blood supply - and so the oxygen supply - to the brain. Fig. 1-4 illustrates this.

Hyperventilation is an increase in the rate and depth of breathing and is caused by stress, anxiety, over concentration and fear. All these factors are in play with a difficult instrument approach in bad weather conditions. They are particularly common in inexperienced pilots who do not yet have confidence in their abilities. The breathing rate increases and symptoms begin to appear. These are a feeling of lightheadedness, a coldness around the mouth, tingling in the fingers and toes and later muscular spasms. Paradoxically there is often a feeling of breathlessness which worsens the situation.

It should be noted that there are several similarities in the symptoms of hypoxia and hyperventilation and that ultimately both of them cause a reduction of oxygen delivery to the brain. The symptoms of hyperventilation will disappear if the breathing is slowed or the breath is held temporarily. Often the victim will feel nausea and lightheadedness for some time afterwards.

1.2.7 TREATMENT OF HYPOXIA AND HYPERVENTILATION

Because the symptoms are similar the treatment must deal with both problems safely without the pilot having to make a diagnosis. This can be done as follows:

- 1/ *Below 10,000 ft.* - severe hypoxia is unlikely and the pilot should slow the breathing rate to 12 - 14 breaths per minute maximum. The breath may be held briefly but a valsalva manoeuvre should not be performed.
- 2/ *Above 10,000 ft.* - oxygen should be turned on and three or four deep breaths taken immediately. If the symptoms are due to hypoxia they will improve immediately. If they do not improve the rate of breathing should be controlled as above.

1.3 OTHER EFFECTS

1.3.1 THE EFFECTS OF ALCOHOL

Numerous experiments with experienced pilots, both in aircraft and simulators, demonstrate that alcohol and aviation don't mix. Although the Criminal Code limit for blood alcohol while operating a motor vehicle is at present 80 mg.%, levels as low as 10 mg.% have been shown to increase the number of pilot errors in routine instrument procedures. The effect on the organ of balance in the inner ear has been demonstrated to last as long as 24 hours when enough alcohol has been taken to produce a blood level of 100 mg.%. A hangover can be nearly as dangerous as the drinking itself. Remember, the *Air Regulations* prohibit acting as a crew member within 8 hours after the consumption of alcohol or while under the influence of any amount of alcohol.

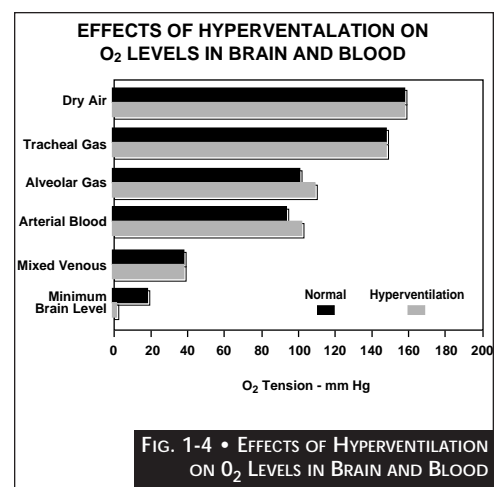

FIG. 1-4 • EFFECTS OF HYPERVENTILATION ON O₂ LEVELS IN BRAIN AND BLOOD

1.3.2 DRUGS

Illicit drugs and flying do not mix. If you fly, DO NOT USE ILLICIT DRUGS! Over the counter drugs such as cold cures, cough medicines, stomach medicines and allergy pills can have unpredictable effects which may be dangerous under visual conditions but become lethal when flying on instruments. Combination of drugs such as anti-depressants and nasal sprays may cause dangerous elevations of blood pressure and serious irregularities of the heart. Antihistamines and stomach pills are often additive in their effect and may cause sleepiness and depression. *Self medication in order to fly is always dangerous.* Don't be caught out!

1.3.3 FATIGUE

Fatigue, either chronic or acute, is a serious problem. Particularly when flying on instruments where accuracy and concentration

are vital, fatigue decreases attention, causes pilots to accept lower standards and interferes with critical judgement. It exaggerates the symptoms of all the other conditions we have discussed. It is increased by uncomfortable cockpit conditions, poor eating habits and poor physical conditioning. It may be caused by, or can itself cause, sleeplessness and depression. It is often at its most dangerous at the end of a trip in bad weather where all that remains is that final instrument letdown.

1.4 ORIENTATION AND DISORIENTATION

NOTE:

Most of this section is from the "Pilot's Guide to Medical Human Factors", Health and Welfare Canada, 1992. Reproduced with permission of the Minister of Supply and Services Canada, 1993.

1.4.1

INTRODUCTION

To most people orientation means being aware of their position in space (and time), but to the pilot orientation is sometimes just knowing which way is up. We rely on three systems for most of our orientation. These are the *kinesthetic sensors* (muscle - bone - joint sense), *vision* and the *vestibular (labyrinth) organs* in the inner ear. Vision is the dominant sense and is integrated with the vestibules whose prime role is to coordinate eye movements with body movements. This is achieved by multiple connections in the brain between the nerves that control the eyes and the organs of balance.

On the earth's surface our sense of orientation is remarkable. Even with the eyes closed we are (subconsciously) aware of the position of all our body parts. Standing, we can sense the nature of the surface underfoot. Sitting or lying, we sense the texture of surfaces and are able to make rapid movements to maintain balance if circumstances change.

In flight, orientation is more difficult because we are routinely exposed to forces other than gravity. A lot of training and experience is needed to develop the stored mental images required for this medium. Often, the sense we

have learned to trust on the ground gives us unreliable information in the air. In instrument meteorological conditions (IMC), we must rely on instruments instead of our instincts or we may become the victim of illusions (false impressions) and suffer *disorientation*. Although understanding the causes of disorientation will not avoid its occurrence, it does demystify it and allow us to cope with the consequences.

1.4.2

SENSORY ILLUSIONS

A. KINESTHETIC ILLUSIONS

Pilots use the phrase "flying by the seat of the pants" to describe the (subconscious) position sense used in flight on most days. When peripheral vision is limited, however, this sense becomes dangerously unreliable. Experience has taught us that gravity acts toward the centre of the earth and that the gravitational pull is "down". In an aircraft making a coordinated turn, the force we feel is actually centrifugal, acting out from the radius of turn. In a looping manoeuvre, the situation is even more bizarre because at the top of a loop the blindfolded pilot would sense the earth's pull as being up, not down. We need to develop a mental encyclopedia of unusual positions before we can begin to analyze correctly our kinesthetic sensations; even then they are often wrong. *The wise pilot knows that when kinesthetic sensations and the instruments disagree, the instruments are right!*

B. VISUAL ILLUSIONS

Vision may be separated into central and peripheral, although the two are always intimately connected. Central or focused vision is used for object recognition but peripheral vision is our main source of spatial orientation. Central vision illusions are usually misunderstandings of what we see; peripheral illusions are false impressions of movement or rotation.

Central visual illusions are often affected by expectancy. A pilot's judgement may be biased by previous experience and preconception. Pilots accustomed to flying from airfields surrounded by tall trees may misjudge their height on approaches in the Arctic where the trees are short and stunted. Pilots accustomed to a wide runway may feel uncomfortably high

on approach to a narrow runway. The narrow runway appears to be longer and farther away, causing a late flare and early touchdown. This effect is also responsible for the difficulty that inexperienced pilots have rounding out at night. Because the runway lights are outside the hard surface, they make the runway appear wider and the tendency is to round out high.

A good example of another central visual illusion is shown in Fig. 1-5. This is what a pilot sees on a normal 3° approach to two identical runways, one of which has a 2° uphill and the other a 2° downhill slope. The *uphill slope* presents a larger (taller) image at the retina which is interpreted as being high: the tendency is for a low approach to be flown and the aircraft may make contact before the round out has been completed. The *downhill slope* gives the impression of being too low, a flat approach is likely and round out may be made too high.

1. WHITE-OUT AND BLACK HOLES

White-out and black holes, both due to lack of contrast, cause many accidents. In *white-out* a layer of fresh snow on the ground merges with a white sky and indistinct horizon to *make depth perception practically impossible*. A similar effect may be caused by blowing snow, particularly in helicopters in the hover. Under white-out conditions, experienced pilots have flown aircraft into the ground while manoeuvring at low levels. Float plane pilots have similar problems making landings on glassy water. It is common practice for them to set up a constant, low-rate descent under these conditions rather than trying to estimate the height above the water.

During night visual approaches to runways in dark, featureless areas such as unlighted woods or over water, the lack of ambient clues to orientation interferes with depth perception. Such areas are known as *black holes*.

In these conditions, pilots often over-estimate their altitude, and, while concentrating on maintaining a constant visual angle of approach, describe an arc which results in premature contact with the ground. A frequent altimeter crosscheck is vital to avoid this problem.

Disorientation is also more common taking off at night in “black hole” conditions. It is imperative that pilots make the transition to instruments immediately upon take off and anticipate possible pitch up illusions (see Fig. 1-6)

2. FALSE HORIZONS

False perceptions of the horizontal can be confusing. Lining up with sloping cloud tops, particularly between layers, is not uncommon. At night, when flying over sparsely populated areas, ground lights and stars may be confused, giving a feeling of tilt or nose high attitude. A dimly lit, straight road in the distance can be mistaken for the horizon. Taking off into a black hole, the receding shoreline may be mistaken for the horizon, with disastrous results.

C. VECTIONAL ILLUSIONS

Illusions of false movement are common and difficult to ignore. Most car drivers have experienced a common *vectional illusion*. At a traffic light the neighbouring car creeps forward and you appear to be slipping backward. Many of us have jumped on the brakes with this sensation! Helicopter pilots, trying to hold a tight hover over water, feel they are moving because of the motion of the waves: over fields the movement of the grass in the rotor wash or blowing snow create a similar illusion. Illusions of vertical movement can be caused by raindrops running down the windscreen of an aircraft in cloud.

Angular vection occurs when there is rotation in the field of peripheral vision. Full-vision simulators make use of this by moving the scene outside the windscreen: the viewer’s sensation is that the simulator is rotating, not the scenery. The astonishing power of these illusions can be felt at an Imax cinema as the viewer drops from

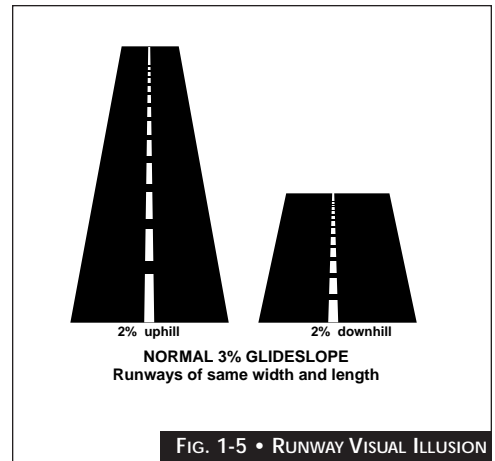

FIG. 1-5 • RUNWAY VISUAL ILLUSION

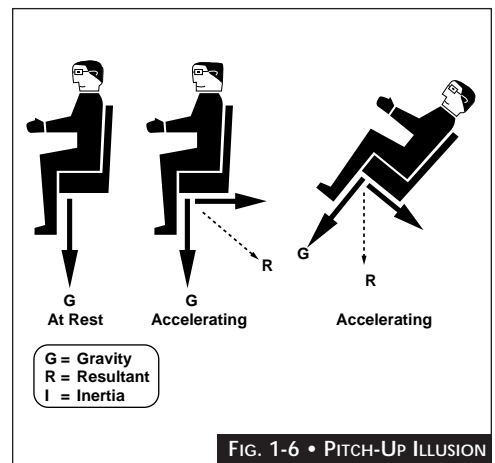

FIG. 1-6 • PITCH-UP ILLUSION

dizzying heights to the earth while actually firmly seated.

AUTOKINESIS

A small, fixed light viewed steadily at night appears to move. The movement is actually caused by the eyes losing fixation, drifting away and then jumping back to the target. Pilots, however, have altered course to avoid a collision with such lights, believing they are moving aircraft. The feeling can be overcome by deliberately looking away from the light and then back again. If lights are multiple, bright or large, this illusion is uncommon.

D. VESTIBULAR ILLUSIONS

Vestibular Illusions are the most complex and dangerous. The labyrinth contains two related organs; the *otoliths*, sensitive to *linear acceleration*, and the *semicircular canals*, sensitive to *angular acceleration*. Although both organs are similar in function, they will be described individually for simplicity.

1. *LINEAR ACCELERATIONS*

There are two *otoliths* in each inner ear, set at right angles to each other. One records accelerations in the horizontal plane, the other in the vertical plane. They are located in the common bulbus portion at the base of the semicircular canals and consist of hairlike fibres tipped by tiny calcium stones that project into the fluid (endolymph) filling the vestibular system. These hair fibres sway like weeds in a river current, swept by movements of the endolymph caused by acceleration forces. The movements generate nerve impulses which the brain interprets as changes of head or body position in the linear plane.

On the ground this system is accurate, but under the conditions of flight the otoliths can give rise to incorrect information. The *pitch-up illusion* is an example. (Fig. 1-6) When the aircraft is stationary on the tarmac, the otoliths sense only gravity, acting downward. When the aircraft accelerates for takeoff, a new force is sensed as the hair cells are swept backward by the inertia of the fluid. The brain resolves the two forces (gravity and acceleration) as a single resultant force acting downward and backward. We have learned to interpret

such a force as the head being tilted backwards, so the pilot feels that the nose of the aircraft is pitching up. In normal conditions the sensation is corrected by vision, but when a take-off is being made at night from a well lit airfield into a "black hole", it is difficult to ignore. The normal reaction to pitch-up is to push forward on the stick. Accident reports from such cases often state "...the aircraft struck the ground at a steep angle on the runway heading".

With deceleration a similar but opposite (*pitch-down*) illusion occurs. Sudden decelerations, such as those caused by dropping the speed brakes or lowering the flaps, sway the otoliths forward and the pilot feels that the nose of the aircraft is dropping. This illusion is most likely to occur on final approach at slow speed and the reaction of pulling back on the stick may cause a stall.

2. *ANGULAR ACCELERATIONS*

The *semicircular canals* are responsive to angular accelerations. Each canal is filled with a viscous fluid (endolymph) into which sensitive hair cells, similar to those in the otoliths, project which are affected by fluid movement. There are three canals in each (inner) ear, lying in the planes roughly corresponding to pitch, roll and yaw. Movement of the hair cells in the canals is recognized as rotation.

If a glass of water is rotated, because of inertia initially the water will move after the glass. In the same way, as we enter a turn, the fluid in the canal system lags behind the bony canal so the hair cells are displaced, telling us we have entered the turn. As the turn is continued the fluid begins to move and, after 10-30 seconds, the movement is synchronized with the walls of the canal and the deflected hair cells return to a neutral (upright) position. The feeling of turning will then disappear but, when the turn is completed and the aircraft levels out, inertia will cause the endolymph to continue to flow, although the canals are now still. The hair cells will be momentarily swept *in the opposite direction* and a sensation of an opposite turn will be felt which may last for 10-20 seconds. This is the *opposite turning illusion*.



3. GRAVEYARD SPIN

The opposite turning effect can cause a very dangerous illusion. An inexperienced pilot enters a spin *under instrument conditions*. After two or three turns the initial sensation of spinning will disappear. When the appropriate corrective action is taken, however, and the spin stops, the pilot will experience a sensation of turning in the opposite direction. If this is acted upon, the spin will be re-entered with disastrous results. Similarly in a spiral dive, pulling back on the stick without correcting for bank feels much like a full recovery and the inexperienced pilot whose sensation of turning is absent may believe the aircraft is level and that a recovery has been made. The result of this illusion has been called the “graveyard spin”.

4. COREOLIS EFFECTS

The *coreolis (excess G) illusion*, caused by inappropriate head movements, is the most confusing and dangerous of the vestibular illusions. Because the semicircular canals are interconnected, movement of fluid in two canals at the same time can cause fluid movements in the third canal. Here is an actual case:

“The pilot, taking off in marginal conditions, entered cloud. While climbing and accelerating a left turn was initiated and at the same time the pilot turned his head quickly downward, and to the right, to locate a switch. The semicircular canal which initially sensed the acceleration was repositioned by this head movement, and a second canal in a new plane was stimulated. The combined effects caused a movement of fluid in the third canal and the pilot experienced a violent sensation of tumbling. Because the vestibular organs also stabilize the eyes by reciprocal connections in the brain, focused vision was affected and to the pilot the whole scene, including the instruments, appeared to “rotate”.

Under such conditions it is extremely difficult to maintain control of an aircraft.

WARNING:

Turning the head sharply while in IMC, particularly if the movement is against the direction of turn, is extremely hazardous.

5. THE LEANS

The otoliths are very sensitive. Changes in acceleration as small as 0.01 G per second can be detected. The semicircular canals are less sensitive and, if the pilot is distracted, roll rates of up to 3° per second may go unnoticed. For example, a pilot, flying straight and level, is studying a chart or talking while the aircraft slowly drops one wing 15°. Becoming aware of the incorrect attitude, the pilot makes a quick recovery. Since the brain did not sense the original bank but now senses the correction, the pilot will feel that the aircraft is in a 15° bank in the direction of the recovery, even though the instruments clearly indicated level flight. The feeling is so compelling that the pilot leans toward the opposite side of the aircraft to maintain a feeling of balance. The feeling is disturbing rather than dangerous but extremely common. Usually, it is short lasting but one well documented case in cloud lasted for over an hour.

1.4.3

GENERAL FACTORS

It is extremely difficult to mimic these conditions in the air, even under the hood, but most can be demonstrated in simulators. The head-turning (excess G) phenomenon can be demonstrated by spinning a blindfolded subject on a piano stool while head movements are made. This must be demonstrated with great care, however, as the subject can easily be thrown from the stool by the body’s righting reaction.

Disorientation is not a disease or an illness; even experienced pilots suffer from it. Fatigue, inattention, alcohol or a hang-over all make disorientation more likely to occur. Flying with a cold can also cause problems if one ear clears before the other on ascent. The sudden difference in pressure in the two inner ears may produce a short-lasting but acute sense of

vertigo (spinning) which is known as *alternobaric vertigo*.

1.4.4

PREVENTING DISORIENTATION

Spatial disorientation is not totally preventable and can and does happen to anyone. However, perhaps the most important prevention tool is to know about the various misleading sensations and to learn how to avoid them when possible. This involves awareness/anticipation, experience and training, and the pilot's own capabilities and limitations.

A. AWARENESS/ANTICIPATION

Adequate pre-flight preparation, including knowledge of the weather you are going to encounter during your flight, is very important. Prepare alternate plans for poor weather conditions, and carefully review any factors affecting approaches or landings. Avoid physiological factors that influence your ability to cope with disorientation like alcohol, fatigue, stress or poor nutrition.

B. EXPERIENCE/TRAINING

The recency and overall level of experience play tremendous roles in a pilot's ability to fly well on instruments. Instrument flying is a skill which erodes with time; only frequent use of this skill will allow you to maintain it at your highest - therefore safest - level. *Unless you are competent and current, avoid flying IMC.*

A *good instrument scan* helps in preventing disorientation. It is also important to scan at the right time. It is a good rule to force yourself to scan more frequently than feels comfortable, especially when some of the warning factors for spatial disorientation are present.

C. PILOT KNOWLEDGE

As a pilot you must know your capabilities and limitations. You should establish a mental checklist for yourself, and adjust your flight accordingly. Establish priorities and remember that *basic flying tasks come first*. Do not let over confidence, excessive motivation or peer pressure interfere with good judgement.

1.4.5

OVERCOMING DISORIENTATION

The following are standard procedures and recommendations to be used if you think you are suffering from spatial disorientation in any form:

A. GET ON THE INSTRUMENTS

Increase your scan, understand what the instruments are telling you, and *believe them*, regardless of your sensations. Concentrating on the instruments and making them "*read right*" is a definite way to bring the aircraft under control when disorientation strikes. It will also shorten the effects of the symptoms of disorientation. Delay intuitive actions until confirmed by checking instruments. Then stay on instruments, but not to the point of fixation. Make them "*read right*" by forcing yourself to establish and maintain a rigorous instrument scan. Do not try to transition back and forth between instruments and visual references.

B. RESTRICT HEAD MOVEMENTS

Minimize head movements to establish a constant frame of reference from the neck. This will tend to reduce the effects of disorientation and shorten the recovery time.

C. FLY STRAIGHT AND LEVEL

Once you obtain straight and level flight using your instruments, avoid further manoeuvres until you have regained full orientation and sensory illusions are minimized. If necessary, declare an emergency.

D. USE COCKPIT RESOURCES

If available, use another crew member to confirm and monitor flight parameters. If you become disorientated for any reason, transfer control to the other pilot; then, get on instruments to regain orientation. Seldom will both crew members experience disorientation at the same time. If the aircraft has an autopilot, use it!



P
A
R
T

T
W
O

**INSTRUMENTATION, NAVIGATION SYSTEMS
AND BASIC INSTRUMENT FLYING**

- 2.1 INSTRUMENTS
- 2.2 NAVIGATION SYSTEMS
- 2.3 BASIC INSTRUMENT FLYING

2.1 INSTRUMENTS

2.1.1 INTRODUCTION

A. AIRCRAFT INSTRUMENTATION

The cockpit instruments in any aircraft can be described in a variety of ways. They may, for example, be grouped into the following four broad, functional categories:

1. **CONTROL INSTRUMENTS:** Information relating to the aircraft's attitude and power being supplied is displayed on the control instruments. Includes attitude indicator and engine control instruments.
2. **PERFORMANCE INSTRUMENTS:** Information relating to the performance of the aircraft as determined by the airspeed indicator, altimeter, vertical speed indicator, heading indicator, magnetic compass and turn coordinator or turn and bank indicator..
3. **NAVIGATION INSTRUMENTS:** Information relating to the aircraft's position in relation to a particular NAVAID or reference point is presented on the navigation instruments. Can include NDB, VOR, ILS, GPS, INS, Loran C and Omega.
4. **MISCELLANEOUS INSTRUMENTS:** These instruments present information relating to:
 - a/ the condition of aircraft systems (hydraulic, electrical, pressurization, oxygen);
 - b/ the position of aircraft ancillaries and control surfaces (landing gear, flaps, trim systems).

A particular instrument or display may also be classified into one of the following types, depending upon how it presents the information to the pilot:

1. **CONTINUOUS OR ANALOG:** These displays (See Fig. 2-1) are found in most aircraft instruments in current usage. The simplest form consists of a circular scale swept by a single pointer, which allows the pilot to detect trends or changes from the relative position of the pointer when a precise reading is not always necessary.

2. **DIGITAL:** Digital displays (See Fig. 2-2) are ideal for the presentation of specific numerical values and are normally composed of some form or combination of:
 - a/ **ELECTRICAL** - usually LEDs or lights;
 - b/ **COUNTER** - a wheel marked with consecutive numbers which move in discrete steps from one number to the next at given change-over points; and
 - c/ **DRUM** - a wheel marked with consecutive numbers or with a scale, which rotates steadily for a continuous output.
3. **COMBINATION:** Combines digital displays for precise readings with analog displays for trend information. Most commonly associated with EFIS. (See Fig. 2-3)
4. **SYMBOLIC:** Used to display information of a qualitative nature and to show trends. Symbolic displays generally attempt to show the graphic relationship between the symbols presented and the information to be assimilated by the pilot. An HSI is an example.

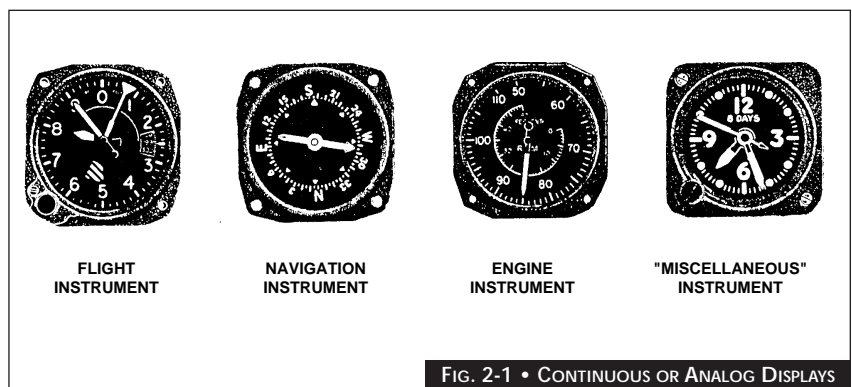

FIG. 2-1 • CONTINUOUS OR ANALOG DISPLAYS

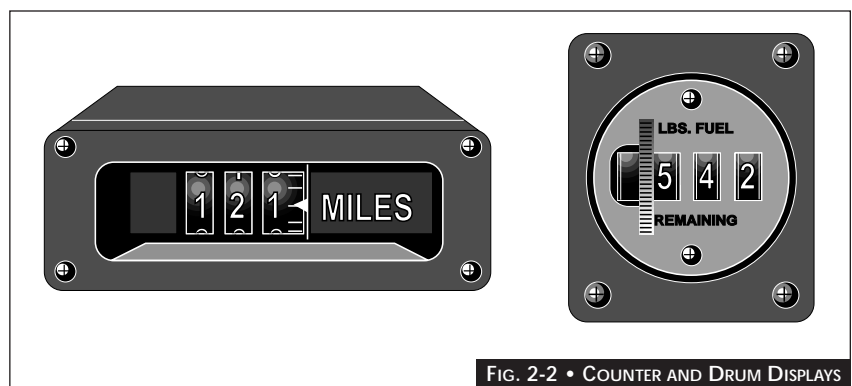

FIG. 2-2 • COUNTER AND DRUM DISPLAYS

5. **PICTORIAL:** Pictorial displays process navigational inputs and convert them to create a visual display of the outside world totally within the cockpit. An EFIS navigational display is an example.

Aircraft instruments may also be described according to the following service they provide to the pilot:

1. **SITUATION INFORMATION:** General orientation is provided. The pilot is told what the aircraft is doing, or where it is. The pilot must interpret all available information and combine it with his or her own knowledge and experience to plan and execute all necessary corrections. An example of this type of instrument would be an attitude indicator.
2. **COMMAND INFORMATION:** The pilot is directed to his next course of action. This is usually done by the presentation of an error signal which must be rectified. Generally, the error signals are derived by the routing of several situation information signals through a precisely programmed computer. A flight director falls into this category.
3. **STATUS INFORMATION:** Additional data received by the pilot which are not directly concerned with the actual control of the aircraft. Quantity gauges such as oxygen and fuel would be included as a part of status information.

3. **CHECK READING:** Verifying that a desired indication or value is being properly maintained. An example is the normal cross-checking of an altimeter during stable, level flight.

4. **SETTING:** An indicator is adjusted to a desired value, i.e., setting power, or to match another indicator, i.e., engine synchronization.

5. **TRACKING:** Tracking is the intermittent or continual adjustment of an instrument:

- a/ to maintain a desired indication or value (compensatory tracking), i.e., the adjustment of the attitude indicator pitch bar for level-flight reference, following a large airspeed change; or
- b/ to follow a moving reference (pursuit tracking), i.e., the track deviation bar of an HSI (Horizontal Situation Indicator) when intercepting the desired track.

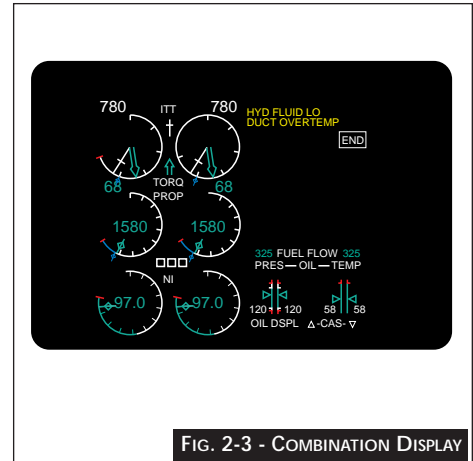

FIG. 2-3 - COMBINATION DISPLAY



FIG. 2-4 • COLOUR MARKINGS ON INSTRUMENTS

The manner in which instruments may be interpreted, under widely varying circumstances, can also be categorized as in the following:

1. **QUANTITATIVE READING:** Quantitative reading is the determination of an exact numerical value, i.e. the reading of the precise indicated altitude on an altimeter.
2. **QUALITATIVE READING:** Judging the approximate value, the deviation from a desired indication or value, and the direction of the indication. For example, the cross-checking of an altimeter after an inadvertent nose down pitch change shows the aircraft to be 50 feet below the desired cruising altitude and still slowly descending.

B. INSTRUMENT RANGE MARKINGS

Coloured markings are used on many instruments to identify operating ranges:

COLOUR	MEANING	REMARKS
GREEN	SAFE	Normally in the form of arcs which depict the normal operating range
YELLOW	CAUTION	To show limited operation or a precautionary range
RED	DANGER	Arcs normally show a range where operation is prohibited, while radial lines depict minimum and maximum safe operating limits.

C. LIGHTING

White lighting is the desired standard for cockpits and instruments, combined with grey cockpit interiors. Some of the advantages of this combination are:

- 1/ white lighting permits the unrestricted use of colour;
- 2/ warning indicators become more prominent; and
- 3/ the mounting of black instrument cases against a grey background emphasizes the size and shape of individual instruments.

Individual instruments currently in use may be lighted by:

- 1/ integral lighting, which is built right into the instrument;
- 2/ ring, eyebrow, or post lighting, all of which are fitted to the exterior of the instrument case; and
- 3/ various types of flood-lighting.

D. INSTRUMENT MALFUNCTIONS

Some instruments incorporate warning or OFF flags, which come into view for one of the following reasons:

- 1/ an instrument or system has lost all or some electrical power;
- 2/ the rotor in a gyroscopic unit is operating at too low a speed; or
- 3/ the signal received by a navigational instrument is either non-existent or too weak.

NOTE:

The absence of warning flags from a display is no guarantee of correct instrument function. Although any instrument is subject to failure or malfunction, most have no device to indicate serviceability. The pilot must continually monitor to detect any abnormal indication, and then attempt to determine whether the instrument itself is at fault.

E. "BASIC T" INSTRUMENT PANEL

The internationally-agreed standard layout for primary flight instruments is the "Basic T". The "Basic T" features a compact grouping to reduce the over-all scan, and, since the eye scans more

efficiently from side to side, the primary grouping is horizontal. Fig. 2-6 A-D show examples of the "Basic T" in various types of aircraft.

Components of the "Basic T" are:

1. *ATTITUDE INDICATOR:*
 - a/ the attitude indicator is located in prime top central position;
 - b/ a combination of a



FIG. 2-5 • WARNING FLAGS



FIG. 2-6A • "BASIC T" - LIGHT AIRCRAFT



FIG. 2-6B • "BASIC T" - MODERN JET

moving horizon and fixed aircraft symbol is ideal, since the instrument and earth horizon are then always aligned during transitions; and

- c/ the attitude indicator may incorporate the turn-and-slip indicator plus command information.

2. **AIRPEED INDICATOR:**

- a/ the airspeed indicator is located to the left of the attitude indicator; and
- b/ it could be fitted with critical speed markings and/or possibly be oriented to provide visual cues (i.e., approach speed in the 3 o'clock position closest to the attitude reference).

3. **ALTIMETER:**

- a/ the altimeter is located to the right of the attitude indicator; and
- b/ a radio or radar altimeter should be located nearby when fitted.

4. **HEADING REFERENCE:**

- a/ this is located immediately below the attitude indicator; and
- b/ HSI is the ideal equipment; when not fitted, this space could be allotted to the RMI/DRMI.

5. **VERTICAL-SPEED INDICATOR:**

The vertical-speed indicator is located below the altimeter.

6. **TRACK INDICATOR:**

The track indicator is located below the airspeed indicator when the aircraft is not HSI-equipped.

NOTE:

Older or modified aircraft may not conform to this standard "Basic T". Pilots should use caution when changing from one aircraft to another for instrument flight.

2.1.2

PITOT-STATIC SYSTEM AND INSTRUMENTS

A. **GENERAL**

Aircraft constantly encounter atmosphere pressure changes as they climb, descend, accelerate or decelerate. The pitot-static system - sensitive to airspeed, altitude, and rates of altitude change - provides the pressure

information displayed on cabin instrumentation.

An outside air temperature sensor must be installed for air data systems.

The airspeed indicator is vented

to both pitot and static lines. The airspeed indicator reacts to changes between pitot air and static air. The altimeter and vertical speed indicator, however, require venting to only the static line

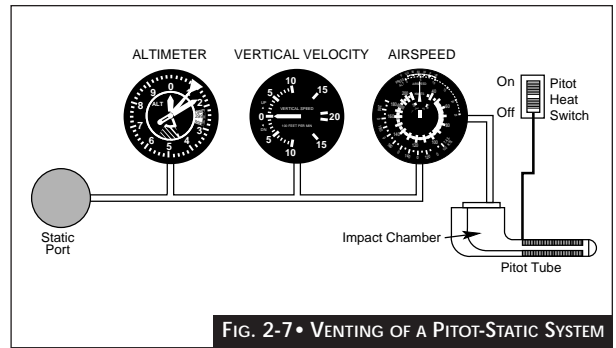

FIG. 2-7 • VENTING OF A PITOT-STATIC SYSTEM



FIG. 2-6C • "BASIC T" - AIRSHIP



FIG. 2-6D • "BASIC T" - VINTAGE TRANSPORT AIRCRAFT

(Fig. 2-7). The system shown employs a heated pitot tube to prevent ice formation, a necessary feature for flight in instrument conditions.

B. PRINCIPLES

A pitot-static system supplies air pressure sensations directly to differential pressure flight instruments for the measurement of aircraft speed and altitude, as shown in Fig. 2-8.

The pitot tube is a ram air pressure-sensing device usually mounted near the leading edge of the wing and connected to the back of the airspeed indicator case by a tube. Due to its location, the pitot tube is susceptible to foreign matter such as dirt, water and ice. Aircraft used for instrument flight must have a heated pitot tube (Fig. 2-7) to reduce the possibility of ice obstructing the intake port. Because foreign matter may enter the pitot tube, *pilots should carefully inspect the pitot tube and test the heating element before flight.*

The static line vents the pitot-static instruments to the outside, or ambient, air pressure through the static port. The static port (Fig. 2-9) may be located in various places on different types of aircraft and more than one port may be used. Regardless of location, the port is always positioned so the plane of the opening is parallel to the relative air flow. By comparison, the plane of the pitot tube opening is nearly perpendicular to the relative wind. The pressure sensed at the static ports is transferred to the cabin instruments by a tube.

Because moisture condensation within pitot and static lines can cause erroneous instrument readings, a condensation sump is usually provided in the system. In addition, some pitot tubes (Fig. 2-10) have condensation drains. Aircraft used for instrument flight have an *alternate static source* because the static line can freeze shut or the static port can ice over.

Generally, on non pressurized aircraft, the alternate static source is in the cabin. When used, this source introduces some error in the instruments because the cabin air pressure is lower than outside air pressure due to airflow over the cabin. Airspeeds and altitudes read higher than normal. The vertical airspeed indicator shows a momentary climb as the alternate static source is opened, followed by

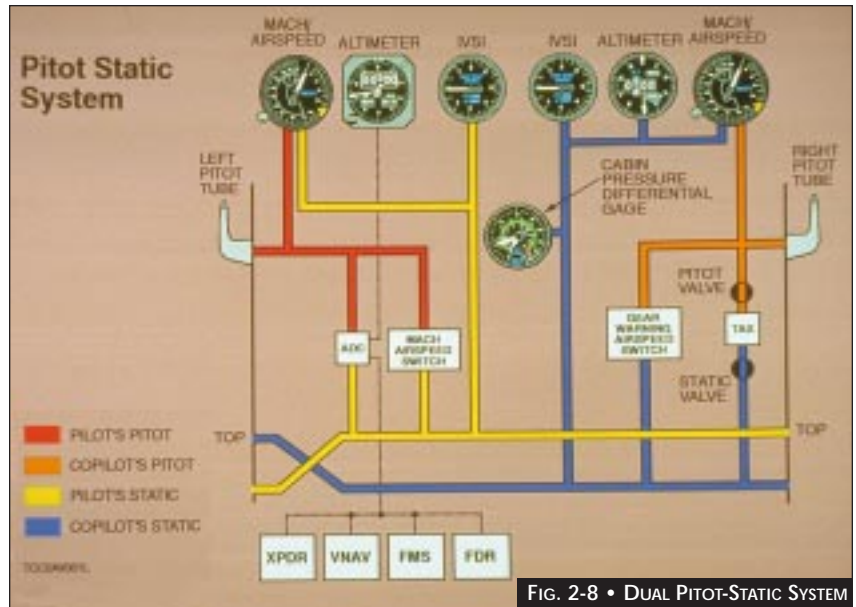

FIG. 2-8 • DUAL PITOT-STATIC SYSTEM

stabilization and normal readings thereafter.

An outside air temperature sensor is usually a probe mounted to a point along the aircraft's longitudinal axis. The probe compresses the impaction air to zero speed, thus producing and measuring a stagnation temperature. It is shielded to reduce errors from solar radiation and thermal radiation to the relative airflow.

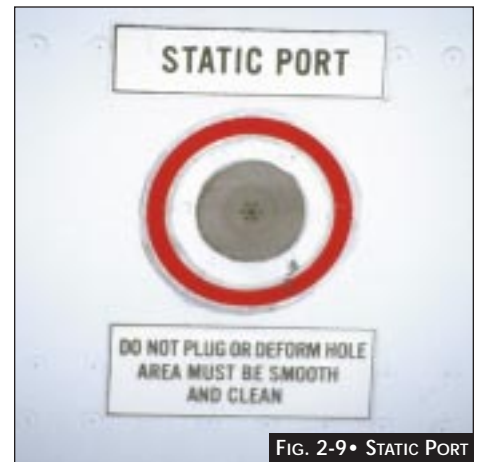

FIG. 2-9 • STATIC PORT

C. INHERENT ERRORS

Varying magnitudes of the errors described here are present within the pitot-static system of any aircraft. Full details of a particular system must, therefore, be obtained from Aircraft Flight Manuals.

DENSITY ERROR:

Density error results from variations in atmospheric pressure and temperature. It must normally be determined with the aid of a flight computer (solve for Density and/or True Altitude of True Airspeed). Airspeed, mach indicators and pressure altimeters are affected by density error.

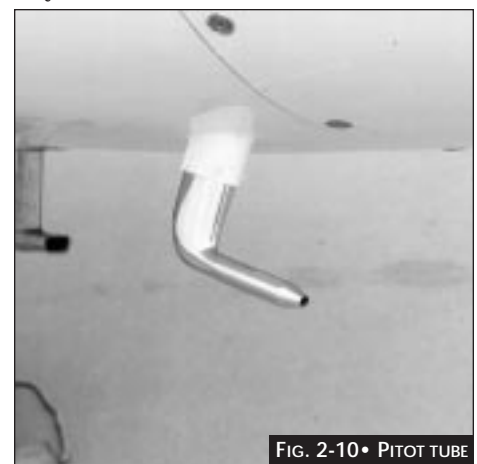

FIG. 2-10 • PITOT TUBE

POSITION (INSTALLATION) ERROR:

This error results from incorrect pressure sensations caused by disturbed airflow around the pitot head and/or static vents. It may be either a positive or negative value, which varies according to:

- a/ airspeed;
- b/ angle of attack;
- c/ aircraft weight;
- d/ acceleration;
- e/ aircraft configuration; and
- f/ rotor downwash (helicopters).

Position error can be sub-divided into two components:

- 1/ *FIXED* - a set of values common to all aircraft of a given type (which can be determined from correction charts in the appropriate AFM);
- 2/ *VARIABLE* - a random set of overstresses, deformed skin panels, etc.

Airspeed, mach indicators and pressure altimeters are affected by position error.

COMPRESSIBILITY ERROR:

Compressibility error results from air being compressed in the pitot tube inlet, generally at altitudes above 10,000 feet and calibrated airspeed in excess of 200 knots. It generally produces indicated airspeed readings that are too high.

HYSTERESIS:

Hysteresis results from the imperfect elasticity of aneroid capsules and springs which tend to retain a given shape even though the external forces have changed. It is present during rapid altitude changes and for a short duration thereafter. Hysteresis affects pressure altimeters.

REVERSAL ERROR:

Reversal error results from induced false static pressure sensations caused by large or abrupt pitch changes which give a momentary indication in the opposite direction. It affects pressure altimeters and vertical-speed indicators.

D. SYSTEM MALFUNCTIONS

Various blockages of the pitot-static system can occur. The most common problems are:

- 1/ the pitot heat has not been activated, or has failed, and ice has formed in the intake;
- 2/ ice has accreted over static vents; or
- 3/ foreign objects have entered the system.

Blockage effects may be categorized as follows:

INSTRUMENT	STATIC BLOCKAGE	PITOT BLOCKAGE
ALTIMETER	"Freezes" at constant value	n/a
VERTICAL-SPEED INDICATOR	"Freezes" at zero	n/a
AIRSPPEED INDICATOR	Under-reads in climb and over-reads in descent	Over-reads in climb and under-reads in descent

CAUTION:

Pitot icing can occur at a relatively slow rate, causing a gradual reduction in pitot pressure. This results in a slow decrease in indicated airspeed rather than a frozen condition.

E. PILOT CHECKS

Pilot checks of the pitot-static system relating to specific instruments are covered in the appropriate sections. In general:

- 1/ ensure the removal of protective covers;
- 2/ confirm the functioning of the heater element; and
- 3/ visually inspect for:
 - a/ bent or loose pitot head mounting,
 - b/ fuselage deformations in the vicinity of the static vents, and
 - c/ foreign material in the pitot tube or static vents.



FIG. 2-11 • OAT GAUGE

F. PITOT-STATIC INSTRUMENTS

1. **AIRPEED INDICATOR AND V SPEEDS:** The pilot can receive a great deal of information from the airspeed indicator. Regardless of temperature or altitude, the airspeed indication is the same for specific aircraft performance. For example, if the aircraft has an indicated stalling speed of 62 kts at sea level, it will stall at the same indicated airspeed at 5,000 ft (all other factors being equal). Vented to both pitot and static lines, the airspeed indicator reacts to any change between *ram* (dynamic) air pressure and *static* (passive) air pressure. The greater the differential between these two readings, the greater the airspeed.

The instrument (Fig. 2-12, 2-12A) contains a single pressure diaphragm connected to the pitot line; the airtight case surrounding the diaphragm is vented to the static line. Pitot ram air expands the diaphragm proportional to speed, and diaphragm movement is transferred to the needle on the instrument face by means of a mechanical linkage.

BASIC AIRCRAFT SPEEDS

Indicated airspeed (IAS) reflects true airspeed (TAS) only when ICAO standard atmospheric conditions prevail, i.e., temperature 15°C, and pressure of 29.92 in. Hg at sea level. Calibrated airspeed (CAS) corrects the indicated airspeed for errors primarily resulting from the position of the static source and, to a much lesser degree, from pitot tube locations. The major errors are mainly due to differences in airflow over the static port at varying angles of attack. The errors usually are greatest in the low and high speed ranges and smallest in normal operating speeds. Calibrated airspeed tables correct the whole range of indicated airspeed for these installation errors and can be found in the aircraft flight manual.

The flight computer calculates the TAS by converting the IAS under actual conditions to a standard temperature and pressure. This conversion is necessary because the pitot-static system operates accurately only at the standard conditions mentioned above.

By using a flight computer, the pilot can calculate the TAS by applying the actual outside air temperature to the pressure altitude. Some airspeed indicators incorporate a TAS computer (Fig. 2-4) enabling the pilot to read TAS directly from the outermost scale on the face of the indicator.

AIRPEED COLOUR MARKINGS AND V SPEEDS

The face of the airspeed indicator on General Aviation (GA) aircraft usually shows both statute and nautical miles per hour (Fig. 2-4). It also has coloured arcs to show important speed limits and operating ranges, along with various V speeds relating to the colour markings or airspeed bugs on the instrument. (see Fig. 2-12 and 2-12A)



FIG. 2-12 • TYPES OF AIRSPEED INDICATOR



FIG. 2-12A • TYPES OF AIRSPEED INDICATOR

V SPEEDS	DEFINITIONS
V _{SI}	velocity: stall, power off, clean
V _{SO}	velocity: stall, landing configuration
V _{FE}	velocity: maximum for flap operation
V _{LO}	velocity: maximum for gear operation
V _X	velocity: best angle to climb at gross weight
V _Y	velocity: best rate of climb at gross weight
V _A	velocity: manoeuvring
V _{NE}	velocity: never exceed
V _{MC}	velocity: minimum control speed

Pilots should remember that all of these markings and airspeed limitations on the instrument are expressed in calibrated airspeeds. Other V speeds can be found in the *AIP*, General chapter.

The *white arc* on the airspeed indicator designates the flap operating range. The *green arc* shows the normal operating range, and the *yellow (caution) arc* signifies the smooth air cruising range. A *red line* usually indicates the Vne (never exceed) speed. Pilots should never use the caution range during turbulent atmospheric conditions. The aircraft manual defines additional V speeds not shown on the airspeed indicator.

Some airspeed indicators incorporate a *Machmeter* for high speed operations. It provides a continuous indication of the ratio of an aircraft's airspeed to the local speed of sound. (Fig. 2-13). Some airspeed indicators also incorporate a maximum allowable airspeed pointer which continuously displays the maximum allowable airspeed for a particular aircraft (Fig. 2-12A).

2. **ALTIMETER:** The altimeter senses the normal decrease in air pressure that accompanies an increase in altitude. The airtight instrument case is vented to the static port. With an increase in altitude, the air pressure within the case decreases and a sealed aneroid barometer (bellows) within the case expands. The barometer movement is transferred to the indicator (Fig. 2-14), calibrated in feet and displayed with two or three pointers. Different types of indicators display indicated altitude in a variety of ways.

Generally, this instrument responds immediately to altitude changes. During climbs and descents, however, the altimeter may lag behind the aircraft's actual altitude. For this reason, some lead is necessary when levelling off to compensate for this characteristic. A simple rule of thumb is to lead the desired level-off altitude by 10% of the vertical velocity.

An indication of feet above sea level is possible only if the current altimeter setting is in the window on the face of the instrument.

Caution should be exercised when reading the thousands of feet pointer or indicator of the altimeter as it can often be misleading.

ALTIMETER SETTING WINDOW

The altimeter is a calibration unit because the aneroid barometer cannot differentiate between actual altitude changes and changes in the barometric pressure of the air mass itself. The altimeter setting window (Fig. 2-14) allows the pilot to set the current altimeter setting on a small scale, calibrated in inches of mercury. The

indicator responds only to altitude changes, as long as the altimeter setting is accurate and the pilot "updates" the current setting as new reports come in.

An aircraft altimeter which has the current altimeter setting applied to the subscale *should not* have an error of more than ± 50 ft when compared on the ground against a known aerodrome/runway elevation. Altimeter initial certification requirements are ± 20 ft. at sea level increasing to ± 230 ft. at 40,000 ft. If the error is more than ± 50 ft. the accuracy of the altimeter is questionable and the problem should be investigated prior to flight. Investigation could include updating the altimeter setting, comparing with other altimeters, adjusting for height of location of altimeter and many other possibilities.



FIG. 2-13 • COMBINATION AIRSPEED/MACHMETER



FIG. 2-14 • PNEUMATIC ALTIMETER

ALTITUDE DEFINITIONS

Vertical separation of aircraft is based on local altimeter settings. The definitions below are important because pressure variations en route require changes in the altimeter setting, and TAS computations are based on temperature and pressure conversions. See Fig. 2-15.

- a/ *Indicated altitude* is read directly from the altimeter when set to current barometric pressure.
- b/ *Pressure altitude* is read from the altimeter

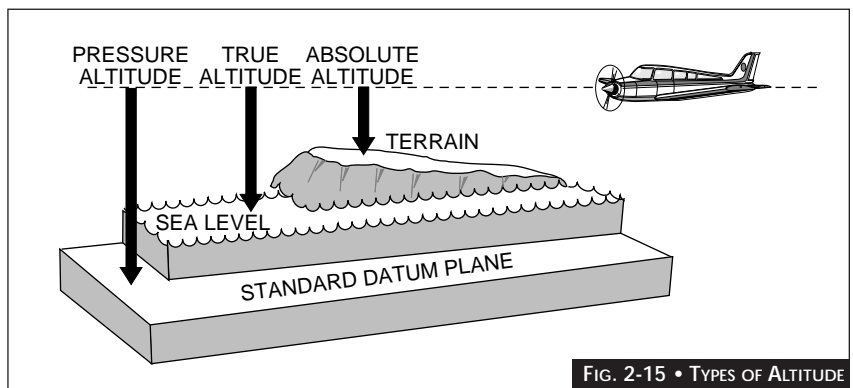

FIG. 2-15 • TYPES OF ALTITUDE



when set to the standard barometric pressure of 29.92 in. Hg.

- c/ *Density altitude* is the pressure altitude corrected for non-standard temperature.
- d/ *True altitude* is the exact height above mean sea level.
- e/ *Absolute altitude* is the actual height above the earth's surface.

INHERENT ERRORS

The pneumatic altimeter is subject to the following errors:

- a/ *Position Error*: In some installations, position error can be of considerable magnitude.
- b/ *Scale Error*: Commonly referred to as instrument error, scale error is caused by the aneroids not assuming the precise size designed for a particular pressure difference. This error is irregular throughout the range of the instrument (it might be -30 feet at 1,000 feet and +50 feet at 10,000 feet). The tolerances for this error became larger as the measured altitude is increased.
- c/ *Mechanical Error*: Mechanical error is caused by misalignment or slippage in the gears and linkage connecting the aneroids to the display, or in the shaft of the barosetting knob.
- d/ *Density Error*: ICAO Standard Atmosphere conditions seldom prevail, and the resulting density error is only partially offset by the diligent application of correct altimeter settings (station or standard pressure). It can generally be disregarded for Air Traffic Control purposes, since all pressure altimeters in close proximity react in the same way, and vertical separation is maintained.

NOTE:

Whenever terrain clearance is a factor, the effects of density error should be computed and the necessary correction applied, especially during very cold temperatures. See AIP for detailed method to calculate true altitude, or CAP GEN for altitude correction charts

- e/ *Hysteresis*: This error is a lag in the altitude indications caused by the elastic properties of the materials used in the aneroids. It occurs when an aircraft initiates a large, rapid altitude change or an abrupt level-off

from a rapid climb or descent. It takes a period of time for the aneroids to catch up with the new pressure environment; hence, a lag in indications. This error has been significantly reduced in modern altimeters and is considered negligible at normal rates of descent for jet aircraft.

- f/ *Reversal Error*: During abrupt or rapid altitude changes, reversal error occurs; it is only momentary in duration.

ALTIMETERS ARE SUBJECT TO THE FOLLOWING EFFECTS:

- a/ *Effect of Mountains*: Winds which are deflected around large single mountain peaks or through the valleys of mountain ranges tend to increase speed, which results in a local decrease in pressure (Bernoulli's Principle). A pressure altimeter within such an airflow would be subject to an increased error in altitude indication by reason of this decrease in pressure. This error will be present until the airflow returns to "normal" speed some distance downwind of the mountain or mountain range. Winds blowing over a mountain range at speeds in excess of about 50 knots and in a direction perpendicular (within 30 degrees) to the main axis of the mountain range often create the phenomena known as "Mountain or Standing Wave".
- b/ *Downdraft and Turbulence*: Downdrafts are most severe near a mountain and at about the same height as the summit. These downdrafts may reach an intensity of 83 feet/second (5,000 feet/minute) to the lee of high mountain ranges such as the Rockies. Although Mountain Waves often generate severe turbulence at times, flight through waves may be remarkably "smooth" even when the intensity of downdrafts and updrafts is considerable. As these smooth conditions may occur at night, or when an overcast exists, or when no distinctive cloud has formed, the danger to aircraft is enhanced by the lack of warning of the unusual flight conditions. Consider the circumstances of an aircraft flying parallel to a mountain ridge on the downwind side and entering a smooth, intense downdraft — although the aircraft starts descending because of the downdraft due to the local drop in pressure associated with the wave,

both the rate of climb indicator and the altimeter will initially not indicate a descent; in fact, both instruments may actually indicate a “climb” for part of this descent.

- c/ *Pressure Drop:* The “drop” in pressure associated with the increase in wind speeds extends throughout the Mountain Wave, that is, downwind and to “heights” well above the mountains. Isolating the altimeter error due solely to the Mountain Wave, or from error due to non-standard temperatures, would be of little value to a pilot. Of main importance is that Mountain Waves and non-standard temperature, in combination, may result in **AN ALTIMETER OVER READING BY AS MUCH AS 3,000 FEET.**

COMPUTER INDICATOR

Operation of the computer-indicator (Fig. 2-16) is automatic with the application of AC power. A failure warning flag with the word OFF, located in the face of the instrument, gives an OFF indication to the pilot in case of a power interruption or a component fault. If the OFF indication is caused by power failure, the flag will disappear when the power is restored. If the OFF indication is the result of a component failure, the flag will remain unchanged.

SERVO/PNEUMATIC ALTIMETER

Operation of the servo-pneumatic system is determined by the pilot’s mode selection. The instrument is energized for operation in the primary servo mode at take-off or in flight by moving the RESET/STBY switch to the RESET position. In the event that the instrument has changed to the standby mode of operation as a result of a fault in the system, the pilot may reset the altimeter to the servo mode by selecting the RESET position. Under “no go” conditions, the system will immediately refer to the standby mode when the reset switch is released. Any of the following conditions will cause the failure-monitor circuit to de-energize the relay, and the STBY warning flag to appear:

- a/ primary power failure;
- b/ servo amplifier or motor failure;
- c/ switch failure;
- d/ relay failure; and
- e/ gear train failure.

Before flight, the following *checks* should be performed (or as indicated in the AFM):

- a/ set current barometric pressure, using barosetting knob;
- b/ computer-indicator — plus or minus 50 feet of known elevation;
- c/ servo/pneumatic RESET mode — plus or minus 50 feet of known elevation and plus or minus 40 feet of computer-indicator display; and
- d/ servo/pneumatic STBY mode — plus or minus 50 feet of known elevation.



FIG. 2-16 • COMPUTER INDICATOR ALTIMETER

- 3. *RADAR ALTIMETER:* A radar altimeter (sometimes called a *radio altimeter*) indicates absolute altitude above the surface of the earth. A typical radar altimeter (Fig. 2-17) generally has a single pointer sweeping a logarithmic scale which expands toward 0. It usually features a minimum altitude marker which can be set to a desired altitude above ground and which generates a visual and/or audio warning when the aircraft descends to, or is below, the preset value. The radar altimeter may also feature a warning flag which is actuated whenever large pitch or bank angles introduce a slant range inaccuracy.



FIG. 2-17 • RADAR ALTIMETER INDICATOR

The equipment determines height by measuring the time delay between the transmission of downward-directed radio waves and the reception of ground-reflected signals. Inaccuracies may be present during flight over any medium into which radio waves can penetrate (ice, deep snow), or over rapidly changing terrain.

- 4. *ALTITUDE ALERTING SYSTEM:* An altitude alerting system works with altimeter data. The desired level-off altitude is set on the altitude selector during a climb or descent.

The pilot is alerted by aural or visual signals upon approaching the prescribed altitude in sufficient time to establish level flight at that preselected altitude (usually 1,000 ft. above or below the selected altitude). A typical altitude alerting system is shown in Fig. 2-18.

5. **VERTICAL SPEED INDICATOR:** The Vertical Speed Indicator (VSI) displays the vertical component of an aircraft's flight path. It measures the rate of change of static pressure in terms of feet per minute of climb or descent. The VSI automatically compensates for changes in atmospheric density.

The VSI is in a sealed case connected to the static line through a calibrated leak (restricted diffuser). Inside the case, a diaphragm attached to the pointer by a system of linkages is vented to the static line without restrictions.

As the aircraft climbs, the diaphragm contracts and the pressure drops faster than the case pressure can escape through the restrictor, resulting in climb indications; the reverse is true during descent. If level flight is resumed, pressure equalizes in the case and diaphragm within six to nine seconds and the pointer returns to zero rate of climb. The vertical speed indicator has 100-ft calibrations with numbers every 500 ft (Fig. 2-19).

The vertical speed indicator has two separate functions. First, it operates as a *trend instrument* because it shows deviations from level flight before the altimeter registers any signs. There is no lag in this function. Second, it serves as a *rate indicator*. The calibrated leak prevents the pressure differential between the case and the bellows from equalizing immediately, causing an inherent lag. When the aircraft starts a climb or descent, it takes a few seconds for a pressure differential to develop between the same areas and indicate a rate of movement. The same is true when levelling off.

In summary, when the aircraft begins a climb or descent, the instrument immediately displays the change in pitch;

however, the pilot must wait for six to nine seconds for an accurate indication of the rate of climb or descent. Nonetheless, the vertical speed indicator is valuable in sensing deviations from a selected altitude or establishing a constant rate of climb or descent.

6. **INSTANTANEOUS VERTICAL SPEED INDICATOR:** An instantaneous vertical speed indicator (IVSI) displays vertical speed information with essentially zero time lag. A single pointer indicates rate of altitude change against a fixed circular scale much the same as a vertical speed indicator. (Fig. 2-20).

This instrument is similar in operation to a vertical speed indicator, except that *accelerometers* have been added to the linkage between the capsule and the pointers. These sense accelerations of vertical velocity and provide appropriate motion to the pointer before any static pressure differential has been established.

G. AIR DATA SYSTEM

1. **GENERAL:** An air data system utilises the pitot-static system and is found on more sophisticated aircraft. It measures, processes, and converts aerodynamic and thermodynamic sensations into electrical signals, synchro outputs, or digital codes.

This system may be used to activate differential pressure flight instruments and to provide information to numerous other aircraft systems. It may incorporate features such as:



FIG. 2-18 • ALTITUDE ALERTING SYSTEM



FIG. 2-19 • FACE OF VERTICAL SPEED INDICATOR



FIG. 2-20 • INSTANTANEOUS VERTICAL SPEED INDICATOR

- a/ separate systems to drive the pilot and co-pilot displays, with comparison monitoring between both systems;
 - b/ self-test circuits; and
 - c/ internal failure-monitoring circuits.
2. *COMPONENTS:* A basic air data system consists of the following components:
- a/ *Sensors.* Sensors measure ambient atmosphere surrounding the aircraft. All systems use a pitot tube, static ports, and a temperature probe. More complex systems will also make use of an angle of attack sensor;
 - b/ *Transducers.* Transducers convert the sensed pressure, temperature, and angles to voltages, synchro outputs, or digital pulses. The accuracy and performance of the transducers govern the over-all efficiency of the entire system;
 - c/ *Computer.* A computer can be designed to perform a multitude of functions, such as:
 - 1/ calculating TAS, mach number, corrected static pressure, and corrected outside air temperature,
 - 2/ originating correction signals to transducers,
 - 3/ driving displays,
 - 4/ supplying signals to navigation computers,
 - 5/ controlling aircraft pressurization, and
 - 6/ providing inputs to automatic flight control systems and engine fuel control units.
3. *AIR DATA OUTPUTS:* A complex air data system can supply a great number of outputs, many of which may be electronic or mechanical variations on the method of presenting one basic parameter of flight (eg. static pressure).

Some of the common outputs are:

- a/ *Pressure Altitude.* Sensed static pressure is corrected to pressure altitude based on the ICAO Standard Atmosphere;
 - b/ *Airspeed.* May be presented as indicated airspeed or converted into the true airspeed for use in DR navigation or in Doppler and inertial navigation systems;
 - c/ *Air Density.* Computed according to elementary gas laws and used for engine controls;
 - d/ *Mach-Number.* Calculated from pitot and static pressures;
 - e/ *Air Temperature.* Corrected for frictional heating and air compression at the temperature probe;
 - f/ *Angle of Attack.* True angle of attack is attained by correcting measured angle of attack for airspeed; and
 - g/ *Rate of Change of Altitude and Speed.* May be calculated in the computer.
4. *INHERENT SYSTEM ERRORS:* Central air data computers (CADC) are subject to the following errors:
- a/ *Position Error.* This error varies with aircraft type and external configuration. Flight tests are conducted to plot this error on an airspeed, altitude, and configuration curve. The computer manufacturer designs a corrective mechanism or electrical circuit to correct the static-pressure electrical signal being supplied to all instruments. This results in calibrated airspeed, actual TAS, calibrated altitude, and true Mach indications on the instruments. Because of the individual aircraft type position error, the CADC has to be 'tailored' to that particular aircraft type and is not suitable for use in other types; and
 - b/ *Scale Error.* Also referred to as instrument error, scale error is associated with a particular set of

altitude aneroids and varies with altitude. The individual aneroids of a particular CADC can be plotted for scale error. A corrective camshaft designed to correct the altitude output signal is installed to minimize errors.

NOTE:

Failure of certain components in instruments receiving inputs from a CADC can result in the display of invalid information without an accompanying warning flag or light.

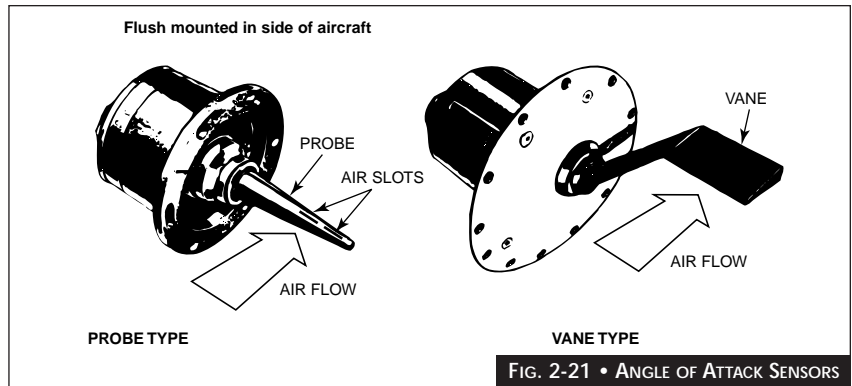

H. ANGLE-OF-ATTACK SYSTEM

1. *GENERAL:* The angle of attack is the angle measured between the relative airflow and the wing chord line of an aircraft.

An angle-of-attack system may be used to:

- a/ depict critical angles of attack during an approach and landing;
- b/ provide stall warning;
- c/ assist in establishing optimum aircraft attitude for specific conditions of flight, such as maximum range or endurance; and
- d/ verify airspeed indications or computations.

2. *SYSTEM COMPONENTS:* An angle of attack system consists of the following components:

- a/ *Sensors.* One or more sensors protrude into the relative airflow. There are two common types (Fig. 2-21):
 - 1/ the vane acts like an aerofoil and aligns itself with the relative airflow;
 - 2/ the probe detects the relative airflow by sensing differential pressure through ports or slots.
- b/ *Transducer.* Both types of sensors, when aligning with the relative airflow, generate a signal which is passed to the cockpit indicator either directly or through an air data system;

c/ *Indicators.* Various display methods and cockpit indicators are in use. Fig. 2-22 gives one example. Information may be presented in the form of actual angles, units or symbols; and

d/ *Stall-Warning Devices.* Most systems incorporate additional devices, such as electrically operated 'stick shakers' and/or horns to warn of impending stalls and stick pushers which activate if stall recovery action is not initiated.



WARNING:

Displays relating to approach and landing may be based on the assumption that the aircraft is always in the normal landing configuration. For any system which does not automatically compensate for variations in configurations, the pilot must determine and apply the necessary corrections.

2.1.3

GYROSCOPIC SYSTEMS AND INSTRUMENTS

A. GENERAL

The gyro instruments include the heading indicator, attitude indicator and turn coordinator (or turn-and-slip indicator). Each contains a gyro rotor driven by air or electricity and each makes use of the gyroscopic principles to display the attitude of the aircraft. It is important that instrument pilots understand the

gyro instruments and the principles governing their operation.

B. PRINCIPLES

1. **RIGIDITY IN SPACE:** The primary trait of a rotating gyro rotor is rigidity in space, or gyroscopic inertia. Newton's First Law states in part: "A body in motion tends to move in a constant speed and direction unless disturbed by some external force". The spinning rotor inside a gyro instrument maintains a constant attitude in space as long as no outside forces change its motion. This stability increases if the rotor has great mass and speed. Thus, the gyros in aircraft instruments are constructed of heavy materials and designed to spin rapidly (approximately 15,000 rpm for the attitude indicator and 10,000 rpm for the heading indicator).

The heading indicator and attitude indicator use gyros as an unchanging reference in space. Once the gyros are spinning, they stay in constant positions with respect to the horizon or direction. The aircraft heading and attitude can then be compared to these stable references. For example, the rotor of the *universally mounted gyro* (Fig. 2-23) remains in the same position even if the surrounding gimbals, or circular frames, are moved. If the rotor axis represents the natural horizon or a direction such as magnetic north, it provides a stable reference for instrument flying.

2. **PRECESSION:** Another characteristic of gyros is precession, which is the tilting or turning of the gyro axis as a result of applied forces. When a deflective force is applied to the rim of a stationary gyro rotor, the rotor moves in the direction of the force. When the rotor is spinning, however, the same forces causes the rotor to move in a different direction, as though the force had been applied to a point 90° around the rim in the direction of rotation. (Fig. 2-24). This turning movement, or precession, places the rotor in a new plane of rotation, parallel to the applied force.

Unavoidable precession is caused by aircraft manoeuvring and by the internal friction of attitude and directional gyros. This causes

slow "drifting" and thus erroneous readings.

When deflective forces are too strong or are applied very rapidly, most older gyro rotors topple over, rather than merely precess. This is called "tumbling" or "spilling" the gyro and should be avoided because it damages bearings and renders the instrument useless until the gyro is erected again. Some of the older gyros have caging devices to hold the gimbals in place. Even though caging causes greater than normal wear, older gyros should be caged during aerobatic manoeuvres to avoid damage to the instrument. The gyro may be erected or reset by a caging knob.

Many gyro instruments manufactured today have higher attitude limitations than the older types. These instruments do not "tumble" when the gyro limits are exceeded, but, however, do not reflect pitch attitude beyond 85° nose up or nose down from level flight. Beyond these limits the newer gyros give incorrect readings. These gyros have a self-erecting mechanism that eliminates the need for caging. The tumble limits of older gyros and the attitude limitations of the newer gyros follow.

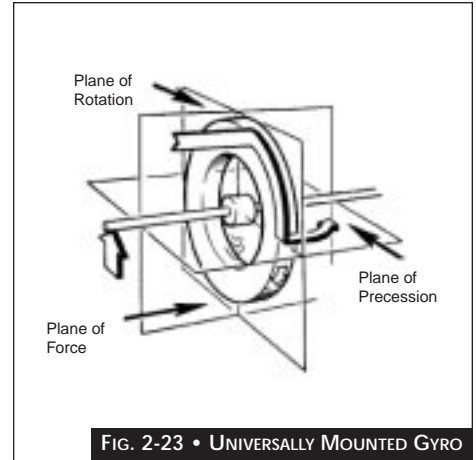

FIG. 2-23 • UNIVERSALLY MOUNTED GYRO

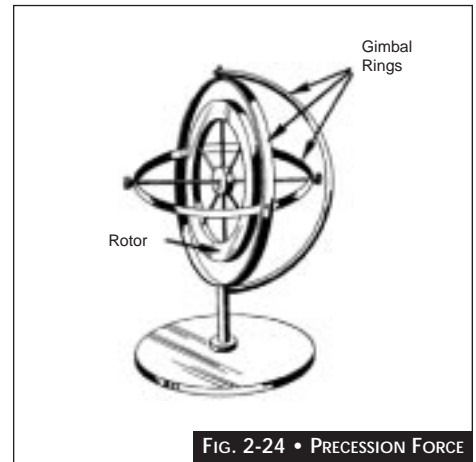

FIG. 2-24 • PRECESSION FORCE

INSTRUMENT	NEW TYPE	OLD TYPE
ATTITUDE INDICATORS	360° of bank	100° of bank
	85° of pitch	70° of pitch
HEADING INDICATORS	85° of bank	55° of bank
	85° of pitch	55° of pitch

C. GYRO POWER SOURCES:

Air or electricity supply the power to operate gyro instruments in light aircraft. If the directional indicator and attitude indicator are air-driven (as they generally are), the turn-and-slip indicator is electrically powered. The advantage of this arrangement is that if the vacuum system (which supplies air) fails, the instrument pilot still has the compass and the turn indicator for attitude and direction reference, in addition to the pitot-static instruments.

1. **VACUUM POWER SYSTEM:** Air-driven gyros normally are powered by a vacuum pump attached to and driven by the engine. Suction lines connect the pump to the instruments, drawing cabin air through the filtered openings in the instrument case. As the air enters the case, it is accelerated and directed against small “buckets” cast into the gyro wheel. A regulator is attached between the pump and the gyro instrument case to control suction pressure. There is normally a vacuum gauge, suction gauge (Fig. 2-25) or warning light. Because a constant gyro speed is essential for reliable instrument readings, the correct suction pressure is maintained with a vacuum pressure regulator.

The air is drawn through a filter, to the instruments and then to the pump where it is vented to atmosphere. The pilot should consult the aircraft operating manual for specific information with regard to vacuum system normal operating values. Low gyro rotation speeds cause slow instrument response or lagging indications, while fast gyro speeds cause the instruments to overreact in addition to wearing the gyro bearings faster and decreasing gyro life.

2. **ELECTRICAL POWER SYSTEM:** An electric gyro, normally used to drive the turn coordinator or turn-and-slip indicator, operates like a small electric motor with the spinning gyro acting as the motor armature. Gyro speed in these instruments is approximately 8,000 rpm.

Aircraft that normally operate at high altitudes do not use a vacuum system to power flight instruments because pump efficiency is limited in the thin, cold air.

Instead, alternating current (a.c.) drives the gyros in the heading and attitude indicators. The a.c. power is provided by inverters that convert direct current to alternating current. In some cases, the a.c. power is supplied directly from the engine-driven alternator or generator.

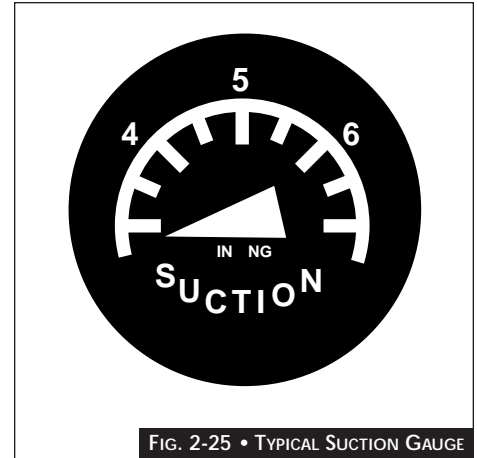

FIG. 2-25 • TYPICAL SUCTION GAUGE

D. GYROSCOPIC INSTRUMENTS

1. **ATTITUDE INDICATOR**
BASIC COMPONENTS AND OPERATION

The purpose of the attitude indicator is to present the pilot with a continuous picture of the aircraft's attitude in relation to the surface of the earth. Fig. 2-26 shows the face of a typical attitude indicator. It should be noted that other attitude indicators differ in details of presentation.



FIG. 2-26 • ATTITUDE INDICATOR

Pitch attitudes are depicted by the miniature aircraft's relative movement up or down in relation to the horizon bar, also called the gyro or attitude horizon. Usually at least four pitch reference lines are incorporated into the instrument. Two are below the artificial horizon bar and two are above.

The bank indicator, normally located at the top of the instrument, shows the degree of bank during turns through the use of index marks. These are spaced at 10° intervals through 30°, with larger marks placed at 30°, 60° and 90° bank positions.

The nose of the aircraft is depicted by a small white dot located between the fixed set of wings or by the point of the triangle as in Fig. 2-26. The sky is represented by a light blue and the earth is shown by black or brown shading. Converging lines give the instrument a three-dimensional effect.

The small knob near the bottom of the instrument is used for vertical adjustment of the miniature aircraft. During straight-and-level flight the miniature aircraft should be adjusted so that it is superimposed on the horizon bar.

Once the artificial horizon line is aligned with the natural horizon of the earth during initial erection, the artificial horizon is kept horizontal by the gyro on which it is mounted. An erection mechanism automatically rights the gyro when precession occurs due to manoeuvres or friction. When the older-type gyro tumbles as a result of extreme attitude changes, the rotor normally precesses slowly back to the horizontal plane.

Even an attitude indicator in perfect condition can give slight erroneous readings. Small errors due to acceleration and deceleration are not significant because the erection device corrects them promptly; nonetheless, the pilot should be aware of them (refer to the paragraphs below). Large errors may be caused by wear, dirty gimbal rings, or out-of-balance parts. Warning flags (see Fig. 2-26) may mean either that the instrument is not receiving adequate electrical power or that there is a problem with the gyro. Refer to the AFM for specific details.

Principal Attitude Indicator Errors

TURN ERROR

During a normal co-ordinated turn, centrifugal force causes the gyro to precess toward the inside of the turn. This precession increases as the bank steepens; therefore, it is greatest during the actual turn. The error disappears as the aircraft rolls out at the end of a 180° turn at a normal rollout rate.

Therefore, when performing a steep turn, the pilot may use the attitude indicator for rolling in and out of the turn, but should use other instruments (VSI and altimeter) during the turn for specific pitch information.

ACCELERATION ERROR

As the aircraft accelerates (e.g., during

takeoff), there is another type of gyro precession which causes the horizon bar to move down, indicating a slight pitch up attitude. Therefore, takeoffs in low visibility require the use of other instruments such as the altimeter to confirm that a positive rate of climb is established immediately after takeoff.

DECELERATION ERROR

Deceleration causes the horizon bar to move up, indicating a false pitch down attitude.

ADDITIONAL ASPECTS

Because the attitude indicator is the most important instrument during IFR flight, the pilot should be aware of some additional uses and characteristics:

- a/ if the attitude indicator has not tumbled, it can assist the pilot greatly in recovering from unusual attitudes;
- b/ the attitude indicator displays the degree of bank used during a turn, but it cannot provide information about the quality (co-ordination) of the turn. Co-ordination can be determined only by using the ball in the turn indicator; and
- c/ the rate of turn is not shown by the attitude indicator but rather the turn indicator. When performing standard rate turns, the pilot should establish the initial angle of bank by using the attitude indicator, then check the turn indicator to ascertain if the bank angle is correct. After making any necessary corrections, the pilot maintains the resulting bank on the attitude indicator.

2. **HEADING INDICATOR:** The heading indicator, (Fig. 2-27) formerly called the *directional gyro*, uses the principle of gyroscopic rigidity to provide a stable heading reference. The pilot should remember that real precession, caused by manoeuvres and internal instrument errors, as well as apparent



FIG. 2-27 • HEADING INDICATOR

precession caused by aircraft movement and earth rotation, may cause the heading indicator to "drift".

In newer heading indicators, the vertical card or dial on the instrument face appears to revolve as the aircraft turns. The heading is displayed at the top of the dial by the nose of the miniature aircraft (Fig. 2-27). Another type of direction indicator shows the heading on a ring similar to the card in a magnetic compass.

Because the heading indicator has no direction-seeking qualities of its own, it must be set to agree with the magnetic compass. This should be done only on the ground or in straight-and-level, unaccelerated flight when magnetic compass indications are steady and reliable.

The pilot should set the heading indicator by turning the heading indicator reset knob at the bottom of the instrument to set the compass card to the correct magnetic heading. On large aircraft, this function is done using a *compass controller* (Fig. 2-28).

The pilot of a light aircraft should check the heading indicator against the magnetic compass at least every 15 minutes to assure accuracy. Because the magnetic compass is subject to certain errors (refer to article 2.1.4E), the pilot should ensure that these errors are not transferred to the heading indicator.

3. **RATE AND QUALITY OF TURN INDICATORS:** There are two types of rate and quality of turn indicators, the turn co-ordinator and the turn-and-slip indicator (Figs. 2-29 and 2-30).

Both of these gyroscopic instruments indicate the rate at which the aircraft is turning. The *turn co-ordinator* contains a miniature schematic aircraft to shown when the actual aircraft is turning. The *turn-and-slip indicator*, on the other hand, has a vertical needle which deflects in the direction the aircraft is turning.

TURN-AND-SLIP INDICATOR

The turn-and-slip indicator (Fig. 2-29) provides the only information of either

wing's level or bank attitude if the other gyroscopic instruments should fail. This indicator is sometimes called the "needle and ball". This instrument, along with the airspeed indicator, magnetic compass and altimeter, can assist the pilot in flying through instrument weather conditions, even when it is the only gyro instrument operating.



FIG. 2-28 • COMPASS CONTROLLER

The turn needle of the turn-and-bank indicator gives an indirect indication of the bank attitude of the aircraft. When the turn needle is exactly centred, the aircraft is in straight flight. When the needle is displaced from centre, the aircraft is turning in the direction of the displacement. Thus, if the ball is centred, a left displacement of the turn needle means the left wing is low and the aircraft is in a left turn. Return to straight flight is accomplished by co-ordinating aileron and rudder pressures.



FIG. 2-29 • TURN AND SLIP INDICATOR

The ball of the turn-and-bank indicator is actually a separate instrument, conveniently located under the turn needle so the two instruments can be used together. This instrument is best used as an indication of attitude. When the ball is centred within its glass tube the manoeuvre is being executed in a co-ordinated manner. However, if the ball is out of its centre location, the aircraft is either slipping or skidding. The side to which the ball has rolled indicates the direction of the slip or skid.

In a *slip*, the rate of turn is too slow for the angle of bank, and the lack of centrifugal force causes the ball to be displaced to the inside of the turn. (To correct, decrease the angle of bank, or use rudder to increase the rate of turn, or both). In a *skid*, the rate of

turn is too fast for the angle of bank, and excessive centrifugal force causes the ball to be displaced to the outside of the turn. (To correct, increase the bank angle, or use rudder to decrease the rate of turn, or both).

In co-ordinated flight, the needle may be used to measure the rate of turn; in a "standard rate turn", the needle is aligned with the left or right marker (dog-house) and the aircraft will turn at the rate of 3°/sec or 180° in one minute. Hence, in these conditions, the needle indicates both direction and rate of turn.

The answer to controlling and trimming an aircraft in straight and level flight by means of the turn-and-bank indicator requires a return to basic control principles - i.e., control yaw with the rudder and keep the wings level with aileron. Therefore, when flying straight and level through the use of the turn-and-bank indicator, prevent yawing with appropriate rudder pressure, and keep the wings level with appropriate aileron pressure. The needle will not deflect while heading is constantly maintained, since no turn exists.

In other words, control the ball with rudder since the ball moves parallel to a plane passing through the rudder pedals, and control the needle with aileron since the ailerons affect bank angle, a primary requirement for a normal turn.

It is important that both the needle and ball are used together. The problem associated with using these instruments separately is that although the ball will positively indicate that the aircraft is slipping or skidding, just which one of these the aircraft is doing can only be determined by reference to the needle. Furthermore, the needle will not positively indicate a bank attitude. An aircraft could be in a bank attitude and yet the needle could remain centred or indicate a turn in the opposite direction, if controls are not co-ordinated.

TURN CO-ORDINATOR

Most current aircraft have a turn co-ordinator that replaces the older turn-and-slip instrument. A small aircraft silhouette rotates to show how the aircraft is turning

(Fig. 2-30). When the aircraft turns left or right, the aircraft silhouette banks in the direction of the turn. When the wing of the aircraft silhouette is aligned with one of the lower index marks, the aircraft is in a standard-rate turn (3°/sec.).

This instrument also senses the roll rate because the gyro is tilted on its fore and aft axis. The electric gyro is canted approximately 35°; therefore, the miniature aircraft banks whenever the actual aircraft rotates about either the yaw or roll axis. This freedom of movement enables the gyro to indicate immediately when the aircraft is turning. After the bank angle for a turn is established and the roll rate is zero, the aircraft symbol indicates only the rate of turn.

The miniature aircraft moves independently of the ball or inclinometer. The position of the ball indicates the quality of the turn. When the miniature aircraft depicts a turn and the ball is not centred, it shows that the turn is not co-ordinated (Fig. 2-31).



FIG. 2-30 • TURN CO-ORDINATOR

If the miniature aircraft is level and the ball is displaced to either side (Fig. 2-31), the aircraft is flying straight but with one wing low.

The pilot should understand the relationship of true airspeed and angle of bank as it affects the rate and radius of turn. Fig. 2-32 shows three aircraft flying with the same angle of bank but at different airspeeds. The aircraft with the greatest rate

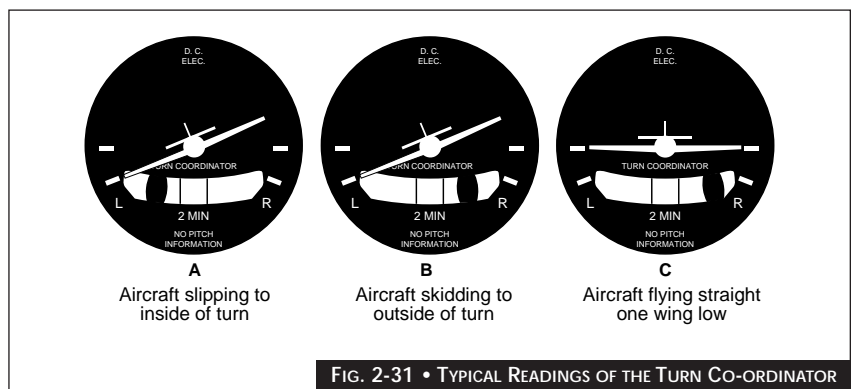

FIG. 2-31 • TYPICAL READINGS OF THE TURN CO-ORDINATOR

of turn is aircraft A. If two aircraft are turning at the same angle of bank, the slower aircraft has the shorter turning radius and also a greater rate of turn.

A common misconception is that faster aircraft will complete a 360° turn in the least time. For example, a jet in a 20° bank flying at a true airspeed of 350 kts requires approximately 5.3 minutes to complete a 360° turn. Aircraft A, with also a 20° bank but a true airspeed of 130 kts, requires just two minutes to complete a 360° turn.

The radius of turn also increases with an increase in airspeed, varying with the square of the true airspeed. Therefore, because the speed of aircraft C is about three times that of aircraft A, the turning radius of aircraft C is approximately nine times that of aircraft A.

4. *THE GYROSYN COMPASS SYSTEM:* A gyrosyn compass system has a remotely located unit for sensing the earth's magnetic field. It incorporates a gyroscope to provide stability. Electrical power is required for its operation.

A variety of cockpit indicators may be driven by a gyrosyn compass system, including fixed-card instruments, or moving-card indicators such as a radio-magnetic indicator (RMI) or a horizontal situation indicator (HSI).

All gyrosyn compass systems have a set of basic components whose operation is similar, regardless of the aircraft type:

- a/ *REMOTE COMPASS TRANSMITTER:* The remote compass transmitter senses the earth's magnetic field. It is usually remotely located to reduce aircraft magnetic disturbances. The sensing element is pendulously suspended within a sealed bowl (fluid-filled to prevent excessive swinging) and maintains a horizontal plane within a pitch attitude of +30 degrees. During large changes in heading, airspeed or pitch the sensing element is displaced from the horizontal plan and produces erroneous signals. These generally have little effect because of the stability

provided by the gyro, and a return to straight-and-level, unaccelerated flight again provides correct orientation signals;

- b/ *GYROSCOPE:* The gyroscope principle of rigidity in space is applied to retain a fixed position during any aircraft turns. Turning motion of the aircraft about the gyro is then electrically relayed to the heading indicator;
- c/ *ERECTION MECHANISM:* An erection torque motor is used to keep the gyro spin axis in a horizontal plane;
- d/ *AMPLIFIER:* The amplifier is the coordination and distribution centre for all system electrical signals. Remote compass transmitter signals are phase-detected to resolve for the 180—degree ambiguity and are sent to the slaving torque motor to keep the gyro spins axis aligned with magnetic north-south. The amplifier also provides high voltage to the slaving torque motor for any periods of fast slaving; and
- e/ *HEADING INDICATOR UNIT:* See Fig. 2-27.

NOTE:

Some gyrosyn compass systems are capable of non-slaved operation in extreme northern or southern latitudes where the earth's magnetic field is distorted or weak. In this situation:

- a. *the remote compass transmitter does not function;*
- b. *the gyro must be oriented manually for heading and then serves as the only directional reference;*

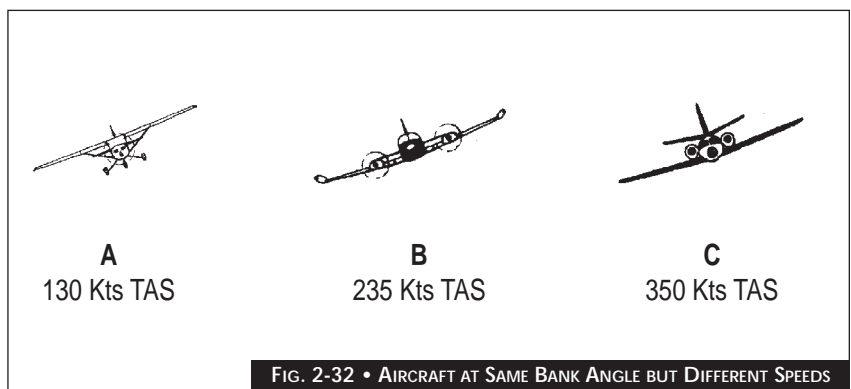

FIG. 2-32 • AIRCRAFT AT SAME BANK ANGLE BUT DIFFERENT SPEEDS

- c. aircraft turning motion about the gyro is still relayed electrically to the heading indicator; and
- d. some form of latitude correction is necessary to overcome the effects of apparent precession.

2.1.4
MAGNETIC COMPASS

A. GENERAL

The magnetic compass was one of the first flight instruments. Even today, it is frequently the only direction-indicating instrument found in aircraft equipped only for VFR flight. The compass is a reliable, self-contained unit requiring no external power source. For this reason, it is extremely useful as a *standby* or *emergency* instrument. To use a magnetic compass satisfactorily, however, the pilot must understand certain principles of magnetism and the characteristics of a magnetic compass.

B. PRINCIPLES

A magnet attracts ferrous (iron) materials by producing an external magnetic field. The force of attraction is greatest at the poles of the magnet and least in the area halfway between the two poles. Lines of force flow from each of these poles, then bend around and flow toward the opposite pole, thus forming a magnetic field.

The earth is a huge magnet, with lines of force oriented approximately with the north and south magnetic poles. Because the aircraft compass is suspended to swing freely, it tends to align with the earth's magnetic lines of force.

The earth's magnetic poles are some distance from the geographic or "true" poles. The magnetic lines of force do not pass over the surface in a neat geometric pattern because they are influenced by the varying mineral content of the earth's crust. For these reasons, there is usually an angular difference, or *variation*, between true north and magnetic north from a given geographic location.

Although this variation is not equal at all points on the earth, it does follow a pattern. Points of equal variation can be connected by an *isogonic*

line which can be plotted accurately on a chart (Fig. 2-34). In some places this variation is easterly; other places it is westerly. This variation is shown on sectional and IFR charts (Fig. 2-35) using long dashed lines.

The pilot must understand the difference between *true north* and *magnetic north* (called variation) because some of the directional values used in aviation are stated in terms of magnetic north while others are stated in terms of true north. For example, the direction finding instruments in the aircraft, including the magnetic compass, present heading information in terms of magnetic north. All tracks, headings, and runways are stated in terms of magnetic north. Maps, however, are constructed on true north. In addition, wind direction is usually given in terms of true north, except surface wind direction given by a control tower, which is stated in relationship to magnetic north.

The pilot must use the variation to convert a direction expressed in terms of true north to magnetic north. To calculate magnetic azimuth, the pilot must *subtract easterly variation or add westerly variation* from the true azimuth (Fig. 2-36). If the pilot wishes to convert a magnetic heading to a true heading, he or she must perform the opposite calculations.

C. MAGNETIC DIP

The lines of force in the earth's magnetic field pass through the centre of the earth, exit at both magnetic poles, and bend around to re-enter at the opposite pole (Fig. 2-37). Near the Equator, these lines become almost parallel to the surface of the earth. However,



FIG. 2-33 • MAGNETIC COMPASS

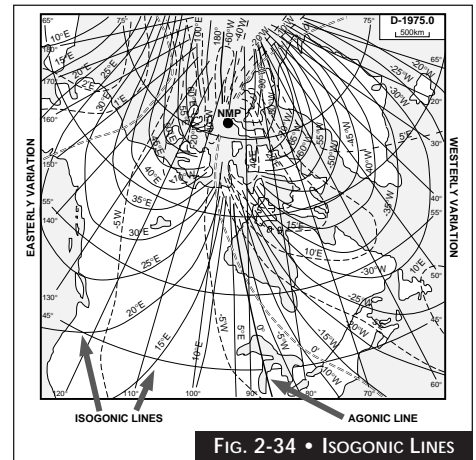

FIG. 2-34 • ISOGONIC LINES



FIG. 2-35A • IFR CHART SHOWING MAGNETIC VARIATION

as they near the poles, they tilt toward the earth until in the immediate area of the magnetic poles they dip rather sharply into the earth. Because the poles of a compass tend to align themselves with the magnet lines of force, the magnet within the compass tends to tilt or dip toward the earth in the same manner as the lines of force.

D. COMPASS CONSTRUCTION

The aircraft's magnetic compass is a simple, self-contained instrument (Fig. 2-33). It consists of a sealed outer case within which is located a pivot assembly and a float containing two or more magnets. A *compass card* is attached to the float with the cardinal headings (north, east, south and west) shown by corresponding letters. Between the cardinal headings, each 30° increment is shown as a number with the last zero removed. For example, 30° is shown as a numeral 3. The pilot may think of the compass card as a soup bowl turned upside down and balanced precisely on the point of a pencil. It rotates freely and can tilt up to 18°.

The case is filled with an acid-free white kerosene that helps to dampen oscillations of the float and lubricate the pivot assembly. The pivot assembly is spring-mounted to further dampen aircraft vibrations so that the compass heading may be read more easily. A glass face is mounted on one side of the compass case with a lubber, or reference, line in the centre. Compensating magnets are located within the case to correct the compass reading for the effects of small magnetic fields generated by components of the aircraft (refer to the next subsection).

E. COMPASS ERRORS

1. **DEVIATION:** The compass needle is affected when aircraft electrical equipment is operated and by the ferrous metallic components within the aircraft. These internal magnetic fields tend to deflect the compass from alignment with magnetic north. This tendency is called deviation. Deviation varies, depending upon which electrical components are in use.

The local magnetic field may also change as a result of mechanical jolts to the aircraft,

from the installation of additional or different radio equipment, or major mechanical work on an engine such as changing of the crankshaft or propeller. The crankshaft and the propeller are particularly susceptible to changes in inherent magnetism because they rotate in various magnetic fields.

To reduce the effect of this deviation, the aircraft compass must be checked and compensated periodically by adjusting the compensating magnets. This procedure is called "*swinging the compass*". During compensation, the compass is checked at 30° increments. Adjustments are made at each of these points, and the difference between magnetic heading and compass heading is shown on a *compass correction card* (Fig. 2-38). When flying compass headings, the pilot must refer to this card and make the appropriate adjustment for the desired heading. To preserve accuracy, the pilot must ensure that no metallic objects such as flashlights or sunglasses are placed near the compass because they may induce significant errors.

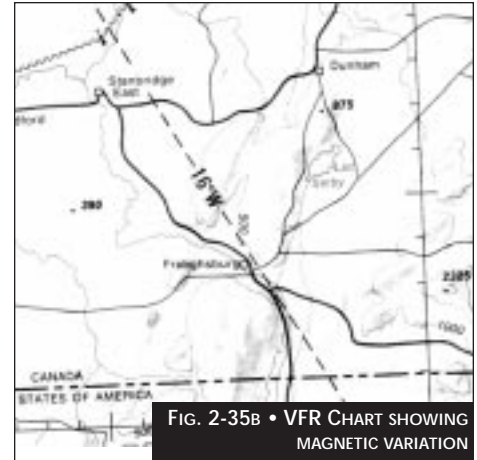

FIG. 2-35B • VFR CHART SHOWING MAGNETIC VARIATION

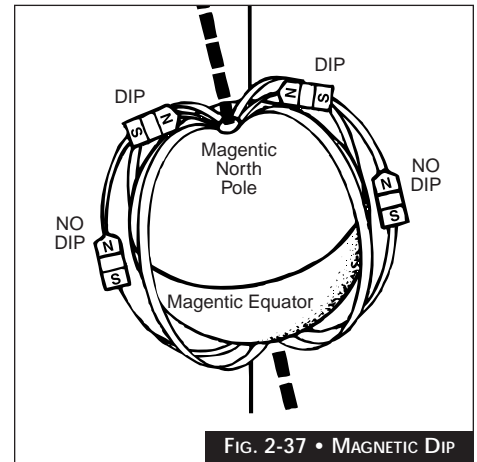

FIG. 2-37 • MAGNETIC DIP

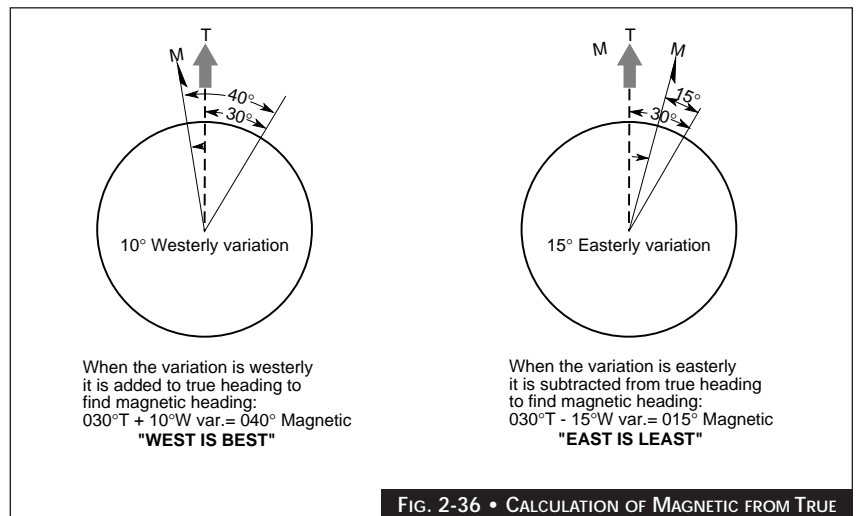

FIG. 2-36 • CALCULATION OF MAGNETIC FROM TRUE

2. **DIP ERROR:** As previously mentioned, the compass card tends to align itself with the earth's magnetic field. At or near the Equator this causes little or no problem, but as the aircraft nears either of the magnetic poles, the dip error becomes significant.

In this manual, only dip errors in the Northern Hemisphere are described. (The errors are reversed in the Southern Hemisphere). *Northerly turning error* is the most important error (Fig. 2-39).

The compass card is mounted so that its centre of gravity is well below the pivot point on the pedestal. When the aircraft is in a banked turn, the card also banks because of centrifugal force. While the card is in the banked attitude, the vertical component of the earth's magnetic field causes the compass to dip to the low side of the turn.

The error is most apparent when turning through headings close to north and south. When the aircraft makes a turn from a heading of north, the compass briefly indicates a turn in the opposite direction. When the aircraft makes a turn from a heading of south, the compass indicates a turn in the correct direction but at a considerably faster rate than is actually occurring. Thus, when making a 360° right turn beginning at north, the compass card initially turns in the wrong direction; then, as the aircraft passes through east, the compass "catches up" with the actual heading. Passing through south, the compass leads the turn considerably. As the aircraft nose passes through west, the compass should approximate the correct heading. Then, as the aircraft nose approaches north again, the compass lags.

Pilots must understand that the northerly turning error occurs only while the aircraft is turning.

Acceleration error occurs during airspeed changes and is most apparent on headings of east and west. It is caused by a combination of inertia and magnetic dip. As the aircraft accelerates, the compass card, acting like a pendulum, tilts slightly during the acceleration because of the card's inertia.

FOR	0°	30°	60°	90°	120°	150°	180°	210°	240°	270°	300°	330°
STEER	359°	30°	60°	88°	120°	152°	183°	212°	240°	268°	300°	329°

FIG. 2-38 • COMPASS CORRECTION CARD

This momentary tilting displaces the compass card from its normal alignment with magnetic north; therefore, when the aircraft accelerates in either an easterly or westerly direction, the compass card momentarily indicates a turn toward the north (Fig. 2-40). The reverse is true when the aircraft decelerates on a heading of approximately east or west, the

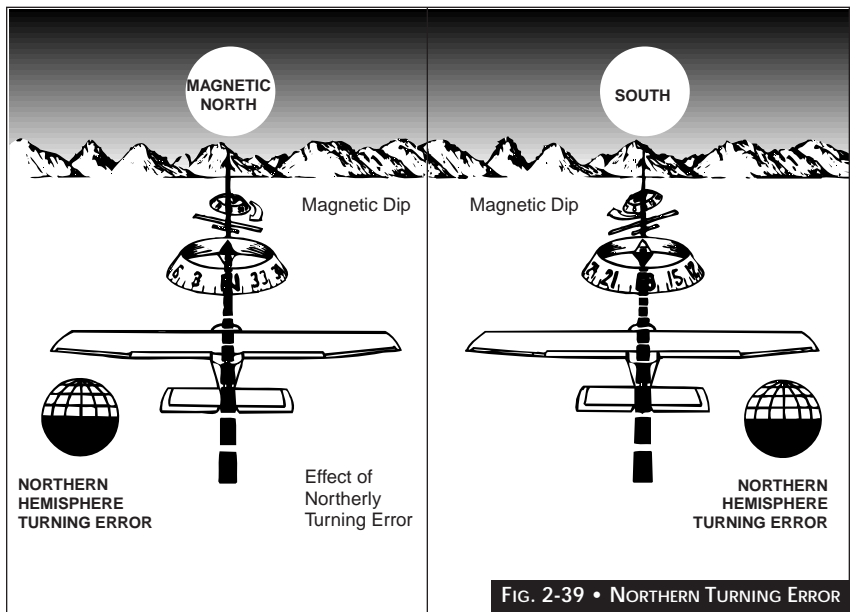

pendulum effect causes the compass card to rotate erroneously toward the south.

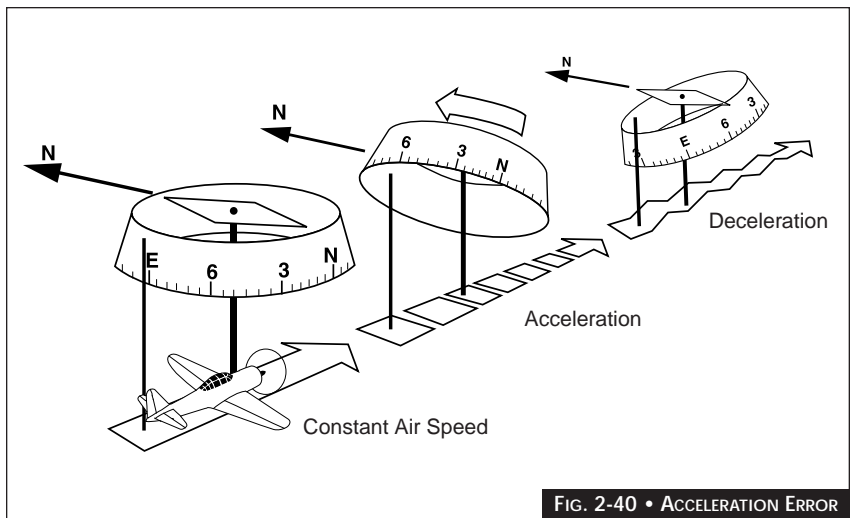

Pilots should remember the acronym *ANDS*: *accelerate north, decelerate south*.

F. USE OF THE MAGNETIC COMPASS

It now should be evident why the magnetic compass is accurate only while the aircraft is flying wings-level in steady-state, non-accelerated flight. Turns using the magnetic compass can be accomplished best with the aid of the turn co-ordinator and the clock.

In a two-minute or standard-rate turn, as shown on the turn co-ordinator, the aircraft turns through 360 degrees in two minutes, or 3°/sec. By dividing by three the number of degrees in the planned turn, the pilot may determine the number of seconds required in a standard-rate turn to accomplish the desired heading change. After rolling the aircraft out on the new heading, the pilot must wait a few seconds for the compass to settle down. Then he or she can check the new heading.

2.1.5 FLIGHT DIRECTOR SYSTEMS

A. GENERAL

A flight director system (FDS) combines many of the previously described instruments to provide an easily interpreted display of the aircraft's flight path. The pre-programmed path, automatically computed, furnishes the steering commands necessary to obtain and hold a desired path.

The major components of a flight director system are the flight director indicator (FDI), a horizontal situation indicator (HSI), a mode selector and a flight director computer. The following paragraphs describe a common type of FDS.

B. FLIGHT DIRECTOR INDICATOR

Elements of a flight director indicator (Fig. 2-41) are:

- 1/ attitude indicator;
- 2/ a fixed aircraft symbol;
- 3/ pitch and bank command bars;
- 4/ glide slope indicator;
- 5/ localizer deviation indicator;
- 6/ slip indicator;
- 7/ warning flag for gyro, computer and glide slope.

1. **FIXED AIRCRAFT SYMBOL:** The aircraft's attitude relative to the natural horizon is shown by the aircraft symbol and flight command bars. The pilot can adjust the symbol to one of three flight modes. To fly the aircraft with the command bars armed, the pilot simply inserts the aircraft symbol between the command bars.
2. **COMMAND BARS:** The command bars move up for a climb or down for descent, and roll left or right to provide lateral guidance. They display the computed angle of bank for standard-rate turns to enable the pilot to reach and fly a selected heading or track. The bars also show pitch commands that allow the pilot to capture and fly an ILS glide slope, a pre-selected pitch attitude, or maintain a selected barometric altitude. To comply with the directions indicated by the command bars, the pilot manoeuvres the aircraft to align the fixed symbol with the command bars. When not using the bars, the pilot can move them out of view.
3. **GLIDE SLOPE INDICATOR:** The glide slope deviation pointer represents the centre of the instrument landing system (ILS) glide slope and displays vertical deviation of the aircraft from the glide slope centre. The glide slope scale centreline shows aircraft position in relation to the glide slope.
4. **LOCALIZER DEVIATION POINTER:** The deviation pointer, a symbolic runway, represents the centre of the ILS localizer, and



FIG. 2-41 • FLIGHT DIRECTOR INDICATOR

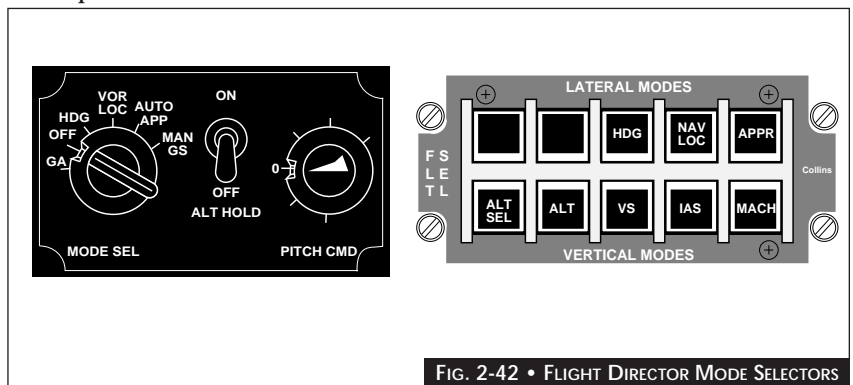

FIG. 2-42 • FLIGHT DIRECTOR MODE SELECTORS

comes into view when the pilot has acquired the glide slope. The expanded scale movement shows lateral deviation from the localizer and is approximately twice as sensitive as the lateral deviation bar in the horizontal situation indicator (refer to article 2.1.5C).

5. *SLIP INDICATOR:* This provides prompt slip or skid indications.
6. *FLIGHT DIRECTOR CONTROL PANEL:* The mode selector switch and control panel (Fig. 2-42) provides the input information used by the FDS to compute the command and display required for the FDI.

The pitch command control pre-sets the desired pitch angle of the aircraft for climb or descent. The *command bars* on the FDS then display the computed attitude to maintain the pre-selected pitch angle. The pilot may choose from among many modes including the HDG (heading) mode, the VOR/LOC (localizer tracking) mode, or the AUTO APP or G/S (automatic capture and tracking of ILS localizers and glide path) mode. The auto mode has a fully automatic pitch selection computer that takes into account aircraft performance and wind conditions, and operates once the pilot has reached the ILS glide slope. More sophisticated systems allow more flight director modes.

Turning the control clockwise commands a climb, and counter-clockwise, a descent. The GS (*manual glide slope*) mode allows the pilot to manually reach and maintain the glide slope through pitch command indications. The GA (*go around*) mode provides climb command information. The pilot places the command bars in a climb pitch, which is pre-set based on the aircraft performance and remains constant. The pilot may use the GA mode in conjunction with automatic throttle/speed control.

NOTE:

The manual glide slope selection normally is used when the pilot intercepts the slope from above.

The ALT HOLD (altitude hold) switch may be operated in the HDG and VOR/LOC

modes. Before the aircraft reaches the glide path, the pilot can also operate the switch in the AUTO APP mode. When engaged, pitch commands are referenced to the current barometric altitude indicated on the altimeter. The command bars on the FDI provide the climb or descent information required to maintain the altitude.

C. HORIZONTAL SITUATION INDICATOR

The horizontal situation indicator (HSI) was developed to assist pilots to interpret and use aircraft navigational aids. There are various types of HSIs, but each performs the same function. The HSI (Fig. 2-43) displays information obtained from combinations of the heading indicator, radio magnetic indicator (RMI), track indicator and range indicator. It may also display VOR, DME, ILS or ADF information.

The aircraft heading is displayed on a rotating compass card under the heading lubber line. The card is calibrated in 5° increments. The bearing pointer provides magnetic bearing information from the aircraft to the selected ground station (VOR or ADF). The fixed aircraft symbol and floating track bar display the aircraft's position relative to the selected track (VOR or ILS localizer).

When a VOR station is selected, the inner dot on the track bar azimuth scale indicates approximately 5° and the outer dot approximately 10° (the aircraft's operating manual should give details). In ILS applications the inner dot indicates approximately 1 1/4° and the outer dot approximately 2 1/2°, depending on the actual width of the localizer. The distance measuring equipment (DME) displays slant ranges in nautical miles to the selected DME station and, depending on the installation, may operate in the ILS Mode.

The pilot may adjust the track selector to indicate any of 360° tracks. To select a desired track, the pilot rotates the head of the track arrow by turning the track selector knob to the desired track on the compass



FIG. 2-43 • HORIZONTAL SITUATION INDICATOR

card, and then checks the track selector window for precise setting. When the *TO-FROM* indicator points to the head of the track arrow, it indicates that the selected track, if intercepted and flown, will lead the aircraft to the station. This may be reversed by selecting the reciprocal track on the compass card.

To intercept the inbound track, the pilot sets the desired track in the selector window and cross-checks the TO-FROM indicator to make sure that it points to the head of the track arrow. The pilot turns the aircraft in the shortest direction to an interception heading (normally 30-45°). The pilot then flies the intercept angle, ensuring that the head of the track arrow is in the top half of the HSI with an adequate interception angle. The bearing pointer should be between the heading lubber line and the head of the track arrow. The angle should not exceed 90° from the selected track.

For outbound tracking, the pilot selects the desired track in the selector window and ensures that the TO-FROM indicator points toward the tail of the track arrow. The pilot then turns the aircraft in the shortest direction to an interception track that places the head of the track arrow in the upper half of the HSI with a suitable interception angle (normally 45°).

Immediately after passing the station, the pilot intercepts the outbound track by turning the aircraft to parallel the track. The pilot sets the outbound track in the selector window. When the track bar and bearing pointer stabilize, the pilot notes the degrees off track and turns towards the track by this amount, allowing for wind drift. The intercept angle should not exceed 45°.

D. FLIGHT DIRECTOR COMPUTER

The basic flight director computer *receives information* from the:

- 1/ VOR/localizer/glideslope receiver;
- 2/ attitude gyro;
- 3/ radar altimeter;
- 4/ compass system;
- 5/ barometric sensors.

The computer uses this data to *provide steering command information* that enables the pilot to:

- 1/ fly a selected heading;

- 2/ fly a predetermined pitch attitude;
- 3/ maintain altitude;
- 4/ intercept a selected VOR or localizer track, and maintain that track;
- 5/ fly an ILS glide slope.

E. OTHER TYPES OF FLIGHT DIRECTOR SYSTEMS

Flight director systems vary greatly. In aircraft equipped with Flight Management Systems (FMS), the flight director is much more sophisticated and receives input from various sensors and one or more air data computers. Therefore, the pilot must consult the operating instructions for the particular aircraft model for specific information.

F. ELECTRONIC FLIGHT INSTRUMENT SYSTEM (EFIS)

EFIS refers to a system where conventional electro-mechanical flight instruments have been replaced by cathode ray tubes (CRT). These CRTs electronically display flight information in much the same presentation as electro-mechanical instruments but they also have the flexibility for selecting additional information to be added to the display and for altering the presentation.

The two most commonly used EFIS instruments are the *electronic horizontal situation indicator* (EHSI) and the *electronic attitude director indicator* (EADI) (Fig. 2-44 and Fig. 2-45). These can also be called an ND (Navigation Display) or a PFD (Primary Flight Display). The system may also include a multi-functional display (MFD) on a larger CRT which can provide expanded displays of HSI, radar, and navigation data from flight instruments and can include other data such as checklists, emergency procedures, etc. See Fig. 2-46. Data from various sources can be integrated into various combinations of displays depending on the equipment installed.

The EFIS uses input data from several sources including:

- 1/ VOR/localizer/glideslope/TACAN/micro-wave landing system (MLS) receiver;



FIG. 2-44 • EFIS PRIMARY FLIGHT DISPLAY

- 2/ pitch, roll, and heading rate, and acceleration data from an Attitude Heading System (AHS) or conventional vertical gyro, compass system, and longitudinal accelerometer;
- 3/ radar altimeter;
- 4/ air data system;
- 5/ DME;
- 6/ area navigation system (RNAV) (i.e., ONS, INS, VLF, LORAN, GPS, etc.);
- 7/ vertical navigation system;
- 8/ weather radar system; and
- 9/ ADF.

A typical EFIS is composed of a Primary Flight Display, a Navigation Display, a Display Select Panel, a Display Processor Unit, a Weather Radar Panel, a Multifunction Display, and a Multifunction Processor Unit.

1. **PRIMARY FLIGHT DISPLAY (PFD):** The typical PFD is a multicolor CRT or LCD display unit that presents a display of aircraft attitude and flight control system steering commands including VOR, localizer, TACAN, or RNAV deviation; and glideslope or preselected altitude deviation. Flight control system mode annunciation, autopilot engage annunciation, attitude source annunciation, marker beacon annunciation, radar altitude, decision height set and annunciation, fast-slow deviation or angle-altitude alert, and excessive ILS deviation (when Category II configured) can also be displayed. (See Fig. 2-44).
2. **NAVIGATION DISPLAY (ND):** The typical ND is a multicolor CRT or LCD display unit that presents a plan view of the aircraft horizontal navigation situation. Information displayed includes compass heading, selected heading, selected VOR, localizer, or RNAV course and deviation (including annunciation or deviation type), navigation source annunciation, digital selected course/desired track readout, excessive ILS deviation (when Category II configured), to/from information, back course localizer annunciation, distance to station/waypoint, glideslope MGP, or VNAV deviation ground speed, time-to-go, elapsed time or wind, course information and source annunciation from a second

navigation source, weather radar target alert, waypoint alert when RNAV is the navigation source, and a bearing pointer that can be driven by VOR, RNAV or ADF sources as selected on the display select panel. The ND can also be operated in an approach format or an en route format with or without weather radar information included in the display. (See Fig. 2-45).



FIG. 2-45 • EFIS NAVIGATION DISPLAY

3. **DISPLAY SELECT PANEL (DSP):** The display select panel provides navigation sensor selection, bearing pointer selection, format selection, navigation data selection (ground speed, time-to-go, time, and wind direction/speed), and the selection of VNAV (if the airplane has a VNAV system), weather, or second navigation source on the ND. A DH SET knob that allows decision height to be set on the PFD is also provided. Additionally, course, course direct to, heading, and heading sync are selected from the DSP.
4. **DISPLAY PROCESSOR UNIT (DPU):** The display processor unit provides sensor input processing and switching, the necessary deflection and video signals, and power for the electronic flight displays. The DPU is capable of driving two electronic flight displays with different deflection and video signals. For example, a PFD on one display and an ND on the other.
5. **WEATHER RADAR PANEL (WXP):** The weather radar panel provides MODE control (OFF, STBY, TEST, NORM, WX, and MAP), RANGE selection (10, 25, 50, 100, 200 and 300 nm), and system operating controls for the display of weather radar information on the MFD and the ND's when RDR is selected on the MFD and/or the display select panel.



FIG. 2-46 • OTHER DATA ON EFIS DISPLAYS

6. **MULTIFUNCTION DISPLAY (MFD):** The multifunction display is a multicolor CRT or LCD display unit that mounts in the instrument panel in the space normally provided for the weather radar indicator. Standard functions displayed by the unit include weather radar, pictorial navigation map, and in some systems, check list and other operating data. Additionally, the MFD can display flight data or nav data in case of the malfunction in either of the PFD's or ND's (See Fig. 2-46).
7. **MULTIFUNCTION PROCESSOR UNIT (MPU):** The multifunction processor unit provides sensor input processing and switching and the necessary deflection and video signals for the multifunction display. The MPU can provide the deflection and video signals to the PFD and ND displays in the event of failures to either or both display processor units.

EFIS Features

EFIS furnishes the pilot with the following common features:

- a/ large easy to interpret 5 in. by 5 in. or 5 in. by 6 in. displays for PFD and ND's;
- b/ displays that have superior readability even under full sunlight cockpit lighting conditions;
- c/ full screen earth/sky representation on the PFD adds to the realism of the attitude display;
- d/ display only the data needed at the time it is needed; for example, GS, LOC and radar altitude can be shown during approach and removed en route to decrease display clutter;
- e/ strapping options allow selecting V bar or crosspointer presentations on the PFD, and the addition of a speed command display;
- f/ multifunction, pilot selectable ND formats; for example, full compass rose or sectored rose (approach or en route modes) with or without weather radar; and
- g/ superior autopilot/flight director mode and NAV source annunciation.

NOTE:

This chapter has dealt very generally with a generic EFIS. It is important that specific aircraft operating procedures be consulted for detailed information.

2.1.6 MISCELLANEOUS INSTRUMENTS

A. TRAFFIC ALERT AND COLLISION AVOIDANCE SYSTEM (TCAS)

1. **OVERVIEW:** The Traffic Alert and Collision Avoidance System (TCAS) is an independent airborne system. It is also known as Airborne Collision Avoidance System (ACAS). It is designed to act as a backup to the ATC system and the "see and avoid" concept. TCAS consists of four aircraft-mounted antennas, a TCAS Computer Unit and Mode S Transponder, and displays and controls in the cockpit. TCAS II continually surveys the airspace around an aircraft, seeking replies from other aircraft in the vicinity via their ATC transponders. The transponder replies are tracked by the TCAS system. Flight paths are predicted based upon these tracks. Paths predicted to penetrate a Collision Area surrounding the TCAS II aircraft are annunciated by TCAS. TCAS generates two types of annunciations: a *Traffic Advisory* or TA and a *Resolution Advisory* or RA. TCAS provides a time based alert in that the physical dimensions of a Caution Area will vary as a function of closure speed (see Fig. 2-47).

TCAS continuously calculates tracked aircraft projected positions. TAs and RAs are therefore constantly updated and provide real time advisory and position information.

A *Traffic Advisory* is displayed 35-48 seconds from the time the intruder aircraft is predicted to enter the TCAS aircraft's collision area. The traffic displayed includes the range, bearing and altitude of the intruder relative to the TCAS aircraft. The

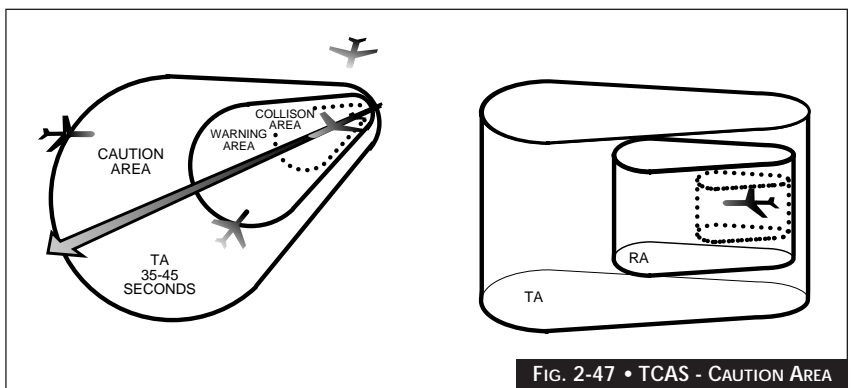

FIG. 2-47 • TCAS - CAUTION AREA

flight crew is to use this information as an aid to visually locate the intruder in order to avoid a conflict.

TCAS II also monitors a time based dimension of a Warning Area that extends 20-30 seconds from the time at which an intruder would enter the TCAS aircraft's collision area. Should an intruder enter the *Warning Area*, an escape strategy in the form of a *Resolution Advisory* is issued by the system. The Resolution Advisory is a vertical manoeuvre recommended to be performed or to be avoided by TCAS II in order to increase or maintain vertical separation relative to an intruding aircraft. TCAS III can also order horizontal manoeuvres. The RA will be annunciated both visually and aurally. It will consist of either a corrective advisory, calling for a change in aircraft vertical speed, or a preventive advisory, restricting vertical speed changes.

Once the flight path of the intruder no longer conflicts with the collision area of the TCAS aircraft, TCAS will announce "CLEAR OF CONFLICT" to confirm the encounter has ended. The flight crew should then return to the original clearance profile.

TCAS generates Resolution Advisories and Traffic Advisories against intruder aircraft with ATC transponders replying in Mode C and Mode S. These include altitude in their transmissions. TCAS uses the altitude information for Resolution Advisory computations. TCAS can generate only Traffic Advisories against intruder aircraft whose transponders reply in Mode A (non-altitude reporting).

WARNING:

TCAS cannot provide an alert for traffic conflicts with aircraft without operating transponders.

2. **TCAS TRAFFIC ADVISORY DISPLAY:** TCAS traffic can be displayed on a liquid crystal, flat panel TA/RA/VSI which replaces the conventional IVSI (Fig. 2-48). In this indicator the VERTICAL SPEED INDICATOR (VSI) takes on the additional

function of displaying traffic and Resolution Advisories, in addition to other traffic information designed to improve situation awareness. Internal switching of TCAS automatically presents a TCAS Traffic Display on the VSI when a Traffic Advisory is necessary.

A white airplane symbol is displayed in the lower centre of the VSI representing your TCAS-equipped aircraft. A white range ring made up of 12 dots, each corresponding to a normal clock position, is included. The range ring surrounds the airplane with a radius of 2 nautical miles and is intended to assist in interpreting TCAS traffic information.



TCAS provides colour-coded visual advisory areas just inside, and adjacent to, the VSI scale. These colour-coded indications instruct the pilot what vertical speed region is TO BE AVOIDED (RED). If a change in vertical speed is necessary, the specific region of vertical speed the pilot is to "fly-to" is illuminated in GREEN. For example, in the event of the corrective advisory message "CLIMB - CLIMB - CLIMB", the PROHIBITED RED Vertical Speed region may extend from the extreme limit of descent to +1500 FPM as illustrated in Fig. 2-48. The GREEN "fly-to" area appears from +1500 fpm to +2000 fpm.

In Fig. 2-48, resolution advisory (RA) traffic (*red square*) is shown as 300 feet below and descending. Traffic advisory (TA) traffic (*yellow circle*) is shown as 500 feet below and descending while proximate traffic (*cyan diamond*) is shown as 1200 feet below and descending.

3. **PILOT CONSIDERATIONS:** Anytime a pilot deviates from a cleared altitude to follow a TCAS Resolution Advisory he or she should inform ATC as soon as possible of the deviation and return to the assigned altitude as soon as possible after the traffic has passed. Ground Proximity Warning Systems (GPWS) advisories take precedence over TCAS advisories.

If stick shaker occurs during an RA manoeuvre, the pilot should immediately abandon the RA manoeuvre and execute the stall recovery procedure.

B. HEAD-UP DISPLAY (HUD)

A head-up display (HUD) is an electro-optical device which displays flight information near the front windscreen so that the pilot can simultaneously monitor aircraft instruments and the outside (forward) environment.

PRESENTATION

A HUD receives aircraft control, performance and navigation data from on-board computers and sensors. The information received is then projected onto a combining glass for head-up viewing. HUD symbology is focused at infinity for optimum effectiveness and pilot comfort. Often, information is presented in digital form. Aircraft pitch information is displayed as stylized pitch lines (pitch ladder).

ADVANTAGES

The most significant advantage of a HUD is the ability of the pilot to monitor flight and navigation data while being “head-up”. This advantage is intuitively obvious in the situation of an approach to an airport in IMC near minimums, or while flying in VMC in a busy terminal area. Aircraft control is less likely to suffer while the pilot is looking for the runway environment, and the transition from instruments to visual references is easier.

DISADVANTAGES

Multitudes of information can be displayed on a HUD (Fig. 2-49). However, the size limitation of a HUD display has an enormous effect on the “user friendliness” of a HUD. If analogue displays are used the symbology becomes very active and cluttered. If digital displays are used the pilot is denied quick trend information thereby increasing pilot workload during flight. Digital airspeed and altitude readouts cause the greatest consternation. In the very latest generation of aircraft, this problem has been somewhat overcome with the adoption of the “wide-angle” HUD.

Although the centralization of information on a HUD reduces the amount of head movements required during instrument flight, the cross-check can break down if the pilot does not

continue a disciplined scan of individual readouts within the HUD. Because the symbols displayed on the HUD are relatively small and very close together there appears to be a subconscious tendency to stare at the HUD without actually being aware of flight parameters (“magic fixation”).

A HUD requires a suitable background in order for the pilot to see the projected display. “Washout” of HUD symbology can occur in high light intensity situations such as when pointing into the sun or when on short final at night (due to runway and approach lighting). Also, because of the nature of a HUD, coloured backgrounds cannot be used to enhance the display. For instance, the difference between a nose high and nose low pitch attitude is not as apparent (in IMC) looking at a HUD as it is looking at a conventional attitude indicator with its blue sky and black ground hemispheres.

An additional problem with a HUD occurs when the background lighting intensity constantly changes, as when flying in and out of cloud or precipitation. Prolonged exposure to

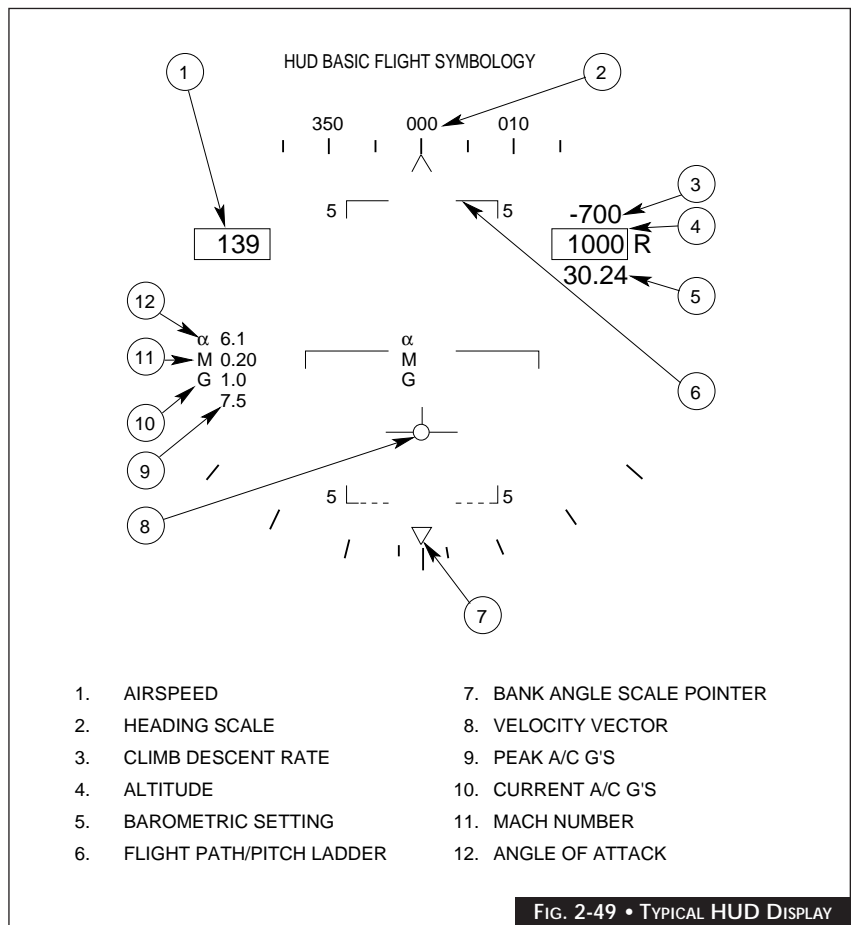

FIG. 2-49 • TYPICAL HUD DISPLAY

this situation can cause eye fatigue and in extreme cases may cause air sickness or disorientation.

SUMMARY

Although the HUD is a less-than-perfect electro-optical system, the benefits of a HUD far outweigh the disadvantages. For this reason some new transport aircraft are HUD equipped.

C. WEATHER RADAR

This section will provide a brief overview of weather radar from theory of operation to operation in-flight. The use of weather radar is often the most effective way of avoiding severe weather in the IFR environment. Although ATC makes every effort to advise pilots of areas of severe weather and steer them around it, it is the pilot's responsibility to avoid severe weather.

CAUTION:

Weather radar should not be operated during refuelling or when people on the ground are within at least 50 feet of the nose of the aircraft. See the Aircraft Flight Manual for more details.

THEORY OF OPERATION

The primary use of weather radar is to aid the pilot in avoiding thunderstorms and associated turbulence. It is *for avoiding - not penetrating* - severe weather. Whether to fly into an area of radar echoes depends on echo intensity, spacing between the echoes, and the capabilities of both pilot and aircraft. Remember that weather radar detects only precipitation drops; it does not detect minute cloud droplets. A clear area on the radar screen does not mean that this area does not contain cloud.

The geometry of the weather radar radiated beam precludes its use for reliable proximity warning or anti-collision protection. The beam is characterized as a cone-shaped pencil beam much like that of a flashlight or spotlight beam.

As mentioned earlier, only precipitation (or objects more dense than water such as earth or solid structures) will be displayed on the indicator. The best radar reflectors are raindrops and wet hail. The larger the raindrop, the better it reflects. Because large drops in a concentrated area are characteristic of a thunderstorm, the radar displays the storm as a

strong echo. Generally, ice, dry snow and dry hail have low reflective levels and often will not be displayed by the radar.

Colour radars show intensity of echoes by using colours, usually red or magenta as the most severe (Fig. 2-50). Monochrome radars use the brightness of the display to indicate intensity.

Extreme weather can usually be identified by characteristic patterns: (1) fingers and protrusions; (2) hooks; (3) scalloped edges; and (4) U-shaped cloud edges.

ATTENUATION

An extremely important phenomenon for the pilot to understand is that of attenuation. When a radar pulse is transmitted into the atmosphere, it is progressively absorbed and scattered so that it loses its ability to return to the antenna. This attenuation or weakening of the radar pulse is caused by two primary sources: distance and precipitation.

Attenuation because of *distance* is due to the fact that the radar energy leaving the antenna is inversely proportional to the square of the distance. For example, the reflected radar energy from a target 60 miles away will be one-fourth of the reflected energy from a target 30 miles away.

Attenuation due to *precipitation* is far more intense and is less predictable. Since some of the beam energy is absorbed by precipitation, the beam may not reach completely through the area of precipitation. If the beam has been fully attenuated, the radar display will show a "*radar shadow*" which appears as an end to the precipitation when, in fact, the heavy rain may extend for many more miles.

OPERATION IN-FLIGHT

Effective *tilt management* is the single most important key to more informative weather radar displays. Three factors should be remembered when using tilt controls:

- 1/ the earth's curvature, especially at long distances;
- 2/ the radar beam is referenced to the horizon by the aircraft's vertical reference system;

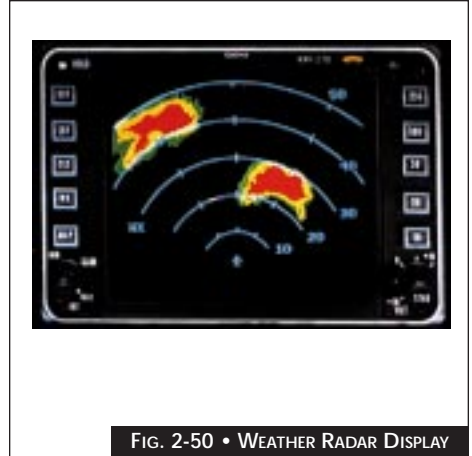

FIG. 2-50 • WEATHER RADAR DISPLAY

3/ adjusting the tilt control causes the beam to scan above or below the plane of the attitude reference system.

In planning deviations, remember to plan for the deviation early. The following are some considerations for *planning your deviation*.

- 1/ avoid the brightest returns (or red or magenta in a colour radar) by at least 20 miles;
- 2/ do not deviate downwind unless absolutely necessary;
- 3/ when looking for a corridor, ensure it is at least 40 miles wide if it is between two severe cells;
- 4/ a "blind alley" or "box canyon" situation can be avoided by switching to the longer ranges to observe distant conditions from time to time.

NOTE:

See the *Air Command Weather Manual* for a more detailed explanation.

SUMMARY

To master the use of weather radar takes time and patience as well as understanding the particular characteristics of the radar set you operate. Use the operating handbook for your particular system to ensure greatest safety.

STORMSCOPE

The Stormscope (Fig. 2-51) is a weather avoidance system that detects electrical discharges from thunderstorms and presents them on a display, usually a cathode ray tube (CRT). The system normally consists of an antenna, a system processor, and the CRT.

The loop and sense antenna detects electrical and magnetic fields produced by lightning. The high-speed processor uses information from the antenna to determine distance and direction of electrical discharges about the aircraft.

A green CRT displays a lightning discharge as an individual point; a dense arrangement of points indicates severe weather. The CRT operates in various ranges: 25, 50, 100 and 200 nm being a standard set-up.

D. MODE "S" TRANSPONDER

The Mode S transponder is the latest generation transponder and is now the standard required for

carriage in transport aircraft. The Mode S transponder provides the functions of existing ATCRBS transponders (Modes A and C; identification and altitude reporting) but because of its design characteristics, is able to do so in a more efficient manner.

Each Mode S transponder is assigned its own unique 24-bit interrogation address which allows it to be individually interrogated. The use of 24-bit address provides for more than 16 million different addresses, enough to ensure no duplication occurs.

Each interrogation contains the unique address of the aircraft for which it is intended. A Mode S transponder receiving an interrogation examines it for its own address. If the address corresponds, the transponder generates and transmits the necessary reply; all other aircraft ignore the interrogation.

This type of interrogation management ensures that no overlapping replies arrive at the interrogator's antenna (synchronous garbling) and prevents random replies from interrogators with overlapping areas of coverage (fruit). This technique improves Secondary Surveillance Radar (SSR) performance and increases system capacity.

An additional characteristic of the Mode S transponder is its ability to provide two-way air-to-air and ground-to-air *data link* communications. These messages are passed on the two existing transponder frequencies (1030 MHz and 1090 MHz). The air-to-air feature of the data link is required to pass complementary manoeuvre messages between two or more TCAS-equipped aircraft which may select the same traffic avoidance manoeuvre.

The two-way air-to-ground capability, requiring appropriate ground and aircraft equipment, can facilitate the transmission of air traffic services and other operational messages. The system will act as a back-up to existing VHF voice network and will improve the system safety by reducing



FIG. 2-51 • STORMSCOPE



FIG. 2-52 • INSTRUMENT COMPARATOR

communication-related errors within the ATC system.

The operation of Mode S transponders by the flight crew is identical to conventional transponders (Mode A/C). The setting of the 24-bit unique address is a maintenance function related to the registration of the aircraft. The Mode S transponder is required for TCAS II operation.

E. GROUND PROXIMITY WARNING SYSTEM (GPWS)

The Ground Proximity Warning System provides alert of possible terrain danger. *Visual and aural warnings* are provided under any of the following conditions:

- 1/ excessive rate of descent with respect to terrain;
- 2/ excessive closure rate to terrain;
- 3/ negative climb rate after takeoff or missed approach before attaining suitable terrain clearance with landing gear up; and
- 4/ approach too close to terrain with landing gear up after attaining suitable terrain clearance.

When a warning occurs, smoothly pull up and apply engine thrust until the warning ceases. Climb at the maximum practical rate until the warning ceases or terrain clearance is assured. Determine the cause of the warning if possible.

F. INSTRUMENT COMPARATOR

An instrument comparator system as displayed in Fig. 2-52 is designed to alert pilots to a disagreement between the captain's and co-pilot's instruments. When their instruments disagree by more than a pre-set amount, the appropriate button on the comparator illuminates to warn the pilots. For instance, if the heading (HDG) button illuminates, the pilots should check the compasses and determine which system is not reading correctly.

2.2 RADIO NAVIGATION SYSTEMS

2.2.1 INTRODUCTION

The purpose of this section is to describe the nature and operation of basic radio navigation systems used on board aircraft. Advantages, limitations, components and basic pilot procedures are presented for six types of systems - VOR, DME, ADF, ILS, MLS, and various RNAV systems.

2.2.2 NAVIGATIONAL AIDS (NAVAIDS)

A. RADIO THEORY

Some basic radio theory is provided to give a better understanding of the operation of radio navigation systems and associated terminology.

1. WAVE CHARACTERISTICS (Fig. 2-53)

Cycle is the interval between any two points measuring the completion of a single wave movement.

Wavelength is the actual linear measurement, in metres, of one wave.

Amplitude is the strength, or width, of one wave; it decreases with distance from the transmitting site.

Frequency is the number of cycles per second. It is expressed in the following units:

Kilohertz (KHz) - thousands of cycles per second;

Megahertz (MHz) - millions of cycles per second;

Gigahertz (GHz) - billions of cycles per second.

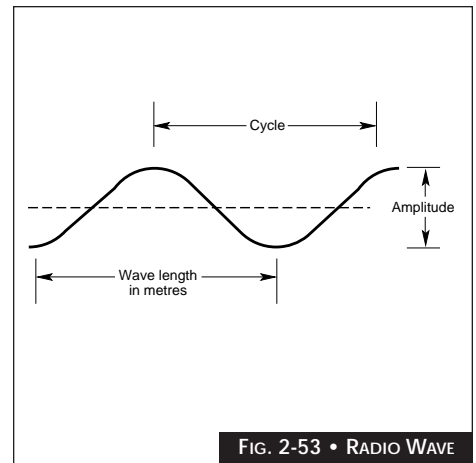

FIG. 2-53 • RADIO WAVE

2. **RADIO FREQUENCY CATEGORIES:** Radio frequency categories are shown in Fig. 2-54.
3. **RADIO WAVES:** Radio waves are radiated energy. In free space, they travel in straight lines at the *speed of light* (approximately 186,000 miles per second). They have the same characteristics as light and heat waves, but are lower in frequency.

They may be subject to the following:

- a/ **Reflection.** A change in direction of travel of a wave occurs at the surface separating two different media. Whenever reflection occurs the angle of incidence equals the angle of reflection;
- b/ **Refraction.** The bending of a wave as it passes obliquely from one medium to another or through a single medium of varying density;
- c/ **Diffraction.** Bending which occurs when a wave grazes the edge of a solid object through which it cannot pass; and
- d/ **Attenuation.** The loss of wave energy as it travels through a medium. All matter has a varying degree of conductivity or resistance to the transmission of radio waves. The earth and objects on it attenuate radio waves as do molecules of air, water and dust in the atmosphere.

The following terms are used in discussing the transmission of radio waves (Fig. 2-55).

- a/ **Ionosphere.** Layers of rarified ionized gas believed to be caused by ultra-violet solar radiation. They range from

approximately 60 to 200 miles above the earth and vary according to time of day, season, and latitude;

- b/ **Ground Waves.** Part of the transmitted radiation that follows the surface of the earth and is directly affected by the earth and its surface features. Ground waves are not subject to ionospheric or weather changes, but suffer from surface attenuation which is directly proportional to the frequency. (The lower the frequency, the less the attenuation for a given power);
- c/ **Space Waves.** Part of the transmitted radiation that does not follow the curvature of the earth or bend around obstructions, but generally travels outwards or upwards from the transmitter;
- d/ **Sky Waves.** Part of the transmitted radiation that is reflected or refracted from the ionosphere. A sky wave, when reflected/refracted back by the ionospheric layer, will continue to reflect between earth and sky until completely attenuated;
- e/ **Skip Distance.** The distance between the transmitter and the point where the first sky wave returns to earth. It depends upon the height and density of the ionosphere. Great changes in skip distance occur at dawn and dusk as solar radiation varies the position and density of the ionosphere; and
- f/ **Skip Zone.** The distance between the end of the useful ground wave and the point where the sky wave is returned to earth.

DESCRIPTION	ABBREVIATION	FREQUENCY	WAVELENGTH
Very low frequency	VLF	3 KHz - 30 KHz	100,000M - 10,000M
Low frequency	LF	30 KHz - 300 KHz	10,000 M - 1,000M
Medium frequency	MF	300 KHz - 3 MHz	1,000M - 100M
High frequency	HF	3 MHz - 30 MHz	100M - 10M
Very high frequency	VHF	30 MHz - 300 MHz	10M - 1M
Ultra high frequency	UHF	300 MHz - 3 GHz	1M - 0.10M
Super high frequency	SHF	3 GHz - 30 GHz	0.10M - 0.01M
Extremely high frequency	EHF	30 GHz - 300 GHz	0.01M - 0.001M

FIG. 2-54 • TABLE OF RADIO FREQUENCIES

4. **RADIO PROPAGATION:** Depending upon the frequency of the radiated signal, radio energy is most efficiently propagated by only one of the three main methods - *ground, space* or *sky* waves. The following general rules apply:
 - a/ up to about 3 MHz (VLF, LF and MF) ground wave transmission predominates, although sky waves are used for longer distances;
 - b/ from 3 to 30 MHz (HF) the range of the ground wave decreases rapidly and sky waves are the primary method;
 - c/ above 30 MHz (VHF, UHF, SHF and EHF) propagation is line-of-sight (space waves), modified by the reflecting effects of various objects on the earth. The transmission path is generally predictable. Ground waves rapidly attenuate, the sky waves rarely exist;
 - d/ from 100 MHz (upper VHF and UHF) the transmission path is highly predictable and not affected by time of day, season, precipitation or atmospheric conditions; and
 - e/ above 3 GHz (SHF and EHF), some attenuation and scattering is caused by precipitation and the atmosphere.

5. **INTERFERENCE TO AIRCRAFT NAVIGATIONAL EQUIPMENT:** The radiation produced by frequency modulation (FM) and television (TV) broadcast receivers was found to fall within the ILS localizer and VOR frequency band while the radiation produced by the amplitude modulation (AM) Broadcast receivers was found to fall within the broadcast band between 98 Khz and 1600 Khz. This radiation could interfere with the correct operation of ILS, VOR and ADF equipment.

Pilots of aircraft are therefore cautioned against permitting the operation of either portable radio, television or cellular phones on board their aircraft at any time.

The Department of Communications has, after extensive testing, concluded that the

switching on or use of hand-held electronic calculators can cause interference to air navigation ADF equipment in the 200-450 kHz frequency range when the calculator is held or positioned within 5 feet of the loop or sense antenna, or lead-in cable installation of the system.

Pilots, especially of small aircraft and helicopters, are therefore cautioned against allowing the operation of *calculators* on board their aircraft while airborne, and are to ensure that if carried, the switch of the calculator is in the off position.

Cellular phones have also been shown to interfere with aircraft instruments and should not be allowed. *Sky phones* which are designed for aircraft use are acceptable.

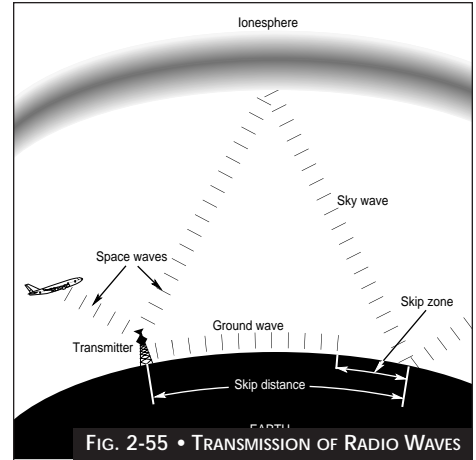

B. VERY - HIGH - AND ULTRA - HIGH - FREQUENCY RADIO AIDS

1. **VOR:** The VHF Omnidirectional Range (VOR) operates in the frequency band 108.1 to 117.95 Mhz, which is relatively free from static and interference. At minimum instrument altitudes, it gives reliable indications at approximately 50 NM from the station. Normally the VOR may be received 150 NM to 200 NM from the transmitter at high altitudes.

The VOR provides guidance on any track to or from the station. This is why it is called an omni (directional) range.

All Canadian VOR stations operate continuously, and some have a simultaneous voice feature used for emergency air-ground communications and weather broadcasts. Station identification consists of the three-letter station identifier keyed in Morse code at regular intervals. At some locations the VOR voice channel is used to transmit the ATIS broadcast.

The accuracy of track alignment of the omni-range is within a tolerance of +3°. At



certain stations some sectors may contain large errors. These sections are indicated in the remarks column of the station listings in the *Canada Flight Supplement*.

2. **TACAN:** The Tactical Air Navigation System (TACAN) is an ultra high-frequency (UHF) omni-directional navigational aid that provides slant distance, in nautical miles from a ground station to an aircraft, and the azimuth in degrees from the station. Stations are normally referenced to magnetic north. Equipment consists of a ground station transponder and an airborne receiver/transmitter. The system has a range of up to 200 NM, depending on aircraft altitude.

Canadian TACAN stations are owned and operated by the Department of National Defence. Paired VOR frequencies are published on Canadian Aeronautical Charts to allow civil pilots flying DME equipped aircraft to use the DME function of TACAN.

3. **VORTAC:** This is a combination of a VOR and TACAN at one location. VORTAC provides azimuth navigational information on VHF, and azimuth and distance information on UHF. Separate TACAN airborne equipment is needed to obtain azimuth data from the TACAN part of the system.

Department of National Defence TACAN facilities co-located with Transport Canada VORs are operated and maintained by Transport Canada.

4. **VHF DIRECTION FINDING:** VDF equipment has been established at a number of FSSs and airport control towers. VDF normally operates on pre-selected frequencies in the 115 to 144 Mhz range. Information displayed to the controller or FSS position on a numerical readout gives an accurate (+2°) visual indication of the bearing of an aircraft from the VDF site. This is based on the radio transmission received from the aircraft, thus giving the VDF operator a means of providing steering, bearing or homing information to pilots requesting the service.

- a/ **Primary Services**
Directional guidance to the VDF and, if requested, a bearing from the VDF site.

- b/ **Additional Services**
Track out assistance, estimated times or distances from the site, or fixes when used in conjunction with other VDF site, a VOR radial or a bearing from an NDB.

- c/ **Emergency Service**
Cloud breaking procedures and no compass homing will be provided when no other course of action is available provided the pilot declares an emergency, or accepts the service suggested by the VDF operator.

5. **OMNITEST OR VOR EQUIPMENT TEST (VOT):** Low-power (2 W) VHF omnitest transmitters are installed at a number of airports to check the accuracy of VOR receivers while aircraft are on the ground. Identification consists of a series of dots.

The VOT radiates a “NORTH” bearing signal on all azimuths that simulates, in the cockpit, a position on the magnetic north (000) radial from the VOR facility. The bearing accuracy of the transmitted signal is maintained within a tolerance of 1°. The aircraft equipment check is described in Article 2.2.3B.

C. RADAR SYSTEMS

Primary Surveillance Radar (PSR) detects and reports reflections of aircraft weather, flocks of birds, stationary objects, approximate range of 80 NM.

Secondary Surveillance Radar (SSR) transmits an “interrogation beam” to which an airplane transponder responds, range of 250 NM.

Terminal Surveillance Radar (TSR) systems with both PSR and SSR information, they are capable of digitizing primary radar targets including weather data for presentation.

Independent Secondary Surveillance Radar (ISSR) systems which only provide SSR information.

Radar Digitized Display (RDD-1) is a radar system that uses SSR data remoted from a radar site for display at an area control centre. This system does not display weather or non-transponder equipped aircraft.

D. PRECAUTIONARY USE OF NAVIGATION AIDS

Radio beacons sometimes are subject to disturbances that cause NDB needle deviations, signal fades and interference from distant stations, particularly during night operations. Pilots should be alert for these problems, especially over mountainous terrain.

At times, pilots may observe minor course needle fluctuations and brief flag alarm signals on some VORs. (Some VHF receivers are more susceptible to these irregularities than others). Helicopter rotor speeds and certain propeller RPM settings can cause VOR course fluctuations. Slight changes to the RPM setting will normally smooth out this roughness. Pilots operating over unfamiliar routes should use the TO-FROM indicator to determine positive station passage.

Pilots may encounter random glide path signals when undertaking back course ILS approaches at certain airports. Pilots should ignore all glide path indications when using localizer back courses.

False localizer signals may also occur when outside the localizer area of reliable signal coverage. See Article 2.2.7 for further details.

When pilots observe apparent abnormal operation of any navigation aid facility, they should report it to the appropriate flight service station, tower, terminal control unit, or ATC centre. If it is not practicable to report it at the time, the pilot may report the trouble after landing.

Reports on *course shifts* are more useful to technical staff if they contain:

- 1/ the approximate magnitude of the shift, either in miles or degrees from the published bearing;
- 2/ the direction of the shift;
- 3/ the approximate distance from the aid at which the observation was made.

Reports concerning the *failure of a ground facility* to reply should include the date, time, the location of the aircraft, and a brief description of reception and weather conditions at the time.

**2.2.3
VOR NAVIGATION**

A. GENERAL

The airway system is based primarily on the very high frequency omnidirectional range (VOR). This extensive system consists of several hundred ground stations that transmit navigation track guidance signals used by aircraft in flight.

The VOR navigational system has many advantages for the IFR pilot. The VOR transmits in the very high frequency range of 108.1 through 117.95 MegaHertz (MHz); therefore, it is relatively free from precipitation static and annoying interference caused by storms or other weather phenomena. *Accuracy* is another advantage: a track accuracy of plus or minus 1° is possible when flying a VOR radial. Wind drift is compensated for by flying to centre the track bar indicator.

VOR signals are transmitted on line-of-sight. Any obstacles (buildings, mountains or other terrain features, including the curvature of the earth) block VOR signals and restrict the distance over which they are received at a given altitude. This can result in "*scalloping*" - a sudden fluctuation of the cockpit indicators - normally for short time intervals. Certain terrain features may produce areas where VOR navigation signals are unusable, so every instrument pilot making an "off airways" flight should be aware of the restrictions along the route.

Because of greater reception distances at higher altitudes, it is possible for an aircraft to receive erroneous indications due to the reception of two VOR stations operating on the same frequency. Stations on the same frequency are spaced as far apart as possible, but there are, nevertheless, more VORs than the 160 frequencies available. The solution has been to design and classify VORs according to the usable cylindrical service volume.



This is the system by which VOR frequencies are assigned to stations far enough apart to prevent overlapping, confusing signals. As long as pilots use the proper chart, they are protected from interference between two VORs. The pilot uses low-altitude charts below 18,000 ft and the high-altitude charts at and above 18,000 ft.

B. VOR ACCURACY

1. **REQUIREMENTS FOR CHECKS:** The *Air Regulations* and good judgement dictate that the VOR equipment of aircraft flying under instrument flight rules be within specified tolerances. Airborne VOR equipment used on IFR flights must be maintained, checked and inspected under an approved procedure. The pilot normally makes these operational checks. In preparing for an IFR flight the pilot should check the aircraft log, then make a physical check on the appropriate VOT (test) frequency to determine whether the VOR equipment meets accuracy requirements.
2. **VOR TEST FACILITY:** The first method is to use a VOR test facility signal (VOT). This is an approved test signal, located on an airport, that enables the pilot to check the receivers conveniently and accurately. First, the pilot should tune the VOR receiver to the VOT frequency. These frequencies are coded with a series of Morse code dots or a continuous 1020-cycle tone. When the pilot sets the course selector to 0°, the track bar (TB) indicator should centre and the TO-FROM indicator should read FROM. Then the pilot sets the selector to 180°. The TO-FROM indicator should read TO and the TB should be centred.

The pilot determines the exact error in the receiver by turning the track selector until the TB is centred, and noting the degrees difference between 180° or 0°. The *maximum permissible bearing error* with this system check is plus or minus 4°. Apparent errors greater than 4° indicate that the aircraft receiver is beyond acceptable tolerance. In such circumstances the pilot should determine the cause of the error and have it corrected before attempting IFR flight.

The airports with VOT facilities are listed in the *Canada Air Pilot* and the *Canada Flight Supplement*, Airport/Facility Directory. Because the VOT signal is only a special test signal, it may be received and used regardless of the aircraft's position on the airport.

3. **VOR CHECK POINT SIGNS:** A number of aerodromes have VOR check point signs located beside taxiways. These signs indicate a point on the aerodrome where there is sufficient signal strength from a VOR to check aircraft VOR equipment against the radial designated on the sign. Frequently a DME distance will also be indicated for check purposes. The maximum permissible difference between aircraft equipment and the designated radial is 4° and 0.5 NM of the posted distance.
4. **DUAL VOR CHECK:** If neither a test signal (VOT) nor a designated check point on the surface is available and an aircraft is equipped with dual VORs (units independent of each other except for the antenna), the equipment may be checked against each other by tuning both sets of the same VOR facility and noting the indicated bearings to that station. A difference greater than 4° between the aircraft's two VOR receivers indicate that one of the aircraft's receivers may be beyond acceptable tolerance. In such circumstances, the cause of the error should be investigated and, if necessary, corrected before the equipment is used for an IFR flight.
5. **AIRBORNE VOR CHECK:** Aircraft VOR equipment may also be checked while airborne by flying over a fix or landmark located on a published radial and noting the indicated radial. Equipment which varies more than 6° from the published radial should not be used for IFR navigation.

C. AIRCRAFT VOR COMPONENTS

1. **VOR RECEIVER:** In many modern aircraft one control unit is used for both the VOR



FIG. 2-56 • NAVCOM CONTROL PANELS

receiver and the VHF communications transceiver. When located together, the radio is called a NAVCOM (Fig. 2-56). The VOR signals are received on the antenna, normally located on the vertical stabilizer or on top of the fuselage. This antenna resembles a “V” lying in a horizontal plane. The VOR receiver converts signals from the antenna to the readings displayed on the navigation indicator.

2. **NAVIGATION INDICATOR:** The VOR navigation indicator gives the pilot aircraft position information by means of three components. The track selector, sometimes called the *omnibearing selector* or OBS, is used to rotate the azimuth ring, which displays the selected VOR track, (Fig. 2-57). This ring may also show the reciprocal of the selected track.

The TO-FROM/OFF flag indicates whether the track will take the pilot to or from the station. If the aircraft is out of station range and cannot receive a reliable, usable signal, the TO-FROM/OFF indicator displays OFF. Also, the OFF flag is displayed when the aircraft is directly over the station, when abeam of the station in the area of ambiguity (i.e., directly on either side of the station) or when beyond the reception range of the station selected.

When the aircraft heading agrees generally with the track selector, the track deviation bar (TB) shows the pilot the position relative to the track selected and indicates whether the radial is to the right or left. The TB needle has a 10° spread from centre to either side when receiving a VOR signal. Fig. 2-58 shows that an aircraft 5° off track would have the TB one-half of the way from centre to the outside edge. If the aircraft is 10° off track the needle swings completely to one side. Each dot on the navigation indicator represents 2° when the pilot is flying VOR.

3. **TRACK ARROW:** Each time a track is chosen on the selector, the area around the VOR station is divided into halves or envelopes (Fig. 2-59). It is helpful to think of the dividing line as a track arrow, which runs through the station and points in the

direction of the selected track. The TB shows the pilot in which of these two envelopes the aircraft is located. If the aircraft is flying along the track line, the TB needle is centred (Fig. 2-59). If the aircraft flies to the left of the track arrow (as in *position A*), the TB needle swings to the right. If the aircraft moves to the right of the track arrow, (*position B*), the TB needle swings to the left.

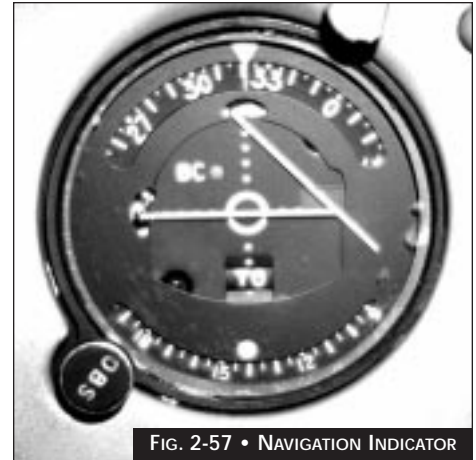

FIG. 2-57 • NAVIGATION INDICATOR

Whenever the pilot changes the track selector, he or she should visualize an imaginary track arrow over the station. In this way, the pilot can look at the TB and tell in which envelope the aircraft is located.

4. **REFERENCE LINE:** When the pilot selects a track, the position of another line is established, a reference line perpendicular to the track arrow and intersecting it at the station. The reference line divides the VOR reception area into two additional sectors. The area forward of the reference line is the FROM envelope and the area to the rear of the reference line is the TO envelope. The TO-FROM indicator shows in which envelope the aircraft is located. In Fig. 2-60 both aircraft display a FROM reading.

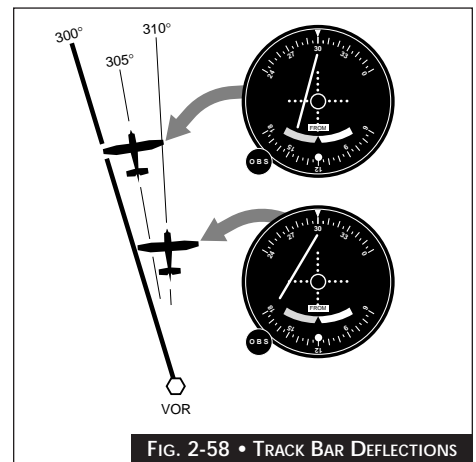

FIG. 2-58 • TRACK BAR DEFLECTIONS

Fig. 2-61 shows the readings that an aircraft would receive in eight different locations around the VOR station. In *position A*, the aircraft shows a centred TB, indicating that it is on track; the TO-FROM flag shows FROM. *Position B* shows a left TB and a FROM indication.

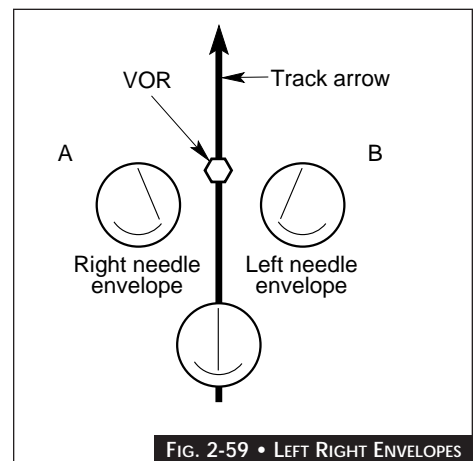

FIG. 2-59 • LEFT RIGHT ENVELOPES

Aircraft at *positions C and G* are in the *area of ambiguity*. In this area, the opposing reference signals that actuate the TO-FROM indicator cancel each other and produce an OFF Indication.

The area of ambiguity widens with increasing distance from the station. The greater the distance, the longer the TO-FROM flag will indicate OFF as the aircraft moves between the TO and FROM envelopes.

D. DETERMINATION OF POSITION

1. **HEADING:** Aircraft heading has absolutely no effect on the readings of the VOR indicator. No matter which direction the aircraft is heading, the pilot receives the same indication as long as the aircraft remains in the same track envelope (Fig. 2-62).
2. **POSITION FIX:** To determine a fix (without DME), the pilot must use two VOR stations because the VOR gives only direction and not distance from the station. First, the pilot should tune the number one VOR to one of the desired stations and make positive identification. Unless the pilot makes positive identification, that station should not be used. If a VOR station is shut down for maintenance or the signal is unreliable because of a malfunction, the navaid identification is not transmitted.

After identifying the station, the pilot should centre the TB needle with the positive FROM indication on the TO-FROM/OFF flag.

The pilot repeats this procedure with the other VOR station. Then, using the chart, the pilot draws a line outbound from the VORs along the radials indicated by the track selector. The intersection of these bearings is the aircraft's position (Fig. 2-63).

E. FLIGHT TO A VOR STATION

1. **BRACKETING:** Because there is generally a crosswind, the pilot rarely can intercept a radial, take up the heading of that track, and fly directly to the station. To stay on

track, the pilot must make a series of small corrections. The process of intercepting a radial and making the corrections necessary to remain on track is called bracketing. The method described here minimizes the number of turns needed to determine the necessary wind correction, and requires the least attention by the pilot.

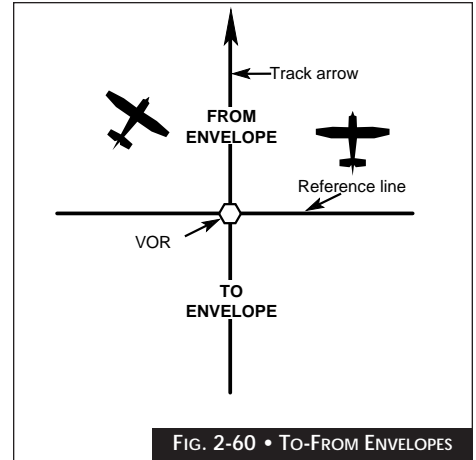

FIG. 2-60 • TO-FROM ENVELOPES

Fig. 2-64 shows the series of manoeuvres that a pilot uses in bracketing a radial to a VOR station. The pilot of the aircraft in *position 1* determines that the radial of the desired VOR station is to the right and the pilot must turn right to intercept it. In *position 2*, the pilot turns to an intercept angle of 30°. Since the radial is 090° to the station, the intercept heading is 120° as shown on the heading indicator.

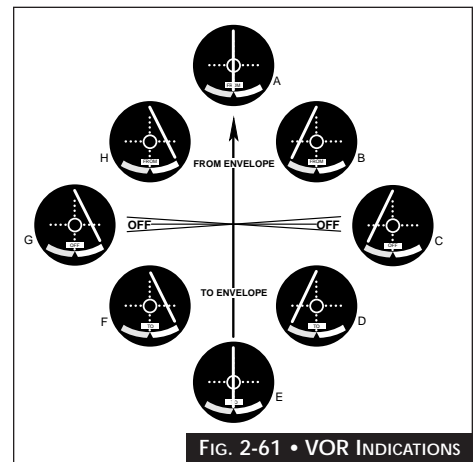

FIG. 2-61 • VOR INDICATIONS

In *position 3*, the aircraft intercepts the radial. The pilot immediately turns the aircraft to a 090° heading to coincide with the inbound direction of the radial. While using the heading indicator to carefully hold the heading, the pilot in *position 4* starts to drift off track. The pilot then takes up a new intercept heading of 070°, a 20° intercept angle. The pilot flies this new intercept heading of 070° until re-intercepting the radial, at which time

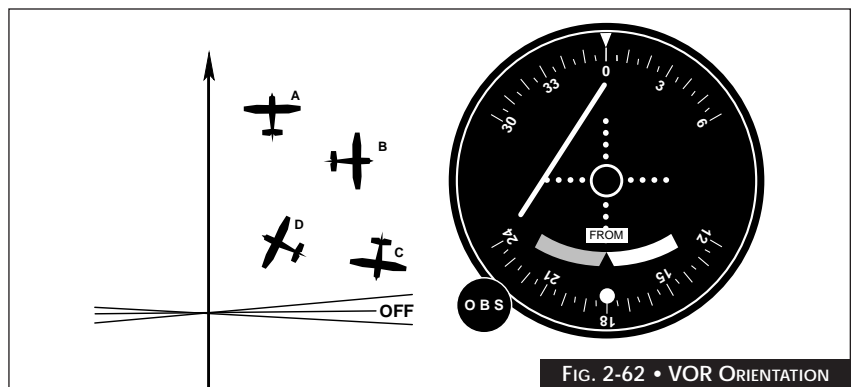

FIG. 2-62 • VOR ORIENTATION

(*position 7*) he or she divides this intercept angle by two and then turns to the new heading which is 080°.

The new heading of 080° lets the aircraft drift a little north of track. This informs the pilot that the desired track heading must be somewhere between 090°, which allows the aircraft to drift south of the radial, and 080°, which takes the aircraft north of the radial. At no time from this point to the station will the pilot turn to a heading less than 080° or heading more than 090°.

As shown in *position 9*, the aircraft takes up the heading of 090°, which allows the aircraft to drift back onto the radial. As the aircraft intercepts the radial at *position 10*, the pilot turns to a heading between 090° and 080°, then proceeds to the station, tracking the radial with an aircraft heading of 085°.

If the pilot takes up a specific intercept angle and then divides the angle by two, as necessary, the aircraft brackets the radial with the least number of turns and holds the track with the greatest accuracy.

2. **TRACK TO THE STATION:** The pilot should check the heading indicator against the magnetic compass when beginning to track. (The VOR indicator tells the pilot only the position of the aircraft relative to a certain radial and the pilot must rely upon the heading indicator for aircraft heading information).

The most common use of VOR navigation is to fly on a radial from station to station. The pilot selects a radial course on the OBS and tracks that radial by keeping the TB needle centred, which occurs as long as the OBS is in general agreement with the heading indicator. For example, if the radial is to the right, the indicator will point to the right, and the pilot must turn in this direction to intercept the radial.

As the aircraft passes the VOR station, the pilot receives two basic indications provided that the aircraft crosses directly over the station. The most positive indication is that the TO-FROM indicator changes to the

opposite reading. (TO to FROM). The second, less certain indication is the fluctuation of the TB. If the aircraft passes directly over the station, the needle fluctuates from side to side and returns to its original position. If the aircraft is left of track, the needle does not fluctuate, but continues to point to the right. Likewise, if the aircraft is right of track, the needle will point to the left and not fluctuate as the aircraft passes abeam the station.

3. **TIME CHECK:** Another use for VOR is to take a time check, which informs the pilot of the time remaining to fly to a station. For example, while inbound to the station on the 022° radial (Fig. 2-65), the pilot wishes to estimate the time to the station. The pilot elects to use the 030° radial to begin the time check, and turns the aircraft to a heading of 120°, which is at right angles to the 030° radial. The OBS is turned to 030° and as the needle centres, the pilot notes the time. Immediately afterward, the pilot rotates the OBS to 040°, which is the next radial to be used in the time check. The pilot then continues to hold the 120° aircraft heading and flies to the 040° radial. As the pilot crosses this radial and the needle centres, he or she notes the time and finds that it has taken two minutes (120 seconds) to make the 10° radial change.

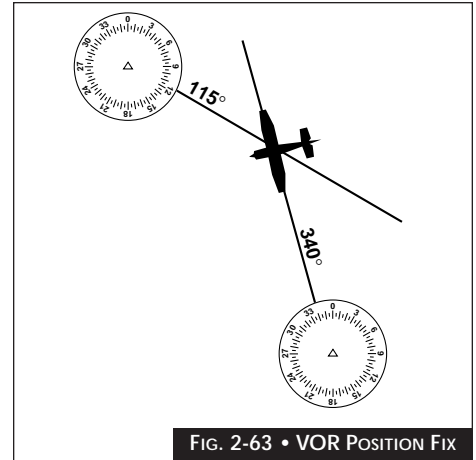

FIG. 2-63 • VOR POSITION FIX

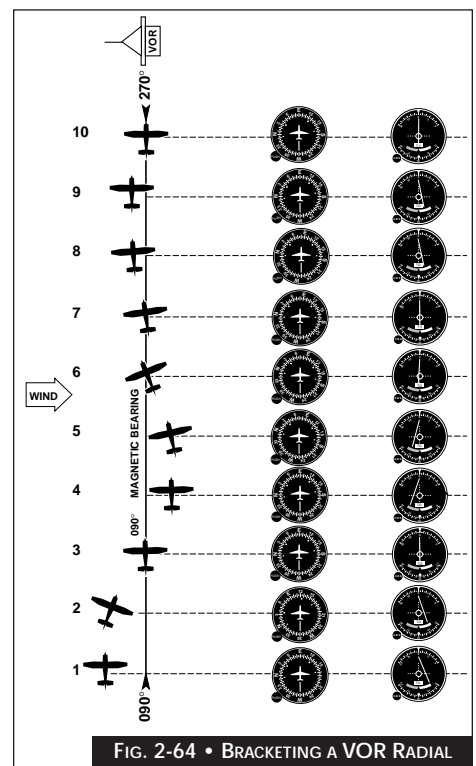

FIG. 2-64 • BRACKETING A VOR RADIAL

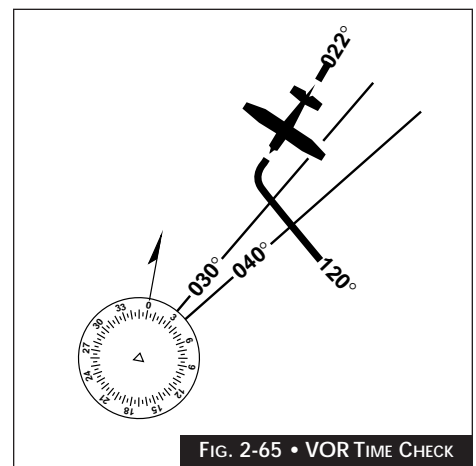

FIG. 2-65 • VOR TIME CHECK

The formula for determining the time remaining to the station is:

$$\frac{\text{TIME IN SECONDS BETWEEN RADIAL CHANGE}}{\text{DEGREES OF RADIAL CHANGE}} = \text{TIME TO STATION IN MINUTES}$$

Therefore, by dividing 120 seconds by 10, the pilot finds that there are 12 minutes remaining to fly to the station. Although this problem can be worked out using any degree of radial change, 10° of change is the simplest and fastest to compute.

2.2.4 DISTANCE MEASURING EQUIPMENT

A. GENERAL

Distance measuring equipment (DME), used by many pilots because of its convenience during flight, consists of airborne and ground equipment usually co-located. The DME provides distance (and in some systems groundspeed) information only from the ground facility. DME(P) is precision DME used in conjunction with MLS.

DME operates in the UHF frequency band however its frequency can be “paired” with VOR or ILS or localizer (LOC) frequencies. The receiving equipment in most aircraft provide for automatic DME selection through a coupled VOR/ILS receiver. Selection of the appropriate VOR or ILS frequency automatically tunes the DME.

DME information can also be received from a TACAN station by tuning in the “paired” frequency. This VHF frequency will be found in the navigation data box for the ground facility listed on the en route IFR chart.

The DME operates in the ultra-high frequency (UHF) band and therefore is restricted to line-of-sight transmission. With adequate altitude, the pilot can receive en route DME signals at distances over 200 NM, with an error of ±0.25 NM or 1.25% of the distance, whichever is greater. Approach DMEs paired with an ILS or LOC have a nominal range of about 40 NM.

B. BASIC PRINCIPLES

The DME operates by transmitting to and receiving paired pulses from the ground station. The transmitter in the aircraft sends out very narrow pulses at a frequency of about 1,000 MHz. These signals are received at the ground station and trigger a second transmission on a different frequency. These reply pulses are sensed by timing circuits in the aircraft’s receiver that measure the elapsed time between transmission and reception. Electronic circuits within the radio convert this measurement to electrical signals that operate the distance and ground speed indicators.



FIG. 2-66 • DIGITAL DME

C. DME COMPONENTS AND OPERATIONS

The transceiver (Fig. 2-66) that sends out the interrogating signal to the ground station contains an internal computer to measure the time interval that elapses until the response. The antenna, used for both transmission and reception, is a very small “sharks fin” normally mounted on the underside of the aircraft. Modern DME controls incorporate digital readouts of frequency, DME and groundspeed information.

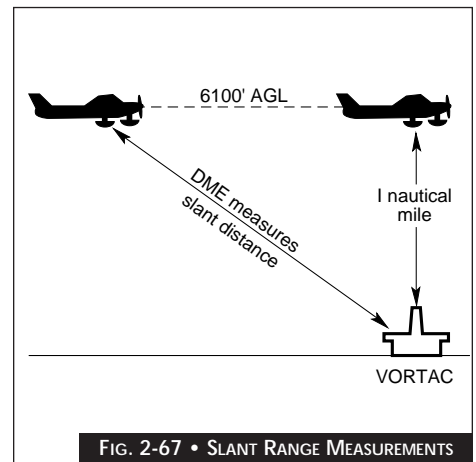

FIG. 2-67 • SLANT RANGE MEASUREMENTS

The DME displays information in the form of distance to the station and the aircraft’s groundspeed. Most DME radios exhibit this data on the face of the radio. The distance to the station is a *slant range*, expressed in nautical miles. For example, if an aircraft were directly over the DME station at 6,100 ft AGL, the distance indicator would read one mile (Fig. 2-67).

The DME receiver can express *groundspeed* in knots. This value is accurate only if the aircraft is flying directly to or from the station, because the DME measures groundspeed by comparing the time lapse between a series of pulses. When accurate, the groundspeed information allows

the pilot to make accurate estimates of time of arrival and accurate checks of aircraft progress.

When the pilot turns the function control knob of the DME receiver to “groundspeed”, there is not an immediate readout because the DME must be on the groundspeed function long enough to compare the time lapse between several pulse signals.

Certain DME radios have a *frequency-hold function*. These radios are channelled by the primary VHF navigation radio. When the pilot selects the VOR frequency, the DME also channels. The DME hold function retains the frequency of the original VORTAC station on the DME while the pilot channels the VOR receiver to another frequency.

A pilot with DME may pinpoint aircraft position using the radial of a VORTAC and the distance information from the same VORTAC; whereas a pilot without DME must use radials from two stations to get a position fix. The pilot also can use DME to establish intersections and holding patterns. When so equipped and cleared by ATC, pilots can establish holding patterns by reference to radials and DME. Refer to Article 4.4.8.

Many airports have instrument approach procedures based on use of VOR and DME equipment. Normally, an aircraft making this type of approach has lower minimums than when only the VOR is used.

D. FLYING A DME ARC

1. *CALM CONDITIONS:* Theoretically, with no wind, a 20° turn every 20° of arc will keep the aircraft close to the desired arc (Fig. 2-68). Although a DME arc may be flown using a standard VOR navigation indicator for bearing information, pilot orientation and turning points are simplified by using an RMI.

The pilot can fly the arc most easily by allowing the tail of the RMI needle to move 10° ahead of the wingtip position. The subsequent 20° turn places the tail of the needle 10° behind the wingtip position. The pilot holds this heading until the tail of the needle moves to 10° ahead of the wingtip, and so on. (Arcs are never less

than 7 NM DME or more than 30 NM DME). Depending on the distance to the VOR/DME, the aircraft will drift inside of and then beyond the desired arc. The pilot should attempt to keep the aircraft within plus or minus 0.5 NM of the arc. The obstacle clearance area associated with a DME arc is ±4 NM.

Fig. 2-69 shows one way of staying on the arc.

STEP 1

- a/ Northbound crossing R-090-RMI: tail reads 090 (on wingtip).
- b/ Maintain heading 000°M.
- c/ In no-wind conditions DME distance will increase, and the RMI needle will move off the wingtip position.

STEP 2

- a/ DME reads 20 NM plus.
- b/ RMI tail reads 080 or 10° ahead of wingtip.
- c/ Turn 20° left to 340.
- d/ RMI moves to 10° behind wingtip.

STEP 3

- a/ Steering 340°M in no-wind conditions: DME reading will reduce.
- b/ DME reading may reduce to less than 20 NM but do not worry unless it reduces to below 19.5 DME.
- c/ Maintain heading and allow DME to increase to 20 NM plus the tail of the RMI needle moves 10° ahead of the wingtip.

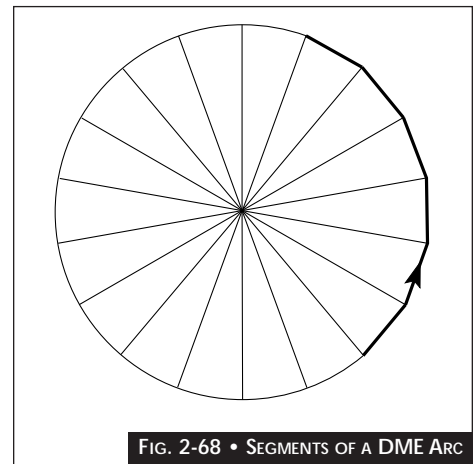

FIG. 2-68 • SEGMENTS OF A DME ARC

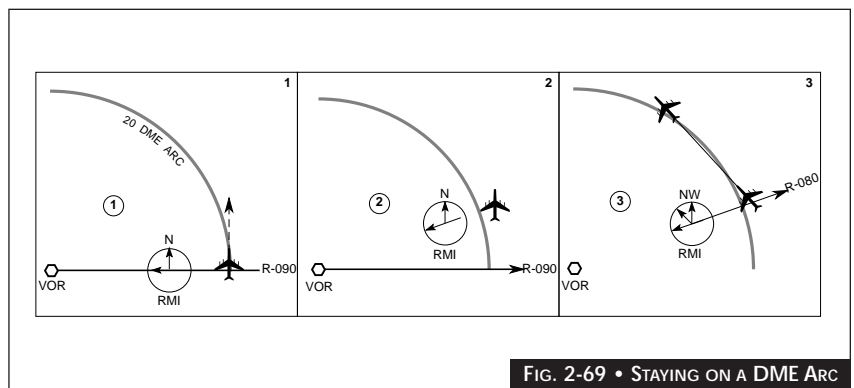

FIG. 2-69 • STAYING ON A DME ARC

d/ Turn 20° left and repeat the above steps.

2. **WIND DRIFT:** When flying in a wind pilots require practice before they can modify the procedure above to keep the aircraft close to the arc. Unlike drift correction on a straight track, the drift changes as the aircraft proceeds around the arc. The pilot should estimate the new heading, make a positive turn and hold the heading until the DME and RMI readouts show that it is time to turn again.

3. **ARCING TO A FINAL APPROACH:**

Example:

20 NM DME Arc (Fig. 2-70)

a/ At about 22 DME begin a 90° turn to the right to roll out on the 20 DME arc. A rule of thumb that may be used for calculating the lead point for the turn from a radial onto an arc is to use 0.5% of groundspeed for a standard rate turn and 1% of groundspeed for a 1/2 standard rate turn. In this example, a ground speed of 200 knots and a 1/2 rate turn was used ($200 \text{ kts} \times 1.0\% = 2 \text{ N.M.}$).

b/ Fly the arc not below the published MEA (in this case 3,000').

c/ On reaching the lead radial (LR 010), the aircraft is 2 NM from the final approach radial (000°R). Begin a left-hand turn of approximately 90° to intercept the desired radial.

d/ The pilot may now descend to the next altitude published on the profile view of the instrument procedure chart.

used as a means of identifying positions, receiving low and medium frequency voice communications, homing, tracking, and for navigation on instrument approach procedures.

The low/medium frequency navigation stations used by ADF include non-directional beacons, ILS radio beacon locators, and commercial broadcast stations. Because commercial broadcast stations normally are not used in navigation, this section will deal only with the non-directional beacon and ILS radio beacon.

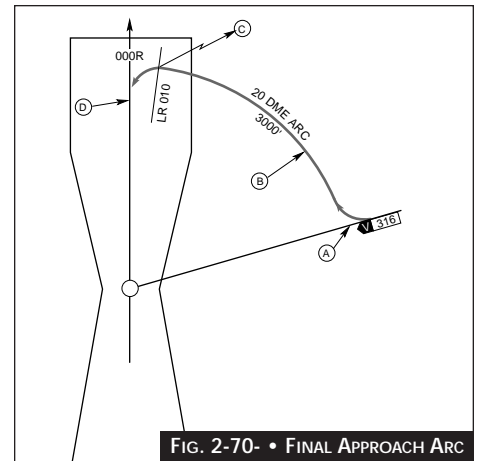

FIG. 2-70 • FINAL APPROACH ARC

A *non-directional radio beacon* (NDB) is classed according to its power output and usage:

- 1/ the L radio beacon has a power of less than 50W;
- 2/ the M classification of radio beacon has a power of 50 watts up to 2,000 W;
- 3/ the H radio beacon has a power output of 2,000 W or more;
- 4/ the ILS radio beacon is a beacon which is placed at the same position as the outer marker of an ILS system (or replaces the OM).



FIG. 2-71 • NDB CONTROL PANELS

2.2.5

ADF - AUTOMATIC DIRECTION FINDER SYSTEM

A. **DESCRIPTION**

One of the older types of radio navigation is the automatic direction finder (ADF) or *non-directional beacon (NDB)*. The ADF receiver, a "backup" system for the VHF equipment, can be used when line-of-sight transmission becomes unreliable or when there is no VOR equipment on the ground or in the aircraft. It is

B. **LIMITATIONS AND BENEFITS**

Pilots using ADF should be aware of the following limitations:

Radio waves reflected by the ionosphere return to the earth 30 to 60 miles from the station and may cause the ADF pointer to fluctuate. The twilight effect is most pronounced during the period just before and after sunrise/sunset. Generally, the greater the distance from the station the greater the effect. The effect can be minimized by averaging the fluctuation, by flying at a higher altitude, or by selecting a station with a lower frequency (NDB

transmissions on frequencies lower than 350 KHz have very little twilight effect).

Mountains or cliffs can reflect radio waves, producing a terrain effect. Furthermore, some of these slopes may have magnetic deposits that cause indefinite indications. Pilots flying near mountains should use only strong stations that give definite directional indications, and should not use stations obstructed by mountains.

Shorelines can refract or bend low frequency radio waves as they pass from land to water. Pilots flying over water should not use an NDB signal that crosses over the shoreline to the aircraft at an angle less than 30°. The shoreline has little or no effect on radio waves reaching the aircraft at angles greater than 30°.

When an *electrical storm* is nearby, the ADF needle points to the source of lightning rather than to the selected station because the lightning sends out radio waves. The pilot should note the flashes and not use the indications caused by them.

The ADF is subject to errors when the aircraft is banked. *Bank error* is present in all turns because the loop antenna which rotates to sense the direction of the incoming signal is mounted so that its axis is parallel to the normal axis of the aircraft. Bank error is a significant factor during NDB approaches.

While the ADF has drawbacks in special situations, the system does have some general advantages. Two of these benefits are the low cost of installation of NDBs and their relatively low degree of maintenance. Because of this, NDBs provide homing and navigational facilities in terminal areas and en route navigation on low-level airways and air routes without VOR coverage. Through the installation of NDBs many smaller airports are able to provide an instrument approach that otherwise would not be economically feasible.

The NDBs transmit in the frequency band of 200 to 415 KHz. The signal is *not* transmitted in a line of sight as VHF or UHF, but rather follows the curvature of the earth; this permits reception at low altitudes over great distances. The ADF is used for primary navigation over long distances in remote areas of Canada.

C. *ADF COMPONENTS*

Fig. 2-71 shows the major ADF components except the receiving antenna, which on most light aircraft is a length of wire running from an insulator on the cabin to the vertical stabilizer.

1. *RECEIVER*: Controls on the ADF receiver permit the pilot to tune the station desired and to select the mode of operation. When tuning the receiver the pilot must positively identify the station. The low or medium frequency radio beacons transmit a signal with 1,020 Hz modulation keyed to provide continuous identification except during voice communications. All air facilities radio beacons transmit a continuous two- or three-unit identification in Morse code, except for ILS front course radio beacons which normally transmit a continuous one letter identifier in Morse code. The signal is received, amplified, and converted to audible voice or Morse code transmission. The signal also powers the bearing indicator.

Tuning the ADF: To tune the ADF receiver, the pilot should follow these steps:

- a/ turn the function knob to the RECEIVE mode. This turns the set on and selects the mode that provides the best reception. Use the RECEIVE mode for tuning the ADF and for continuous listening when the ADF function is not required;
- b/ select the desired frequency band and adjust the volume until background noise is heard;
- c/ with the tuning controls, tune the desired frequency and then re-adjust volume for best listening level and identify the station;
- d/ to operate the radio as an automatic direction finder, switch the function knob to ADF; and
- e/ the pointer on the bearing indicator shows the bearing to the station in relation to the nose of the aircraft. A loop switch aids in checking the indicator for proper operation. Close the switch. The pointer should move

away from the bearing of the selected station. Then release the switch; the pointer should return promptly to the bearing of the selected station. A sluggish return or no return indicates malfunctioning of the equipment or a signal too weak to use.

2. **CONTROL BOX - DIGITAL READOUT TYPE:** Most modern aircraft have this type of control in the cockpit. In this equipment the frequency tuned is displayed as a digital readout of numbers rather than tuning a frequency band.

a/ **Function Selector (Mode Control).** Allows selection of OFF, ADF, ANT or TEST Position.

ADF - Automatically determines bearing to selected station and displays it on the RMI. Uses sense and loop antennae.

ANT - Reception of Radio signals using the sense antenna. Recommended for tuning.

TEST - Performs ADF system self-test. RMI needle moves to 315°.

b/ **Frequency Selector Switches.** Three concentric knobs, permit selection of operating frequency. Two frequencies can be preselected. Only one can be used at a time. The transfer switch indicates the frequency in use.

c/ **Selected Frequency Indicators.** Provides a visual read-out of the frequencies selected. The numbers can be printed on drums that rotate vertically or, in more modern sets, they are displayed by light emitting diodes.

3. **ANTENNAE:** The ADF receives signals on both loop and sense antennae. The loop antenna in common use today is a small flat antenna without moving parts. Within the antenna are several coils spaced at various angles. The loop antenna senses the direction of the station by the strength of the signal on each coil but cannot determine whether the bearing is TO or FROM the station. The sense antenna

provides this latter information, and also voice reception when the ADF function is not required.

4. **BEARING INDICATOR:** As mentioned above, the bearing indicator (Fig. 2-72) displays the bearing to the station relative to the nose of the aircraft. If the pilot is flying directly to the station, the bearing indicator points to 0°. An ADF with a fixed card bearing indicator always represents the nose of the aircraft as 0° and the tail as 180°.



FIG. 2-72 • FIXED CARD BEARING INDICATOR

Relative bearing (Fig. 2-73) is the angle formed by the intersection of a line drawn through the centerline of the aircraft and a line drawn from the aircraft to the radio station. This angle is always measured clockwise from the nose of the aircraft and is indicated directly by the pointer on the bearing indicator.

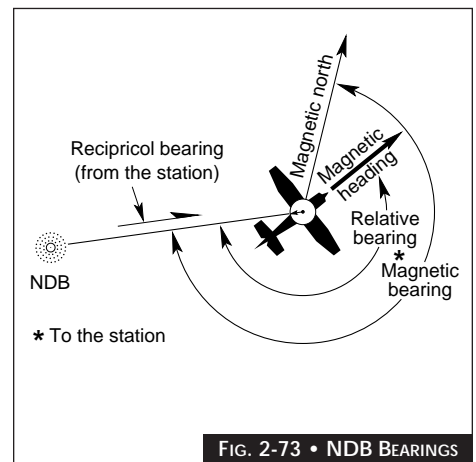

FIG. 2-73 • NDB BEARINGS

Magnetic bearing (Fig. 2-73) is the angle formed by the intersection of a line drawn from the aircraft to the radio station and a line drawn from the aircraft to magnetic north. The pilot calculates the magnetic bearing by adding the relative bearing shown on the indicator to the magnetic heading of the aircraft. For example, if the magnetic heading of the aircraft is 40° and the relative bearing 210°, the magnetic bearing to the station is 250°. Reciprocal bearing is the opposite of the magnetic bearing, obtained by adding or subtracting 180° from the magnetic bearing. The pilot calculates it when tracking outbound and when plotting fixes.

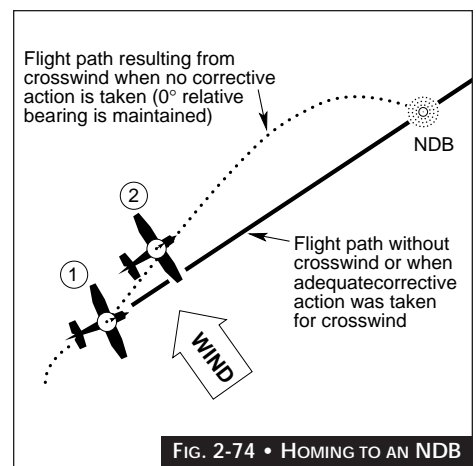

FIG. 2-74 • HOMING TO AN NDB

D. ADF OPERATIONS

1. **MONITORING:** Since the ADF receiver normally has no system failure or “OFF” warning flags to provide the pilot with immediate indication of a beacon failure or receiver failure, the ADF audio must be monitored. *The “idents” should be monitored anytime the ADF is used as a sole means of en route navigation. During the critical phases of approach, missed approach and holding, at least one pilot or flight crew member shall aurally monitor the beacon “idents” unless the aircraft instruments automatically advise the pilots of ADF or receiver failure.*

2. **HOMING:** One of the most common ADF uses is “*homing to a station*”. When using this procedure, the pilot flies to a station by keeping the bearing indicator needle on 0° when using a fixed-card ADF (Fig. 2-74). The pilot should follow these steps:
 - a/ tune the desired frequency and identify the station. Set the function selector knob to ADF and note the relative bearing;
 - b/ turn the aircraft toward the relative bearing until the bearing indicator pointer is 0°; and
 - c/ continue flight to the station by maintaining a relative bearing of 0°.

Fig. 2-74 shows that if the pilot must change the magnetic heading to hold the aircraft on 0° the aircraft is drifting due to a crosswind. If the pilot does not make crosswind corrections, the aircraft flies a curved path to the station while the bearing indicator pointer remains at zero. The aircraft in *position 2* must keep changing its heading to maintain the 0° relative bearing while flying to the station.

The bracketing method used here is basically the same as that explained in Article 2.2.3 E (1). The major difference is that bracketing a VOR requires the pilot to bracket a radial identified by the TB needle, whereas bracketing an ADF magnetic bearing requires the pilot to identify it by using both the bearing indicator and the heading indicator.

Assume the pilot of the aircraft in *position 1* (Fig. 2-75) desires to intercept the 090° magnetic bearing to the non-directional beacon. The pilot then sets up an intercept angle of 30° which is shown by the 120° heading of the aircraft. The ADF pointer indicates 340°. Because the magnetic bearing equals the magnetic heading of the aircraft and the relative bearing, the pilot adds 120° (the relative bearing) and finds that the aircraft is on the 100° magnetic bearing.

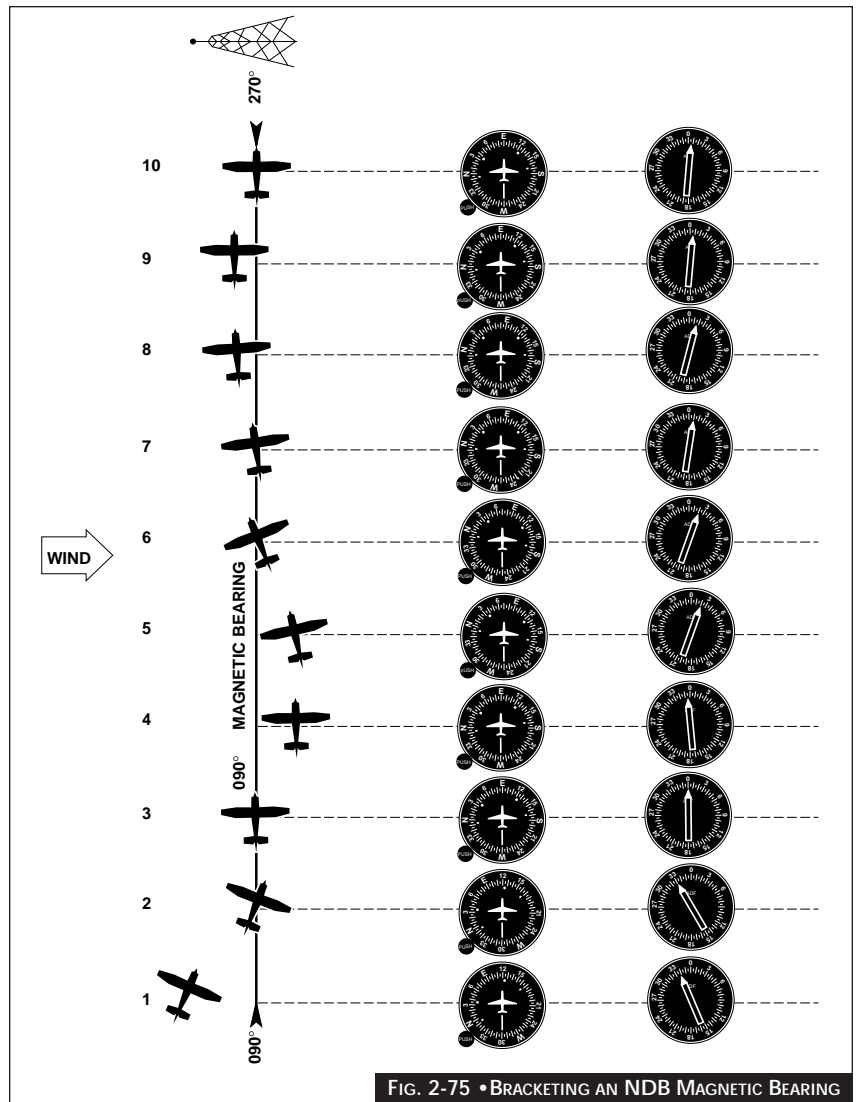

FIG. 2-75 • BRACKETING AN NDB MAGNETIC BEARING

NOTE:

Whenever the aircraft heading and relative bearing equal more than 360° the pilot should subtract 360° from the resulting figure. The pilot then follows the rest of the bracketing procedure.

3. **TRACKING FROM A STATION:** A pilot can use ADF to track from a station by employing the principles of bracketing a magnetic bearing. Fig. 2-76 illustrates an aircraft tracking outbound from a station with a crosswind from the north. The reciprocal bearing is 090°, and the pilot tracks this bearing by flying the aircraft with 10° of wind correction. The pilot knows that the aircraft is tracking a reciprocal bearing because the heading indicator (080°) and relative bearing (190°) equal the magnetic bearing (270°).

4. **POSITION FIX BY ADF:** The ADF receiver can help the pilot to make a definite position fix by using two or more stations and the process of triangulation. To determine the exact location of the aircraft, the pilot should use these procedures:

- a/ locate two stations in the vicinity of the aircraft. Tune and identify each;
- b/ set the function selector knob to ADF, then note the magnetic heading of the aircraft as read on the heading of the aircraft as read on the heading indicator. Continue to fly this heading and tune in the stations previously identified, recording the relative bearing for each station;
- c/ add the relative bearing of each station to the magnetic heading to obtain the magnetic bearing. Correct the magnetic bearing for east-west variation to obtain the true bearing; and
- d/ plot the reciprocal for each true bearing on the chart. The aircraft is located at the intersection of the bearing lines (Fig. 2-77).

5. **TIME COMPUTATION TO FLY TO A STATION:** Computing time to the station is basically the same for ADF as it is for VOR (refer to Article 2.2.3. E (2)) therefore, a brief example is sufficient here. The basic procedure is to:

- a/ turn the aircraft until the ADF pointer is either at 090° or 270° and note the time; and
- b/ fly a constant magnetic heading until the ADF pointer indicates a bearing change of 10°. Note the time again and apply the following formula:

$$\frac{\text{TIME IN SECONDS BETWEEN BEARING CHANGE}}{\text{DEGREES OF BEARING CHANGE}} = \text{TIME TO STATION IN MINUTES}$$

For example, if it takes 45 sec to fly a bearing change of 10°, the aircraft is:

$$45 / 10 = 4.5 \text{ min from the station}$$

To find distance to a station multiply time by distance covered in one minute using TAS or preferably G/S.

As with VOR procedures, a 10° bearing change is the simplest and easiest to use in making this calculation. If the pointer moves so rapidly that a satisfactory time check cannot be obtained during a 10° bearing change, this rapid movement indicates that the aircraft is very close to the station.

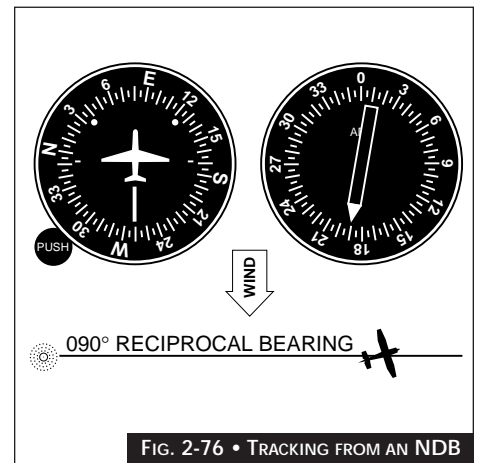

2.2.6 RADIO MAGNETIC INDICATOR

Many radio magnetic indicator (RMI) systems are designed for use with either an ADF or VOR station by selecting with a switch either VOR or ADF. (Fig. 2-79)

The radio magnetic indicator (RMI) is both a bearing indicator and a heading indicator (Fig. 2-78). The heading indicator uses a

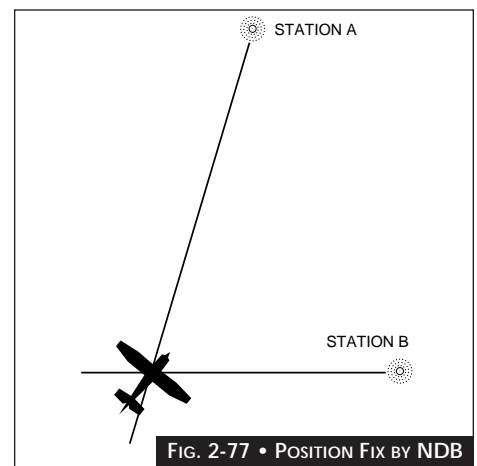

“slaved gyro”, i.e., the heading indicator is connected to a remotely located magnetic compass and is automatically “fed” directional signals. The heading indicator always shows the direction of the aircraft in relation to magnetic north.

Therefore, the pointer of the bearing indicator always displays the actual magnetic bearing to the non-directional beacon. The tail of the pointer indicates the reciprocal bearing. This system lessens the pilot’s task and further minimizes the possibility of errors.

The RMI further simplifies tracking to a station because the pilot needs to refer to only one instrument instead of two. The pilot determines the magnetic heading by looking at the heading indicated on the azimuth card, and the magnetic bearing shown by the pointer. The aircraft heading used to compensate for wind drift does not influence the magnetic bearing as long as the aircraft remains on the bearing. As shown in Fig. 2-80, the pilot flying eastbound on the 095° magnetic bearing with 10° of north wind correction sees a display on the RMI of 085° magnetic heading (aircraft heading) and 095° magnetic bearing (to the station).

2.2.7
THE INSTRUMENT LANDING SYSTEM

A. GENERAL DESCRIPTION

Instrument landing system (ILS) facilities are a highly accurate and dependable means of navigating to the runway in IFR conditions. When using the ILS, the pilot determines aircraft position primarily by reference to instruments. The ILS consists of:

- i/ the localizer transmitter;
- ii/ the glide path transmitter;
- iii/ the outer marker (can be replaced by an NDB or other fix);
- iv/ the approach lighting system.

ILS is classified by category in accordance with the capabilities of the ground equipment. *Category I ILS* provides guidance information down to a decision height (DH) of not less than 200 ft. Improved equipment (airborne and ground) provide for *Category II ILS* approaches.

A DH of not less than 100 ft. on the radar altimeter is authorized for Category II ILS approaches.

The ILS provides the lateral and vertical guidance necessary to fly a precision approach, where glide slope information is provided. A precision approach is an approved descent procedure using a navigation facility aligned with a runway where glide slope information is given. When all components of the ILS system are available, including the approved approach procedure, the pilot may execute a precision approach.



FIG. 2-78 • RADIO MAGNETIC INDICATOR

B. LOCALIZER

1. *GROUND EQUIPMENT:* The primary component of the ILS is the localizer, which provides lateral guidance. The localizer is a VHF radio transmitter and antenna system using the same general range as VOR transmitters (between 108.10 MHz and 111.95 MHz). Localizer frequencies, however, are only on odd-tenths, with 50 KHz spacing between each frequency. The transmitter and antenna are on the centerline at the opposite end of the runway from the approach threshold.



FIG. 2-79 • RMI WITH VOR AND NDB INPUTS

The localizer *back course* is used on some, but not all, ILS systems. Where the back course is approved for landing purposes, it is generally provided with a 75 MHz back marker facility or NDB located 3 to 5 NM from touchdown. The course is checked periodically to ensure that it is positioned within specified tolerances.

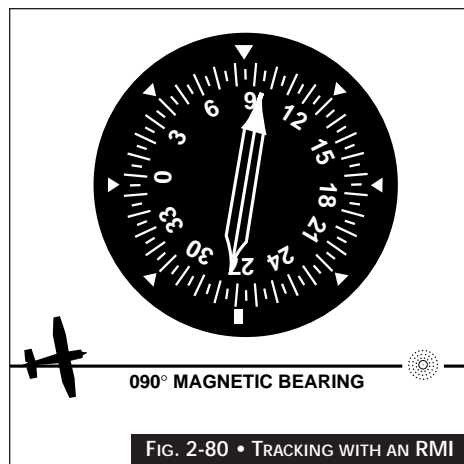

FIG. 2-80 • TRACKING WITH AN RMI

2. **SIGNAL TRANSMISSION:** The signal transmitted by the localizer consists of two vertical fan-shaped patterns that overlap at the centre (Fig. 2-81). They are aligned with the extended centerline of the runway. The right side of this pattern, as seen by an approaching aircraft, is modulated at 150 Hz and is called the “blue” area. The left side of the pattern is modulated at 90 Hz and is called the “yellow” area. The overlap between the two areas provides the on-track signal.

The *width of the navigational beam* may be varied from approximately 3° to 6°, with 5° being normal. It is adjusted to provide a track signal approximately 700 ft wide at the runway threshold. The width of the beam increases so that at 10 NM from the transmitter, the beam is approximately one mile wide.

The *localizer is identified* by an audio signal superimposed on the navigational signal. The audio signal is a two-letter identification preceded by the letter “I”, e.g., “I-OW”.

The *reception range* of the localizer is at least 18 NM within 10° of the on-track signal. In the area from 10° to 35° of the on-track signal, the reception range is at least 10 NM (Fig. 2-82). This is because the primary strength of the signal is aligned with the runway centerline.

3. **LOCALIZER RECEIVER:** The localizer signal is received in the aircraft by a localizer receiver. The localizer receiver is combined with the VOR receiver in a single unit. The two receivers share some electronic circuits and also the same frequency selector, volume control, and ON-OFF control.

The localizer signal activates the vertical needle called the *track bar (TB)*. Assuming a final approach track aligned north and south (Fig. 2-81), an aircraft east of the extended centerline of the runway (*position 1*) is in the area modulated at 150 Hz. The TB is deflected to the left. Conversely, if the aircraft is in the area west of the runway centerline, the 90 Hz signal causes the TB to deflect to the right (*position 2*). In the overlap area, both signals apply a force to

the needle, causing a partial deflection in the direction of the strongest signal. Thus, if an aircraft is approximately on the approach track but slightly to the right, the TB is deflected slightly to the left. This indicates that a correction to the left is necessary to place the aircraft in precise alignment.

At the point where the 90 Hz and 150 Hz signals are of equal intensity, the TB is centred, indicating that the aircraft is located precisely on the approach track (*position 3*).

When the TB is used in conjunction with the VOR, fullscale needle deflection occurs

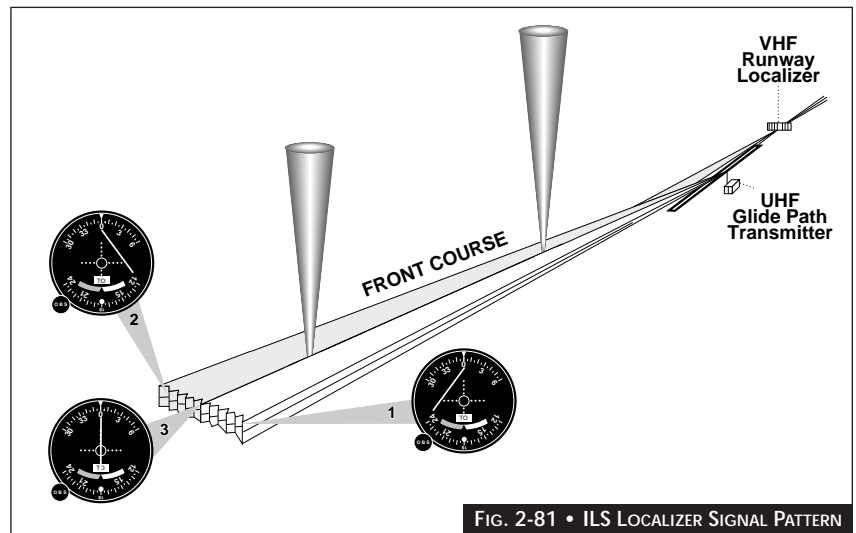

FIG. 2-81 • ILS LOCALIZER SIGNAL PATTERN

at 10° either side of the track shown on the track selector. When this same needle is used as an ILS localizer indicator, full-scale needle deflection occurs at approximately 2.5° from the centre of the localizer beam.

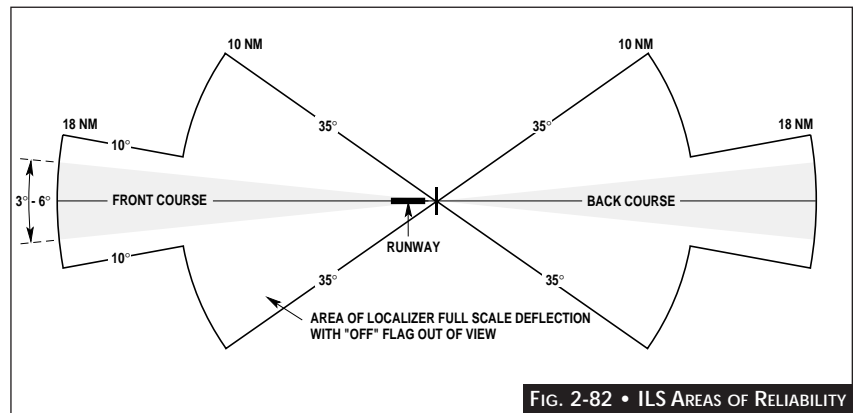

FIG. 2-82 • ILS AREAS OF RELIABILITY

Thus the sensitivity of the TB is approximately *four times greater* when used as a localizer indicator as opposed to VOR navigation.

In the localizer function, the TB does not depend on a correct track selector setting in most cases; however, the pilot should set the track selector for the approach track as a reminder of the final approach.

When an OFF flag appears in front of the vertical needle, it indicates that the signal is too weak, and, therefore, the needle indications are unreliable. A momentary OFF flag, or brief TB needle deflections, or both, may occur when obstructions or other aircraft pass between the transmitting antenna and the receiving aircraft.

C. GLIDE SLOPE EQUIPMENT

1. **TRANSMITTER:** The glide slope provides vertical guidance to the pilot during the approach. The ILS glide slope is produced by a ground-based UHF radio transmitter and antenna system, operating at a range of 329.30 MHz to 335.00 MHz, with a 50 kHz spacing between each channel. The transmitter is located 750 to 1,250 ft down the runway from the threshold, offset 400 to 600 ft from the runway centerline. Monitored to a tolerance of $\pm 1/2$ degree, the UHF glide path is "paired" with (and usually automatically tuned by selecting) a corresponding VHF localizer frequency.

Like the localizer, the glide slope signal consists of two overlapping beams modulated at 90 Hz and 150 Hz (Fig. 2-83). Unlike the localizer, however, these signals are aligned above each other and are radiated primarily along the approach track. The thickness of the overlap area is 1.4° or $.7^\circ$ above and $.7^\circ$ below the optimum glide slope.

This glide slope signal may be adjusted between 2° and 4.5° above a horizontal plane (Fig. 2-84). A typical adjustment is 2.5° to 3° , depending upon such factors as obstructions along the approach path and the runway slope.

False signals may be generated along the

glide slope in multiples of the glide path angle, the first being approximately 6° above horizontal. This false signal will be a reciprocal signal (i.e. the fly up and fly down commands will be reversed). The false signal at 9° will be oriented in the same manner as the true glide slope. There are no false signals below the actual slope. An aircraft flying according to the published approach procedure on a front course ILS should not encounter these false signals.

2. **SIGNAL RECEIVER:** The glide slope signal is received by a UHF receiver in the aircraft. In modern avionics installations, the controls for this radio are integrated with the VOR controls so that the proper glide slope frequency is tuned automatically when the localizer frequency is selected.

The glide slope signal activates the glide slope needle, located in conjunction with the TB (Fig. 2-83). There is a separate OFF flag in the navigation indicator for the glide slope needle. This flag appears when the glide slope signal is too weak. As happens with the localizer, the glide slope needle shows full deflection until the aircraft reaches the point of signal overlap. At this time, the needle shows a partial deflection in the direction of the strongest signal. When both signals are equal, the needle centres horizontally, indicating that the aircraft is precisely on the glide path.

The pilot may determine precise location with respect to the approach path by

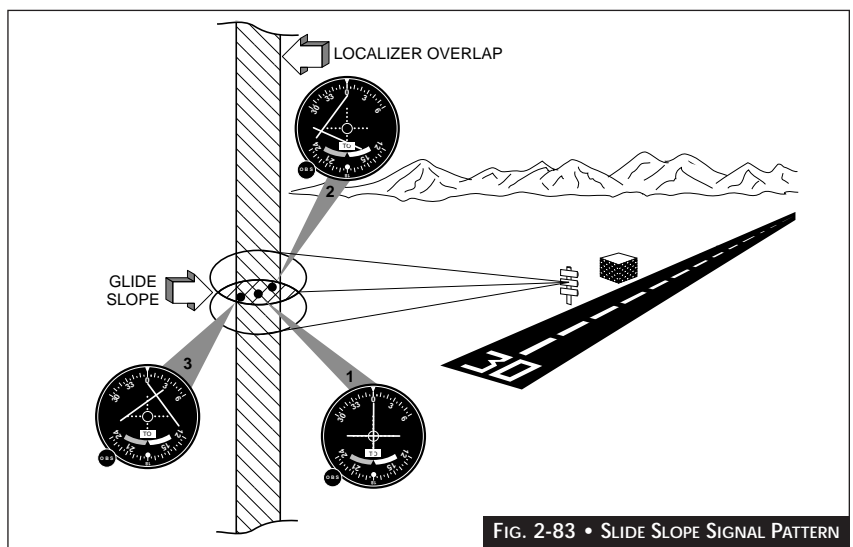

FIG. 2-83 • SLIDE SLOPE SIGNAL PATTERN

referring to a single instrument because the navigation indicator provides both vertical and lateral guidance. Fig. 2-83, position 1, shows both needles centred, indicating that the aircraft is located in the centre of the approach path. The indication at position 2 tells the pilot to fly down and left to correct the approach path. Position 3 shows the requirements to fly up and right to reach the proper path. With 1.4° of beam overlap, the area is approximately 1,500 ft thick at 10 NM, 150 ft at 1 NM, and less than one foot at touchdown.

The apparent sensitivity of the instrument increases as the aircraft nears the runway. The pilot must monitor it carefully to keep the needle centred. As said before, a full deflection of the needle indicates that the aircraft is either high or low but there is no indication of how high or low.

D. ILS MARKER BEACONS

- GENERAL:** Instrument landing system marker beacons provide information on distance from the runway by identifying predetermined points along the approach track. These beacons are low-power transmitters that operate at a frequency of 75 MHz with 3 W or less rated power output. They radiate an elliptical beam upward from the ground. At an altitude of 1,000 ft, the beam dimensions are 2,400 ft long and 4,200 ft wide. At higher altitudes, the dimensions increase significantly.
- OUTER MARKER (OM):** The outer marker (if installed) is located 3 1/2 to 6 NM from the threshold within 250 ft of the extended runway centerline. It intersects the glide slope vertically at approximately 1,400 ft above runway elevation. It also marks the approximate point at which aircraft normally intercept the glide slope, and designates the beginning of the final approach segment. The signal is modulated at 400 Hz, which is an audible low tone with continuous Morse code dashes at a rate of two dashes per second. The signal is received in the aircraft by a 75 MHz marker beacon receiver. The pilot hears a tone over the speaker or headset and sees a blue light that flashes in synchronization with the aural tone (Fig. 2-85). Where geographic

conditions prevent the positioning of an outer marker, a DME unit may be included as part of the ILS system to provide the pilot with the ability to make a positive position fix on the localizer. In most ILS installations, the OM is replaced by an NDB.

- MIDDLE MARKER (MM):** Middle markers have been removed from all ILS facilities in Canada but are still used in the United States. The middle marker is located approximately .5 to .8 NM from the threshold on the extended

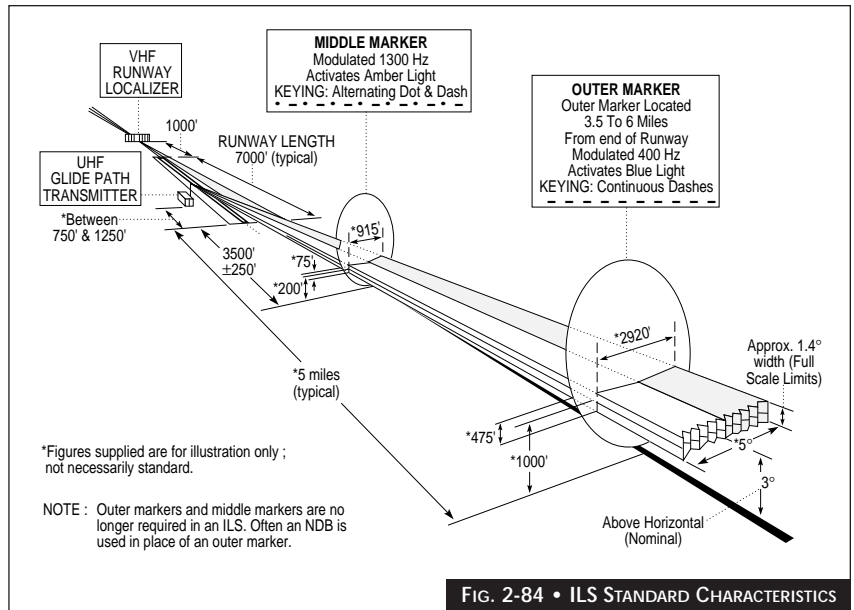

FIG. 2-84 • ILS STANDARD CHARACTERISTICS

runway centerline. The middle marker crosses the glide slope at approximately 200 to 250 ft above the runway elevation and is near the missed approach point for the ILS Category I approach.

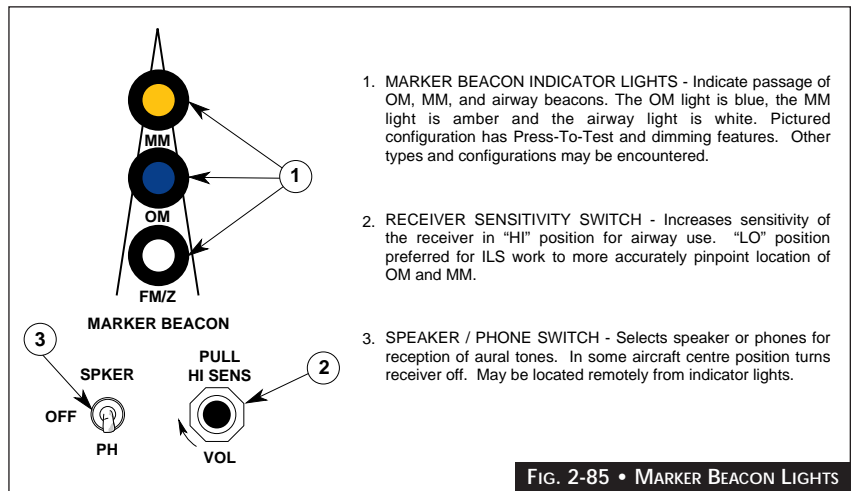

FIG. 2-85 • MARKER BEACON LIGHTS

4. **BACK MARKER (BM):** The back course marker (BM), if installed, is normally located on the localizer back course approximately four to six miles from the runway threshold. The BM low pitched tone (400 Hz) is heard as a series of dots. It illuminates the aircraft's *white* marker beacon light. An NDB or DME fix can also be used and in most locations replace the BM.

E. LIGHTING SYSTEMS

1. **GENERAL:** Various runway environment lighting systems serve as integral parts of the ILS system to aid the pilot in landing. Any or all of the following lighting systems may be provided at a given facility: approach light system (ALS), sequenced flashing light (SFL), touchdown zone lights (TDZ) and centerline lights (CLL-required for Cat II operations.) Further information on runway and approach lighting systems can be found in the *Canada Air Pilot*.
2. **RUNWAY VISIBILITY MEASUREMENT:** In order to land, the pilot must be able to see appropriate visual aids not later than the arrival at the decision height (DH) or the missed approach point (MAP).

Until fairly recently, the weather observer simply “peered into the murk”, trying to identify landmarks at known distances from the observation point. This method is rather inaccurate; therefore, instrumentation was developed to improve the observer’s capability.

The instrument designed to provide visibility information is called a *transmissometer*. It is normally located adjacent to a runway. The light source (Fig. 2-86) is separated from the photo-electric cell receiver by 500 to 700 ft. The receiver, connected to the instrument readout in the airport tower, senses the reduction in the light level between it and the light source caused by increasing amounts of particulate matter in the air. In this way the receiver measures the relative transparency or opacity of the air. The readout is calibrated in feet of visibility and is called runway visual range (RVR).

3. **RUNWAY VISUAL RANGE (RVR):** The RVR is the maximum distance in the direction of

take-off or landing at which the runway or the specified light or markers delineating it can be seen from a height corresponding to the average eye-level of pilots at touchdown.

Runway visual range readings usually are expressed in hundreds of feet. For example, “RVR 24” means that the visual range along the runway is 2,400 ft. In weather reports, RVR is reported in a code: R36/4000 FT/D; meaning RVR for Runway 36 is 4000 ft and decreasing. Because visibility may differ from one runway to another, the RVR value is always given for the runway where the equipment is located. At times, visibility may even vary at different points along the same runway due to a local condition such as a fog bank, smoke, or a line of precipitation. For this reason, additional equipment may be installed for the departure end and mid-point of a runway.

Runway visual range reports are intended to indicate how far the pilot can see along the runway in the touchdown zone; however, the *actual visibility at other points along the runway may differ* due to the siting of the transmissometer. The pilot should take this into account when making decisions based on reported RVR.

Runway visual range is not reported unless the prevailing visibility is less than two miles or the RVR is 6,000 ft or less. This is so because the equipment cannot measure RVR above 6,000 ft. When it is reported, RVR can be used as an aid to pilots in determining what to expect during the final

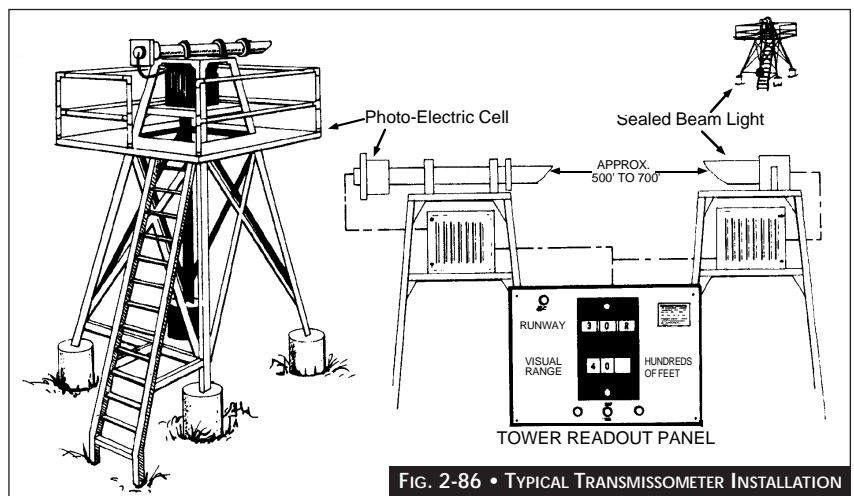

FIG. 2-86 • TYPICAL TRANSMISSOMETER INSTALLATION

stages of an instrument approach. Instrument approach charts state the advisory values of visibility and RVR. RVR is limiting only for the approach ban which restricts or bans approaches if the RVR is reading below 1200. See 4.5.7 (A) for further.

Runway visual range information is provided to the ATC arrival control sector, the PAR position, and the control tower or FSS. It is passed routinely to the pilot when conditions warrant. RVR information may be included in aviation weather reports.

Ground visibility will continue to be reported and used in the application of take-off and landing minima. At runways with a transmissometer and digital readout equipment or other suitable means, RVR is used in lieu of prevailing visibility in determining the visibility minima unless affected by a local weather phenomenon of short duration.

The normal RVR reading is based on a runway light setting of strength 3. If the light settings are increased to strength 4 or 5, it causes a relative increase in the RVR reading. No decrease in the RVR reading is evident for light settings of less than setting 3. Pilots shall be advised when the runway light setting is adjusted to 4 or 5. If the RVR for a runway is measured at two locations, the controller identifies the touchdown location as "Alfa" and the mid-runway location as "Bravo".

In all cases, the pilot can request a light setting suitable for his or her requirements. When more than one aircraft is conducting an approach, the pilot of the second aircraft may request a change in the light setting after the first aircraft has completed its landing.

Because of the complex equipment requirements, RVR usually is only available at more active airports and not necessarily for all runways. If RVR equipment is not available or temporarily out of service for a given runway, the pilot uses the observer method to provide visibility information. In this case, the visibility is expressed as miles or fractions of a mile. The

relationship between RVR values and visibility is shown below.

RVR (FEET)	VISIBILITY (STATUTE MILES)
1400	1/4
2600	1/2
4000	3/4
5000	1

NOTE:

These are designated values, not exact numerical equivalents.

F. NDBs AT MARKER BEACON SITES

Additional aids may be available to assist the pilot in reaching the final approach fix. One of these aids is the NDB which can be co-located with or replace the outer marker (OM) or back marker (BM). It is a low-frequency nondirectional beacon with a transmitting power of less than 25 W and a frequency range of 200 KHz to 415 KHz. The reception range of the radio beacon is at least 15 NM. In a number of cases an en route NDB is purposely located at the outer marker so that it may serve as a terminal as well as an en route facility.

As a general rule radio beacons carry one letter Morse code identifiers. When the radio beacon is located at the outer marker, the identifier is formed by eliminating the standard letter "I" and using the letter of the localizer identifier. For example on the ILS approach for runway 07 at Ottawa, the localizer identifier is IOW. The identifier for the radio beacon, which is located at the outer marker, is O.

2.2.8 MICROWAVE LANDING SYSTEM (MLS)

A. SYSTEM DESCRIPTION

The time-referenced scanning beam Microwave Landing System (MLS) has been adopted by ICAO as the standard precision approach system to replace ILS. MLS provides precision navigation guidance for alignment and descent of aircraft on approach to a landing by providing azimuth, elevation and distance. The system may be divided into five functions:

- 1/ Approach azimuth;
- 2/ Back azimuth;
- 3/ Approach elevation;
- 4/ Range; and
- 5/ Data communications.

With the exception of DME, all MLS signals are transmitted on a single frequency through time sharing. Two hundred channels are available between 5031 and 5090.6 MHz. By transmitting a narrow beam which sweeps across the coverage area at a fixed scan rate, both azimuth and elevation may be calculated by an airborne receiver which measures the time interval between sweeps. For the pilot, the MLS presentation will be similar to ILS with the use of a standard CDI or multi-function display.

B. ILS LIMITATIONS

The Instrument Landing System (ILS) has served as the standard precision approach and landing aid for the last 40 years. During this time it has served well and has undergone a number of improvements to increase its performance and reliability. However, in relation to future aviation requirements, the ILS has a number of basic limitations:

- 1/ site sensitivity and high installation costs;
- 2/ single approach path;
- 3/ multi path interference; and
- 4/ channel limitations - 40 channels only.

C. MLS ADVANTAGES

As previously mentioned, ILS has limitations which prohibit or restrict its use in many circumstances. MLS not only eliminates these problems; but also offers many advantages over ILS including:

- 1/ elimination of ILS/FM broadcast interference problems;
- 2/ provision of all-weather coverage up to ± 60 degrees from runway centerline, from 0.9 degree to 15 degrees in elevation, and out of 20 NM;
- 3/ capability to provide precision guidance to small landing areas such as roof-top heliports;
- 4/ continuous availability of a wide range of glide paths to accommodate STOL and

- VTOL aircraft and helicopters;
- 5/ accommodation of both segments and curved approaches;
- 6/ availability of 200 channels - five times more than ILS;
- 7/ potential reduction of CAT I minimums;
- 8/ improved guidance quality with fewer flight path corrections required;
- 9/ provision of back-azimuth for missed approaches and departure guidance;
- 10/ elimination of service interruptions caused by snow accumulation; and
- 11/ lower site preparation, repair, and maintenance costs.

D. APPROACH AZIMUTH GUIDANCE

The approach azimuth antenna normally provides a lateral coverage of 40° either side of the centre of scan (Fig. 2-87). Coverage is reliable to a minimum of 20 NM from the runway threshold and to a height of 20,000 ft. The antenna is normally located about 1000 ft. beyond the end of the runway.

E. BACK AZIMUTH GUIDANCE

The back azimuth antenna provides lateral guidance for missed approach and departure navigation. The back azimuth transmitter is essentially the same as the approach azimuth transmitter. However, the equipment transmits at a somewhat lower data rate because the

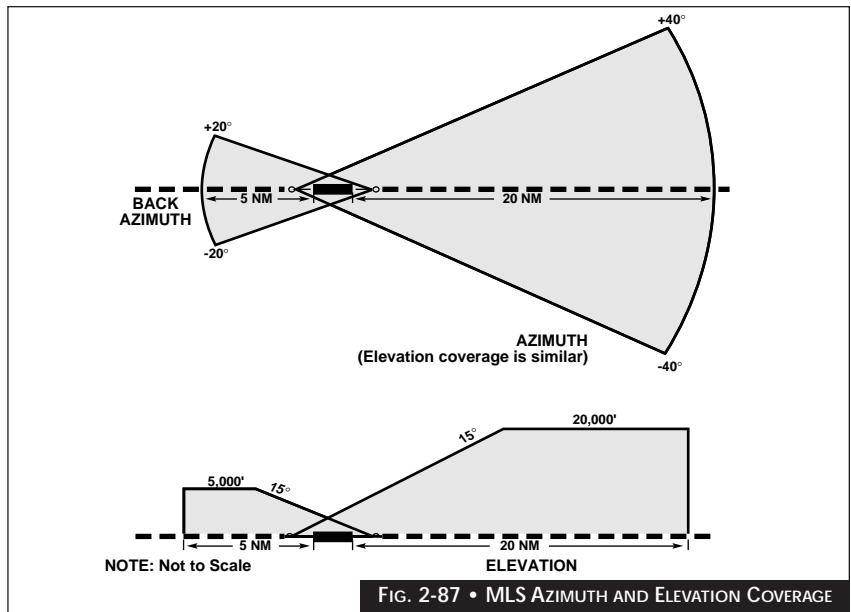

guidance accuracy requirements are not as stringent as for the landing approach. The equipment operates on the same frequency as the approach azimuth but at a different time in the transmission sequence. On runways that have MLS approaches on both ends, the azimuth equipment can be switched in their operation from the approach azimuth to the back azimuth and vice versa. Fig 2-87 shows MLS azimuth coverage volumes.

F. ELEVATION GUIDANCE

The elevation station transmits signals on the same frequency as the azimuth station. The elevation transmitter is normally located about 400 ft from the side of the runway between the threshold and the touchdown zone. Fig. 2-87 shows coverage volumes for the MLS elevation signal. It allows for a wide range of glide path angles selectable by the pilot.

G. RANGE GUIDANCE

Range guidance, consistent with the accuracy provided by the azimuth and elevation stations, is provided by the MLS precision DME (DME/P). DME/P has an accuracy of ± 100 ft as compared with ± 1200 ft accuracy of the standard DME system. In the future it may be necessary to deploy DME/P with modes which could be incompatible with standard airborne DME receivers.

H. DATA COMMUNICATIONS

The azimuth ground station includes data transmission in its signal format which includes both basic and auxiliary data. Basic data may include approach azimuth track and minimum glide path angle. Auxiliary data may include additional approach information such as runway condition, wind-shear or weather.

2.2.9 AREA NAVIGATION

A. GENERAL

Area Navigation (RNAV) can be defined as a method of navigation that permits aircraft operation on any desired course within the coverage of station-referenced navigation signals or within the limits of a self contained system capability, or a combination of these.

RNAV was developed to provide more lateral freedom and thus more complete use of available airspace. This method of navigation does not require a track directly to or from any specific radio navigation aid, and has three principal applications:

- 1/ A route structure can be organized between any given departure and arrival point to reduce flight distance and traffic separation;
- 2/ Aircraft can be flown into terminal areas on varied pre-programmed arrival and departure paths to expedite traffic flow; and
- 3/ Instrument approaches can be developed and certified at certain airports, without local instrument landing aids at that airport.

Navigation systems which provide RNAV capability include VOR/DME, DME/DME, LORAN C, GPS, OMEGA and self contained Inertial Navigation Systems (INS) or Inertial Reference Systems (IRS).

B. VOR/DME

A common general aviation RNAV system is the track-line computer (TLC), based on azimuth and distance information from a VORTAC. It is also called the *RHO-THETA system*. With the track-line computer the pilot effectively moves or off-sets the VORTAC to any desired location if it is within reception range. This “phantom station” is created by setting the distance (RHO) and the bearing (THETA) of the waypoint from

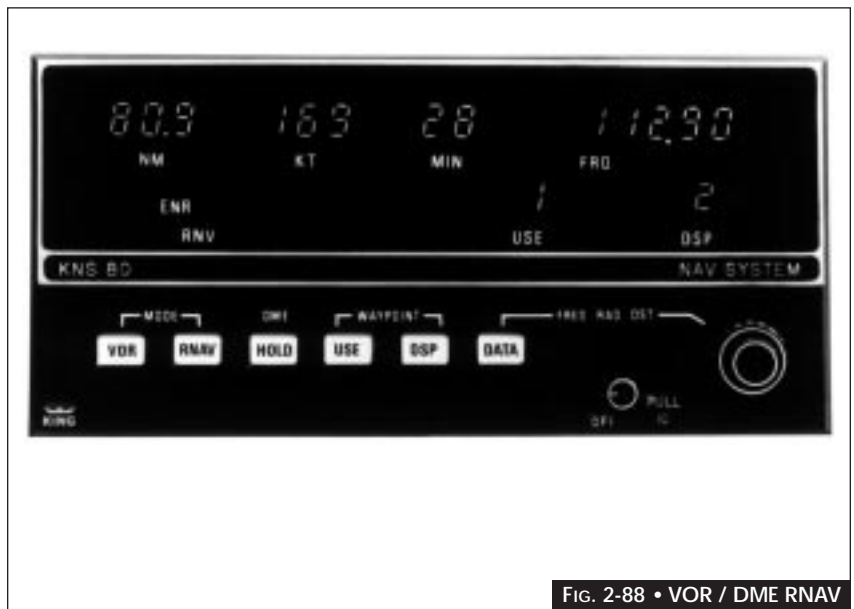

Fig. 2-88 • VOR / DME RNAV

a convenient VORTAC in the appropriate windows of the waypoint selector (Fig. 2-88). A series of these “phantom stations” or waypoints make up an RNAV route.

Fig. 2-89 illustrates how the VOR/DME RNAV is used to navigate from Belgrade to Haines on a direct route. This route crosses the 180° radial 23 NM south of the Mystic VORTAC. Therefore, the pilot sets *waypoint #1* as 180/23 on the control panel. *Waypoint #2* is 15 NM from MEEKER VORTAC on the 360° radial, or 360/15 on the panel. *Waypoint #3* is 360/22.

The direct route from Belgrade to Haines is 191 NM, 24 NM less than the VICTOR airway route.

The pilot could also place *waypoint #3* on the destination airport, allowing navigation from *waypoint #2* direct to the Haines airport. The DME readout would give a constant indication of the remaining distance to the destination. The pilot would specify *waypoint #3* as 064/49 (in reference to the MILTON VORTAC). Modern Flight Management Systems (FMS) often use DME/DME (RHO-RHO) systems which compare numerous DME signals (when coverage is available) to provide position and time and distance information.

LORAN-C system inaccuracies are mainly attributable to distance from the ground station, receiver geometry relative to ground transmitter baselines, and propagation anomalies associated with the earth's surface.

Because of the good repeatable accuracy of LORAN-C where adequate signal strength is available, the system has the potential to be used

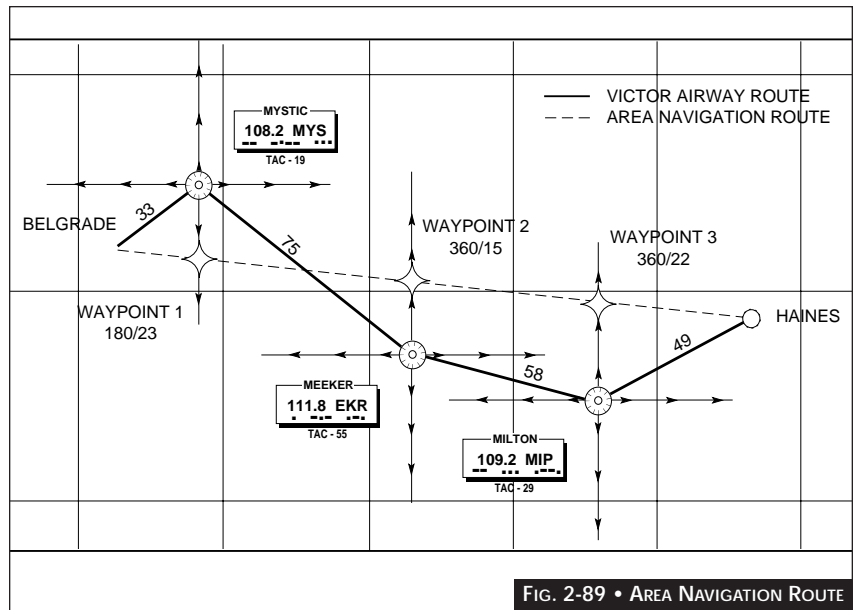

FIG. 2-89 • AREA NAVIGATION ROUTE

C. LORAN-C

LORAN-C is a pulsed hyperbolic system operating in the 90 to 110 kHz frequency band which is used for marine and air navigation where signal coverage is available. The system is based upon the measurement of the time difference in the arrival of signal pulses from a group or chain of stations. A chain consists of a master station linked to a maximum of four secondary stations with all of the signals synchronized with the master. The LORAN-C receiver measures the time difference between the master and at least two of the secondaries to provide a position fix.

The North American LORAN-C coverage area is limited to the continental United States, southern Canada and the east and west coasts (See Fig. 2-90). *A.I.P. Canada* and the applicable equipment manufacturers manuals should be consulted for updated coverage information and station selection recommendations.

for non-precision approaches. Most LORAN-C receivers used in general aviation are approved for VFR use only. Equipment that is *approved for IFR use* should be clearly indicated in the aircraft or in the aircraft log books. It is the

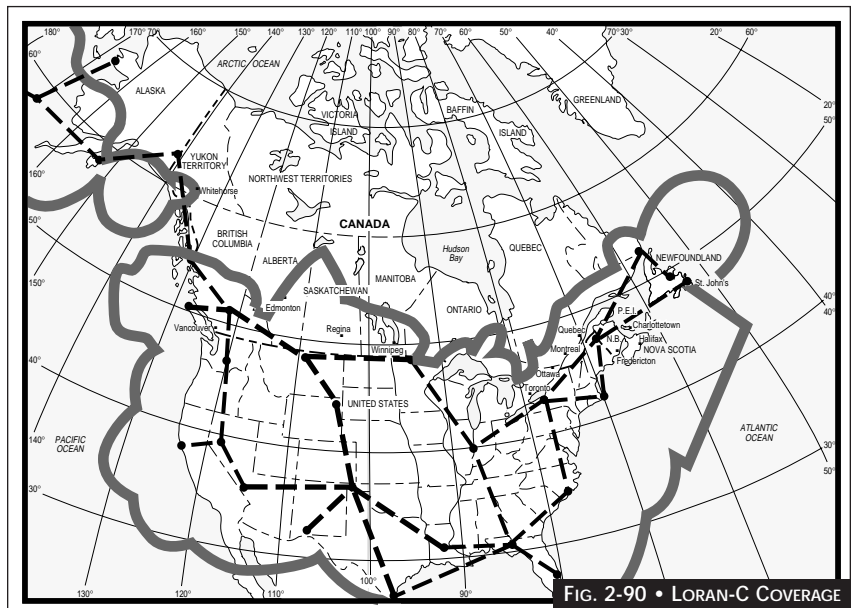

FIG. 2-90 • LORAN-C COVERAGE



pilot's responsibility to ascertain the IFR approval status of installed LORAN-C equipment before commencing an IFR flight.

D. GPS (GLOBAL POSITIONING SYSTEM)

GPS is a satellite positioning system developed by the United States Department of Defence (DOD) for use on land, sea and in the air. It will likely be the major component of the ICAO - designated *GNSS - Global Navigation Satellite System*. The full GPS constellation has 24 operational satellites to provide continuous, highly accurate three-dimensional position information globally. The Russian GLONASS system and European INMARSAT may add satellites to the GNSS constellation to provide redundancy.

1. *HOW DOES GPS WORK?:* Operating in 11,900 NM orbits, each satellite continuously transmits signals on 1227.6 and 1575.42 MHz. The GPS receiver automatically selects the signals from four or more satellites to calculate a three-dimensional position, velocity and time. Using the un-encrypted coarse acquisition navigational signal (C/A code) which will be available to all civil users, system accuracy will be at least 100 metres horizontally and 140 metres vertically, 95% of the time. Unlike ground based navigation systems, GPS provides global coverage with virtually no signal inaccuracies associated with propagation in the earth's atmosphere. Signal masking can occur with mountainous terrain, man-made structures and with poor antenna location on the aircraft. It is significant that *GPS accuracy is better than anything we have had before* for en route and non-precision approach guidance.

Each GPS satellite has 4 atomic clocks on board, because precise timing is the key to GPS navigation; this guarantees an accuracy of one nanosecond, or one billionth of a second. The satellites broadcast this time along with data used by receivers to calculate satellite position.

The performance of the satellites is monitored by stations located around the world, and a master control station in Colorado Springs has the capability to send

up corrections if errors are detected.

In addition to accurate 3-D position information, GPS also gives a direct reading of velocity - both speed and direction of motion. This means that displayed groundspeeds are very responsive to actual speed changes, and pilots will notice a marked improvement over groundspeeds generated by DME or LORAN-C. The availability of direction of motion allows quicker warning of off-course deviations, making for smoother operation.

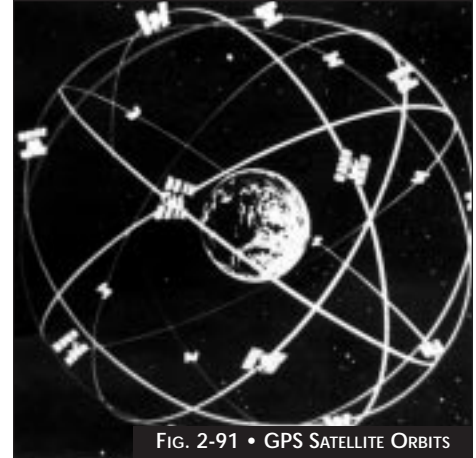

FIG. 2-91 • GPS SATELLITE ORBITS

2. *DIFFERENTIAL GPS:* Differential techniques can be used to achieve the accuracy required for more demanding operations. This is done by locating a receiver on the ground at a precisely-surveyed position. This receiver is also able to calculate the errors in the satellite signals. These errors can be data linked to aircraft in the form of corrections which can be applied by the aircraft receiver to reduce position error to as low as 2 to 5 metres.

There are two types of differential: *local* and *wide area*; local is essentially described above. Wide area differential would use ground stations spaced hundreds of miles apart feeding a master control station which would send correction data up to geostationary satellites.

3. *ACCURACY, AVAILABILITY AND INTEGRITY:* Aviation navigation systems must meet stringent accuracy, availability and integrity requirements. Accuracy and availability are obvious. Integrity is the ability of the system to warn a user when there is something wrong with the system. For example, ILS signals are monitored electronically, and if the monitors detect a malfunction they must shut down the ILS within 6 seconds. This results in a flag on the flight deck and a missed approach.

One way to achieve integrity is through receiver design, and the GPS receiver TSO

C-129 calls for *Receiver Autonomous Integrity Monitoring (RAIM)*. RAIM requires at least 6 satellites in view. The more the better. RAIM works by comparing position solutions using different combinations of satellites. Comparing these solutions can lead to the conclusion that a satellite is broadcasting incorrect data, and the receiver can then ignore that satellite.

WARNING:

Only GPS receivers which meet TSO C-129 are currently approved as the primary navaid for IFR operations. If this standard is not met, grossly incorrect data may be supplied by the satellite with no error indication.

4. **GPS APPROACHES:** GPS is approved for non-precision approaches (NPAs), including VOR, VOR/DME, NDB and NDB/DME. This approval is subject to certain criteria:

- a/ receiver meets TSO C-129 standard;
- b/ all approach waypoints must be in the avionics database;
- c/ all approaches which may be flown using GPS must be listed in the *Canada Air Pilot*.

Using differential techniques, GPS should be capable of providing sufficiently accurate and reliable data to allow precision approaches to Category I minima. It is theoretically possible that GPS could even be used for Category II or III approaches; however, it is not certain if all the integrity issues necessary for these approaches can be resolved. See *AIP Canada* for more information on GPS overlay and standalone approaches.

5. **EN ROUTE AND TERMINAL OPERATIONS:** GPS may be used as the primary IFR flight guidance for oceanic, domestic en route and terminal operations if the following provisions and limitations are met:

- a/ the GPS navigation equipment used must be approved in accordance with the requirements specified in TSO C-129, and operated in accordance with the approved flight manual or flight

manual supplement; and

- b/ monitoring of the traditional navigation equipment is necessary except for installations which use RAIM for integrity monitoring. Monitoring is also required when there are insufficient satellites in view for RAIM to operate; and



FIG. 2-92 • GPS RECEIVER

- c/ for NAT MNPS navigation a GPS installation with TSO C-129 authorization may be used to replace one of the other approved means of long-range navigation. For flight within CMNPS or RNP-C airspace GPS may serve as the sole long-range navigation system.

NOTE:

If there is a discrepancy between GPS and the traditional NAVAID(s), the pilot must revert to the traditional NAVAID(s) for navigation.

E. OMEGA

Omega is a network of eight VLF transmitting stations located throughout the world to provide worldwide signal coverage for marine and air navigation. These stations transmit precisely timed signals in the VLF band (10-13 kHz). Because of the low frequency, signals can be received to ranges of thousands of miles. Omega signals are affected by propagation variables which may degrade fix accuracy. These variables include daily variation of phase velocity, polar cap absorption, and sudden solar activity. Precipitation static and other electrical activity can also affect system operation. Omega provides a normal system accuracy of 2 to 4 NM worldwide.

With certain limitations, OMEGA navigation systems are approved for en route IFR within most classes of RNAV airspace. OMEGA is not approved for instrument approach procedures.

F. INS (INERTIAL NAVIGATION SYSTEM)

- 1. **THE SYSTEM:** Inertial Navigation Systems (INS) are *completely self-contained* and



independent of ground based navigation aids. After being supplied with initial position information, it is capable of updating with accurate displays of position, attitude and heading. It can calculate the track and distance between two points, display cross track error, provide ETAs, ground speed and wind information. It can also provide guidance and steering information for the autopilot and flight instruments.

The system consists of the *inertial platform*, *interior accelerometers* and a *computer*. The platform, which senses the movement of the aircraft over the ground, contains two gyroscopes. These maintain their orientation in space while the accelerometers sense all direction changes and rate of movement. The information from the accelerometers and gyroscopes is sent to the computer, which corrects the track to allow for such factors as the rotation of the earth, the drift of the aircraft, speed, and rate of turn. The aircraft's attitude instruments may also be linked to the inertial platform.

The accuracy of the INS is dependent on the accuracy of the initial position information programmed into the system. Therefore, system alignment before flight is very important. Accuracy is very high initially following alignment, and decays with time at the rate of about 1-2 NM per hour. Position updates can be accomplished in flight using ground based references with manual input or by automatic update using multiple DME or VOR inputs.

2. **OPERATION:** To operate a typical system, power is applied and the INS is activated. As the gyro's spin up and the platform is aligned with the aircraft's attitude, a keyboard (Fig. 2-93) is used to advise the system of the aircraft's present position, normally in terms of latitude and longitude, and magnetic variation. This information is integrated into a mathematical model within the computer and, by a procedure known as *gyrocompassing*, the system reckons its north reference point.

As the system is aligning, the co-ordinates of each *waypoint* along a planned route are

entered into the computer. Additional information such as ground tracks, ground speed, and desired ETAs may also be entered in some systems.

Once airborne, the required information is normally displayed on a control display unit (CDU) in either a CRT or digital format (Fig. 2-93). The INS may also be interfaced with other equipment and instruments in the aircraft. For example, a HSI may receive and display the information or an auto pilot may be connected to the INS so the navigation information may be used to manoeuvre the aircraft.

En route, the pilot recalls the desired waypoint from the computer. The computer provides and displays steering and distance information to the aircraft's normal navigation instruments. Alterations or deviations from the preplanned route may be carried out by simply entering the co-ordinates of the new desired waypoint into the computer.

3. **ERRORS:** Many factors contribute to errors in an inertial navigation system. In-flight errors arise from imperfections in gyros, accelerometers and computers. Initial misalignment may cause additional errors. Some errors and their effects are discussed in the following paragraphs.

Initial Levelling. If the platform is not correctly levelled the resultant tilt angle will allow the accelerometer to "see" the effect of gravity and thus have outputs besides true vehicle accelerations. The result of this is distance errors.

Accelerometers. The imperfect sensitivity and alignment of the accelerometers from which all information is drawn will lead to velocity and distance errors.

Integrator Errors. Integration errors may be due to drift, faulty calibration, non-linearity of errors in the initial conditions established



(rounding off in the equation). Depending on which stage of integration the errors occur, they may or may not increase with time and may be in any of the velocity, distance or position solutions.

Initial Azimuth Misalignment. An error due to misalignment in azimuth will give rise to velocity errors. Once integrated these velocity errors will lead to ever increasing distance and position errors.

Levelling Gyro Drift. The random precession of gyros will tend to turn the platform away from the horizontal causing an oscillation action as the accelerometers try to correct. This oscillation, depending on its period, will cause velocity and subsequent distance errors.

Azimuth Gyro Drift. Small position errors may occur due to azimuth gyro drift. However, gyro drift about the azimuth axis produces in-flight azimuth errors that are small compared to the initial misalignment errors in azimuth.

Computer Errors. Errors in the computer are attributable to two basic causes; hardware limitations and approximations made in deriving equations. As modern digital computers eliminate most hardware/software problems only minor approximation errors remain.

4. *RING LASER GYRO:* The ring laser gyro is a triangle shaped device with a silicone body and a gas filled cavity. A cathode and two anodes are used to excite the gas and produce two laser beams travelling in opposite directions. Reflectors in each corner are used to reflect the lasers around the unit's body.

If the two laser beams travel the same distance, there will be no change in their frequency. However, if the unit is moved (accelerated), one light beam will travel a greater distance to the detector than the other beam. The beam travelling the greater distance will have a lower frequency than the beam travelling the shorter distance. The detector analyzes these frequency changes and sends the

information to the computer, which then translates the data into movement in space.

5. *RING LASER GYRO IN AN INS:* By using three ring laser gyros and three accelerometers placed at right angles, it is possible to interpret all movement of the aircraft in space. This type of system has no moving parts and makes it ideal for "strapdown" inertial systems.
6. *THE STRAPDOWN INS:* A strapdown INS is one that is "hard mounted" to the aircraft. There is no need for a stabilized platform such as that utilized in a conventional INS (Fig. 2-94).
7. *ADVANTAGES OF A RLG:* The ring laser gyro INS combines high accuracy, low power requirements, small size and light weight with an instant alignment capability. In addition, because there are no moving parts involved, the ring laser gyros INS generally has a very high serviceability rate.
8. *PILOT PROCEDURES:* Most gross navigational errors associated with INS or ONS navigation involve *pilot error rather than equipment error*. It is extremely important that proper INS procedures are followed when entering waypoints and using the INS for navigation. In particular, cross-check of all data by both pilots is essential prior to entering it into the system for navigation. See the *North Atlantic MNPS Operations Manual* for more detailed guidance.

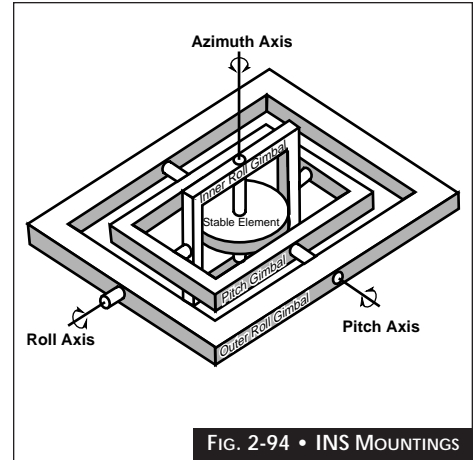

G. FMS (FLIGHT MANAGEMENT SYSTEMS)

Flight management system (FMS) is the term used to describe an integrated system that uses navigation, atmospheric and fuel flow data from several sensors to provide a centralized control system for flight planning, and flight and fuel management. The system processes navigation data to calculate and update a best computed position based on the known system accuracy and reliability of the input sensors. This system may also be referred to as a *multi-sensor RNAV*. FMS controls differ widely between aircraft types and manufacturers, but Fig. 2-95 gives a typical arrangement.

The heart of any FMS is the navigation computer unit. It contains the micro processor and navigation data base. A typical *data base* contains a regional or worldwide library of navaids, waypoints, airports and airways.

FMS sensor input is supplied from external DME, VOR, air data computer (ADC) and fuel flow sensors. Usually one or more long range sensors such as INS, IRS, ONS, LORAN-C or GPS are also incorporated. Depending on the capabilities of the navigation sensors, most flight management systems are approved for en route IFR in most classes of RNAV airspace. Instrument approach procedures based on multi sensor FMS equipment are being introduced in Canada. An example is shown at Fig. 4-42.

H. AIRSPACE

With the development of reliable and accurate RNAV systems, both domestic and oceanic airspace were reorganized to make use of rigid RNAV performance specifications. Examples of current RNAV airspace are:

- 1/ the North Atlantic Minimum Navigation Performance Specifications (NAT MNPS) airspace uses the North Atlantic Organized Track System (OTS) based on accurate RNAV separation criteria (Fig. 3-12);
- 2/ the Northern Track System and Arctic Track System in the Northern and Arctic Control Areas are based on the Canadian Minimum Navigation Performance Specifications (CMNPS) (Fig. 3-11); and
- 3/ domestically, the Required Navigation Performance Capability (RNP) Airspace has been developed to make use of both

random and fixed RNAV routes (this includes all of southern Canada) (Fig. 3-11).

At present there are three types of RNAV routes available in Canadian airspace besides the organized track system:

- 1/ *Random routes* at FL 390 and above;
- 2/ *Fixed T-routes* between city pairs FL 310 and above (see CFS); and
- 3/ *Minimum Time Tracks (MTT)* between various city pairs available by NOTAM daily (MTTs are on a trial basis only).

TYPE	DESCRIPTION	ALTITUDES
Random	Random Routes	FL390 or above
T-Routes	Fixed routes between city pairs	FL310 or above
MTT	Minimum Time Track-certain city pairs by NO TAM	Between FL350-FL390

FIG. 2-96 • CANADIAN RNAV ROUTES

For more detailed information and actual boundaries of MNPS, CMNPS and RNP airspace, refer to *AIP Canada* and the *Designated Airspace Handbook* (TP 1820).



FIG. 2-95 • TYPICAL FMS CONTROL UNIT

2.3

BASIC INSTRUMENT FLYING

2.3.1

ATTITUDE INSTRUMENT FLYING

A. INTRODUCTION

The purpose of this section is to provide a brief review of the techniques of attitude instrument flight, including stall and stall recovery manoeuvres. For a more detailed explanation and for a description of more instrument manoeuvres, see exercise 24 of the *Flight Training Manual (FTM)*.

Attitude instrument flying is an extension of the concept of attitude flying. The establishment of a specific pitch and bank attitude, accompanied by a designated power setting, will cause predictable aircraft performance. Therefore, if pitch, bank and power are determined through reference to the flight instruments and the desired performance is confirmed by these instruments, the definition and technique of attitude instrument flight is clearly evident.

There are three basic ingredients to attitude instrument flying:

- 1/ scan;
- 2/ interpretation; and
- 3/ aircraft control.

The human body is subject to sensations which are unreliable when interpreting the aircraft's actual attitude; therefore, the pilot must learn to disregard these sensations and control the aircraft through proper scan and interpretation of the flight instruments.

Proper *scan* is vital to the instrument pilot. Of course, instrument flying requires that certain instruments be used more often during particular manoeuvres. This is called *selective radial scan*. During a constant airspeed climb, for instance, the altimeter is less important than the airspeed indicator. Under instrument meteorological conditions, the pilot uses the attitude indicator to determine the aircraft's pitch and re-establish an attitude that will correct the airspeed to the desired value.

The attitude indicator replaces the normal outside visual references; therefore, it is the principal attitude control instrument for the radial scan. When scanning, the pilot should regard the attitude indicator as the hub of a "wagon wheel", and the other instruments as spokes. (Fig. 2-97).

The second important ingredient in instrument flying is proper instrument *interpretation*. The attitude indicator provides an artificial horizon to replace the natural one; hence, proper interpretation is extremely important. See the *FTM* p. 151 for more detail.

The last ingredient, *aircraft control*, results from scan and interpretation. It is simply a matter of applying the proper control pressures to attain the desired aircraft performance. These pressures are the same as in visual flight except that smaller and smoother control inputs are required.

B. CONCEPT

The concept of control and performance attitude instrument flying can be applied to any aspect of instrument flight. Under this concept, instruments are divided into three broad categories: *control*, *performance* and *navigation*.

1. **CONTROL INSTRUMENTS:** Control instruments indicate *attitude of the aircraft and power* (thrust/drag) being supplied to the aircraft. These instruments are calibrated to permit adjustments in definite amounts. They include the attitude indicator and engine control instruments (tachometer, manifold pressure, RPM, EPR).
2. **PERFORMANCE INSTRUMENTS:** Performance instruments indicate the *actual performance of the aircraft* which can be determined from the airspeed/mach, turn-and-bank, vertical speed indicators, altimeters, heading indicator, turn co-ordinator, magnetic compass.
3. **NAVIGATION INSTRUMENTS:** Navigation



FIG. 2-97 • ATTITUDE INDICATOR IS CENTRE OF SCAN



instruments indicate the *position of the aircraft* in relation to a particular navigational aid that has been selected. These can include NDB, VOR, ILS, INS, GPS, Loran C, and Omega.

C. ATTITUDE AND POWER CONTROL

Proper control of aircraft attitude is the result of knowing when and how much to change attitude, and then smoothly changing it by a definite amount. Aircraft attitude control is accomplished by proper use of the attitude indicator. The attitude indicator provides an immediate, direct and corresponding indication of any change in aircraft pitch and/or bank attitude.

Pitch changes are accomplished by changing the pitch attitude of the reference line by set amounts in relation to the horizon bar. These changes are made in bar widths or degrees, depending upon the type of attitude indicator. On most attitude indicators a bar width represents approximately 2 degrees of pitch change.

Bank changes are accomplished by changing the bank attitude or bank pointers by set amounts in relation to the bank scale. Normally, the bank scale is graduated by 0, 10, 20, 30, 60 and 90 degrees, and this scale may be located at the top or bottom of the attitude indicator. Generally, an angle of bank that approximates the degrees to be turned is recommended; however, *it should not exceed 30 degrees in instrument flight*. The TAS and the desired rate of turn are factors to be considered.

Proper power control results from the ability to smoothly establish or maintain desired airspeeds in co-ordination with attitude changes. Power changes are accomplished by throttle adjustment and with reference to the power indicators. Little attention is required to ensure that the power indication remains constant once it is established, because these indications are not affected by such factors as turbulence, improper trim or inadvertent control pressures.

D. TRIM TECHNIQUE

The aircraft has been correctly trimmed when it maintains a desired attitude with all control

pressures neutralized. It is much easier to hold a given attitude constant by relieving all control pressures. In addition, more attention can then be devoted to the performance and navigation instruments and other cockpit duties.

First, apply control pressure to establish a desired attitude and then adjust the trim so that the aircraft will maintain that attitude when the flight controls are neutralized. Trim the aircraft for co-ordinated flight by centring the ball of the turn-and-slip indicator. This is done by using rudder trim in the direction the ball is displaced from centre.

Changes in attitude, power or configuration may require a trim adjustment. Independent use of trim to establish a change in aircraft attitude invariably leads to erratic aircraft control and is not recommended. Smooth and precise attitude changes are best attained by a combination of control pressures and trim.

E. SCAN TECHNIQUE

Scanning, or cross checking as it is sometimes known, is the *continuous and logical observation of flight instruments*. A methodical and meaningful instrument scan is necessary to make appropriate changes in aircraft attitude and performance.

The control and performance concept of attitude instrument flying requires that the pilot establish an aircraft attitude and power setting on the control instruments which should result in the desired aircraft performance. The pilot must be able to recognize the requirements for a change in attitude or power or both. By cross-checking the instruments properly (scan), the pilot can determine the magnitude and direction of adjustment required to achieve the desired performance.

Scan can be reduced to the proper division of attention and interpretation of the flight instruments. *Attention* must be efficiently divided between the control and performance instruments and in a sequence that will ensure



comprehensive coverage of the flight instruments. The pilot must quickly *interpret* what he or she sees when looking at the instruments and must become familiar with the factors to be considered in dividing his or her attention properly.

A factor influencing scan technique is the characteristic manner in which instruments respond to changes of attitude and power. The control instruments provide direct and immediate indications of attitude and power changes. Changes in the indications on the performance instruments will lag slightly behind changes of attitude or power. This lag is due to inertia of the aircraft and the operating principles and mechanisms of the performance instruments.

To develop the technique of always referring to the correct instrument at the appropriate time, you must continually *ask yourself these questions*:

- 1/ What information do I need?
- 2/ Which instruments give me the needed information?
- 3/ Is the information reliable?

As mentioned earlier, the attitude indicator is the only instrument that the pilot should observe for any appreciable length of time. It is also the instrument that the pilot should observe the greatest number of times. An example of a scan demonstrates this; the pilot glances from the attitude indicator, then a glance at the airspeed indicator, back to the attitude indicator, and so forth (wagon wheel technique or *radial scan*). Of course different phases of flight will require slightly different scan techniques. This is called *selective radial scan* since the pilot will use particular instruments to carry out a particular task.

A correct or incorrect scan can be recognized by analyzing certain symptoms of aircraft control. Symptoms of insufficient reference to the control instruments are readily recognizable. The pilot should have some definite attitude and power indications in mind that should be maintained. If the performance instruments fluctuate erratically through the desired indications, then the pilot is probably not referring sufficiently to the control instruments. This lack of precise aircraft control is called

chasing the indications.

Too much attention to the control instruments can be recognized by the following symptoms — if the pilot has a smooth, positive and continuous control over the indications of the control instruments but large deviations are observed to occur slowly on the performance instruments, a closer scan of the performance instruments is required.

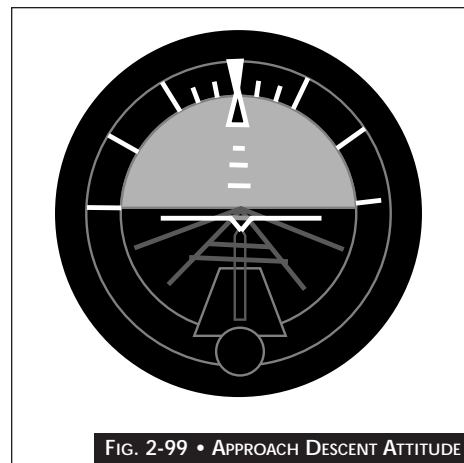

FIG. 2-99 • APPROACH DESCENT ATTITUDE

The indications on some instruments are not as eye-catching as those on other instruments. For example, a 4-degree heading change is not as obvious as a 300 to 400-feet-per-minute change on the vertical-speed indicator. Through deliberate effort and proper habit, the pilot must ensure that all the instruments are included in the scan. If this is accomplished, deviations on the performance instruments should be observed in their early stages.

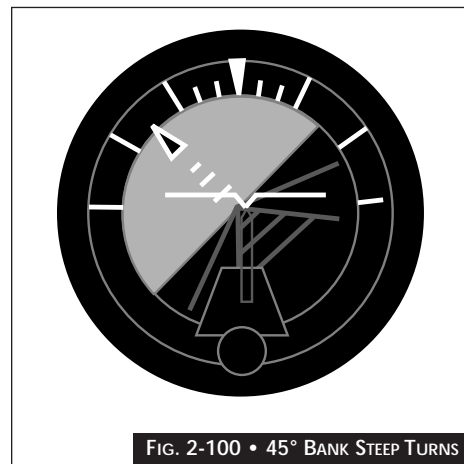

FIG. 2-100 • 45° BANK STEEP TURNS

A correct scan results in the continuous interpretation of the flight instruments, which enables the pilot to maintain proper aircraft control at all times. Remember, rapidly looking from one instrument to another without interpretation is of no value. Instrument systems and the location of the flight instruments vary. Pilot ability also varies. Therefore, *each pilot should develop their own rate and technique of checking the instruments* which will ensure a continuous and correct interpretation of the flight instruments. Refer to the *Flight Training Manual*, Exercise 24 for a more detailed explanation and examples of scan techniques during various stages of flight.

F. ADJUSTING ATTITUDE AND POWER

The control and performance concept of attitude instrument flying requires the adjustment of aircraft attitude and power to achieve the desired performance in relation to the capabilities of your aircraft. A change of



aircraft attitude and/or power is required when any indication other than that desired is observed on the performance instruments. However, it is equally important for the pilot to know what to change and how much of a pitch, bank or power change is required.

The phrase “**Attitude plus power equals performance**” summarizes the philosophy behind instrument flying. In other words, an aircraft’s performance is the product of attitude and power. Performance is expressed in terms of airspeed, altitude, rate of climb or descent, or other criteria. If either attitude or power is changed, a change in performance will result.

The pilot knows what to change by understanding which control instrument to adjust to achieve the desired indications on the performance instruments. Bank attitude control is used to maintain a heading or a desired angle of bank during turns. Power control, in conjunction with a slight attitude change, may be used for maintaining or changing the airspeed while at a constant altitude. Power may also be used to establish a rate of climb or descent at a given airspeed or trim setting.

How much to adjust the attitude or power or both is, initially, an estimate based on familiarity with the aircraft and the amount the pilot desires to change the indications on the performance instruments. After making a change of attitude or power, the pilot should observe the performance instruments to see if the desired change has occurred. If it has not, further adjustment is required.

To sum up, *instrument flight is a continuous process of:*

- a/ establishing an attitude and power setting on the control instruments;
- b/ trimming;
- c/ scanning; and
- d/ adjusting.

These procedural steps can be applied to any instrument manoeuvre and should result in precise attitude instrument flying.

2.3.2

ATTITUDE INSTRUMENT FLYING MANOEUVRES

The following manoeuvres are described in the *Flight Training Manual* for full and partial panel and will not be duplicated here:

- 1/ Straight-and-Level Flight;
- 2/ Climbing;
- 3/ Descending;
- 4/ Turns;
- 5/ Steep Turns;
- 6/ Change of Airspeed; and
- 7/ Unusual Attitudes and Recoveries.

A. STALLS AND STALL RECOVERY

There are many different configurations from which to enter stall manoeuvres; however, for the purpose of this section, stalls will be discussed in reference to the realm of operations most frequently encountered in instrument flight. The entry procedures described are designed for training pilots to recover from induced stalls for training purposes. These manoeuvres should be accomplished in VMC at a safe altitude - normally with recovery planned for a minimum of 3000 ft. AGL. See the Aircraft Flight Manual for recommended procedures.

1. APPROACH STALLS:

Straight-ahead: In the approach mode stall, the pilot establishes the aircraft in the configuration suitable for the type of aircraft, i.e., flaps and undercarriage positioned as specified in the aircraft flight manual as appropriate for an approach to landing.

The pilot must maintain altitude by constantly increasing elevator back pressure as the airspeed decreases toward the approach speed. When the approach speed is attained, the pilot should decrease the pitch attitude of the miniature aircraft in the attitude indicator to initiate a descent. When the aircraft is established in a constant-rate, straight-ahead descent at approach speed the pilot should increase the pitch attitude to approximately the second pitch reference line above the horizon (normally 10°) to purposely induce

a stall in this configuration. The pilot must maintain the selected pitch attitude and remain on the heading from which the manoeuvre was begun.

The pilot should start recovery when buffeting begins, by simultaneously lowering the miniature aircraft to the horizon (or as required in the AFM) on the attitude indicator and adding maximum allowable power. Maintaining the level flight attitude causes the airspeed to increase. Once the aircraft reaches a safe airspeed, the pilot should increase pitch to initiate a climb at this speed until reaching the altitude from which the manoeuvre began.

Turning: The pilot executes a turning approach stall in much the same manner as the straight-ahead approach stall (reducing power to the approach setting; maintaining altitude until the airspeed has decreased until the instrument indications have “settled down”). At this time the pilot increases the pitch attitude smoothly to the section pitch reference line above the horizon, and begins a 15° - 20° bank turn in either direction. The pilot maintains the pitch and bank through the use of the attitude indicator until buffeting occurs.

The recovery procedure is the same as for the straight-ahead approach stall except that the wings are to be levelled and the recovery heading is maintained. See the *FTM* section on Unusual Attitudes and Recoveries.

2. TAKE-OFF AND DEPARTURE STALLS:

Straight-ahead: The pilot reduces power to flight idle, or approximately 15 in. Hg manifold pressure, and maintains altitude, using the attitude indicator, vertical speed indicator and altimeter as references. As the airspeed decreases to lift-off speed, the pilot sets a wings-level, straight-ahead climb and increases power at a pitch angle that causes a power-on, straight-ahead stall.

The pilot accomplishes this by adjusting the pitch of the miniature aircraft to the second pitch reference line above the horizon (or as required in the aircraft type). The pilot

must also maintain the initial heading until a stall buffet occurs. As the air-speed decreases, the pilot must increase back elevator pressure to hold the pitch attitude selected. Direction and control must be maintained strictly by use of the rudder.

When the buffet occurs, the pilot should pitch down to the horizon bar, add maximum allowable power and allow the aircraft to accelerate. The recover altitude should be maintained and the manoeuvre completed on the same heading as used throughout the stall. After attaining climb airspeed, the pilot should reduce power to the climb setting.

Turning: The turning take-off and departure stall begins in the same manner as the straight-ahead departure stall. The pilot reduces power and maintains altitude. As the airspeed decreases to lift-off speed, the pilot increases the pitch to the second pitch reference line, applies increased power and a makes a 15°-20° bank in either direction. The pilot maintains this climbing turn attitude on the attitude indicator until a stall buffet occurs. To recover, the pilot lowers the pitch attitude to the horizon bar, levels the wings and maintains the recovery altitude and heading. As the airspeed approaches climb, the pilot should reduce power to the climb setting.

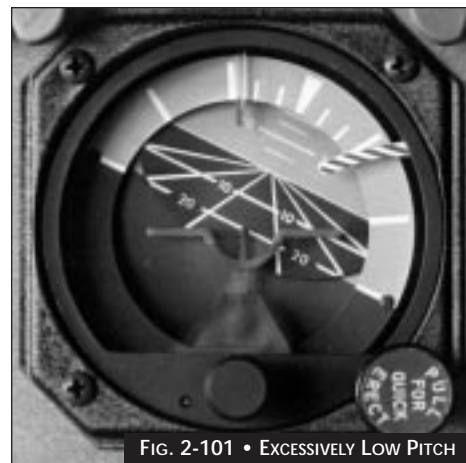

FIG. 2-101 • EXCESSIVELY LOW PITCH



**P
A
R
T

T
H
R
E
E**

AIR TRAFFIC SERVICES

- 3.1 INTRODUCTION TO AIR TRAFFIC SERVICES
- 3.2 CANADIAN AIRSPACE
- 3.3 IFR SEPARATION
- 3.4 RADIO PROCEDURES



3.1 INTRODUCTION TO AIR TRAFFIC SERVICES

3.1.1 AIR TRAFFIC SERVICES

AIRPORT CONTROL SERVICE is provided by airport control towers to all traffic on the manoeuvring area of an airport and to aircraft operating in the vicinity of an airport.

AREA CONTROL SERVICE is provided by Area Control Centres (ACCs) to IFR and controlled VFR flights operating within specified control areas.

CONFLICT RESOLUTION is resolution of potential conflicts between IFR/VFR and VFR/VFR aircraft that are radar identified and in communication with ATC.

TERMINAL CONTROL SERVICE is provided by IFR units (ACCs) or Terminal Control Units (TCUs) to aircraft operating within specified control areas.

TERMINAL RADAR SERVICE is additional service provided by IFR units to VFR aircraft operating within Class C, D and E airspace.

ALERTING SERVICE is notification of appropriate organizations regarding aircraft in need of search and rescue services, or alerting of crash equipment, ambulances, doctors and any other safety services.

FLIGHT INFORMATION SERVICE is advice and information provided by ATC, in addition to control information, to enhance the safety and efficiency of flight (refer to Article 3.1.2).

ALTITUDE RESERVATION SERVICE includes the services of the Airspace Reservation Unit (ARU) and Area Control Centres (ACCs) in provision of reserved altitudes for specified air operations in controlled airspace and in providing information concerning these reservations and military activity areas in controlled and uncontrolled airspace.

AIRCRAFT MOVEMENT INFORMATION SERVICE is provided by ACCs for the collection, processing and dissemination of aircraft movement

information for use by Air Defence Units relative to flights operating into or within Canadian Air Defence Identification Zones (CADIZ).

CUSTOMS NOTIFICATION SERVICE (ADCUS) is provided, on request, by ATC units for advance notification of customs officials for transborder flights at specified “ports of entry”. ADCUS information is contained in the *Canada Flight Supplement*.

GROUND CONTROL Provided by an airport or a ground controller to aircraft and vehicles on the manoeuvring area of the airport.

A. AIR TRAFFIC CONTROL

Air traffic is composed of all aircraft in flight and those operating on the manoeuvring area of an aerodrome.

Air traffic control (ATC) in Canada is handled by qualified personnel of the Canadian Forces, Transport Canada Aviation or may be provided by a private agency such as at the Southport airport. All control is predicated upon known traffic. Also, an aircraft may be under the control of only one ATC unit at any given time.

ATC OBJECTIVES: The objectives of ATC may be summarized as follows:

- a/ the maintenance of a safe, expeditious and orderly flow of traffic;
- b/ the prevention of collisions;
- c/ the provision of advice and information to pilots; and
- d/ the alerting of appropriate agencies when an aircraft needs assistance.

NOTE:

The provision of control services is normally the primary responsibility of an ATC unit.

B. FLIGHT SERVICE STATIONS - SERVICES

Approximately 100 flight service stations are staffed by flight service specialists whose primary responsibility is to provide efficient flight planning, flight information and advisory services to pilots. Flight service specialists work closely with other agencies in their provision of

services. They relay air traffic control instructions and aircraft position reports; disseminate meteorological information; and initiate and participate in searches for missing or overdue aircraft. Flight Service Stations offer the following services:

1. *PRE-FLIGHT PLANNING SERVICE*: The flight service specialist provides a pre-flight planning service accessible through walk-in, local telephone and long distance toll-free telephone to assist pilots in planning and conducting their flights safely. A comprehensive display of aviation and weather information with continual updating as new data becomes available is maintained at the FSS. The specialist informs the pilot of occurring or expected weather conditions along the proposed flight route, with emphasis on hazardous weather. A pilot may also obtain information on airways, status of NAVAIDs, communications facilities, special regulations, suggested routes, distances, landmarks, etc. Finally, specialists accept and process flight plans and flight notifications; and arrange for customs notification, when requested, for trans-border flights.

There are two types of weather information service:

The Aviation Weather *Information* Service consists of the provision of factual weather information obtained from actual weather reports, official weather forecasts and approved graphic or weather chart products but does not involve the interpretation of this information. This service is available from all FSS and is usually provided to flights whose destinations are within 500 miles from the station.

The Aviation Weather *Briefing* Service consists of the provision of meteorological information through the process of selection, interpretation, elaboration and adaptation of relevant charts and reports. At designated FSS the briefers are authorised to provide, in addition to factual weather information, an interpretation and adaptation of meteorological information to fit the changing weather situation and the special needs of the user, consultation and

advice on special weather problems; and, on request, flight documentation for long range flights. FSS designated to provide this service have access to weather information for North America, and in some cases, for Western Europe and/or the Pacific Rim area.

2. *AIRPORT ADVISORY SERVICE*: The airport advisory service is given to aircraft prior to takeoff or landing and is intended for the safe movement of aircraft at uncontrolled aerodromes. The service is delivered on the MF and consists of current data on runway - active or preferred, wind, altimeter, summary of known pertinent aircraft traffic, ground traffic, weather, NOTAM, and other relevant information. After the initial advisory, the specialist may request position reports to keep track of aircraft movement within the MF and will inform pilots of the positions and intentions of potentially conflicting traffic, thus allowing pilots to organize a safe traffic flow. This advisory service is also provided at selected airports with a collocated FSS and control tower when the tower is closed.
3. *VEHICLE CONTROL SERVICE*: The flight service specialist controls the movement of ground traffic on the airport manoeuvring area to provide for the safe movement of aircraft and ground traffic. Ground traffic does not include aircraft, however, it includes all other traffic such as vehicles, pedestrians and construction equipment. This service is also delivered at selected airports with a collocated FSS and control tower when the tower is closed.
4. *REMOTE AIRPORT ADVISORY AND REMOTE VEHICLE CONTROL SERVICES*: These services are similar to the Airport Advisory and Vehicle Control services previously describe for staffed facilities but are provided via a *Remote Communications Outlet*. The primary difference is that the flight service specialist is not located at the aerodrome for which the services are provided. Therefore, the specialist cannot observe the local weather conditions but must rely on reports from an *Automatic Weather Observing Station* or reports from other agencies. Also, pilots should be aware that the specialist cannot visually follow the



movement of aircraft traffic in the vicinity of the remote aerodrome and cannot ascertain visually that ground traffic has actually vacated the active runway. These factors should be considered by a pilot conducting a straight-in instrument approach in poor weather conditions at an aerodrome served by remote services.

5. *EN ROUTE FLIGHT INFORMATION SERVICE:* Flight Service Stations continuously monitor the frequency 126.7 to obtain PIREPs and VFR position reports and to pass flight safety information such as SIGMETs, AIRMETs, MANOTs, PIREPs, weather reports, terminal forecasts, NOTAM, and other updated information on unfavourable flight conditions or hazards along the route of flight about which the pilot may not be aware. In addition, FSS relay IFR position reports or ATC clearances in areas where aircraft are beyond the communications range of ATC facilities. Other activities are the reporting of ELT signals and the conduct of communications related to Security Control of Air Traffic and Air Navigation Aids (SCATANA).
6. *EMERGENCY SERVICES:* Flight Service Stations continuously monitor the frequency 121.5 to assist flight crews in the event of an emergency and report any aircraft in a declared state of emergency. Also, FSS equipped with direction-finding equipment, usually in remote locations, are able to provide homing and position assistance.
7. *VFR FLIGHT PLAN PROCESSING AND ALERTING SERVICE:* Specialists provide this service to VFR pilots. By accepting flight plans, the specialist accepts responsibility for search and rescue alerting and co-ordination. The flight plans are distributed to destination stations, and through the operation of a holding file, the specialist identifies aircraft that have failed to complete their flight within the specified time. If an aircraft is overdue, the specialist conducts a communications search throughout all probable areas along the route of flight, and co-ordinates the findings with Search and Rescue.

8. *WEATHER OBSERVING SERVICE:* At many airports, specialists are responsible for maintaining a continuous watch on weather conditions and conduct the observation, recording, and dissemination of surface weather data, including specials for aviation purposes.
9. *NAVIGATIONAL AIDS MONITORING SERVICE:* Specialists monitor all NAVAIDs to determine their operational status. Information about malfunctioning NAVAIDs is immediately reported to pilots and ATC to allow them to adjust their actions accordingly. Where appropriate, a NOTAM is issued to advertise the malfunction to other pilots at distant locations.
10. *BROADCAST SERVICE:* Specialists broadcast upon receipt, SIGMETs, selected PIREPs and reports of microburst activity. They also broadcast NOTAMs concerning equipment shutdown immediately prior to shutting down the equipment and again when service is restored. These broadcasts may be conducted on the en route frequency, an appropriate Remote Communications Outlet and the MF associated with the airport where the Flight Service Station is located. Specialists may also conduct Transcribed Weather Broadcast (TWB) and Pilots Automatic Telephone Weather Answering Service (PATWAS) at selected metropolitan locations where the demand for pre-flight weather information is high.

3.1.2

FLIGHT INFORMATION SERVICE

A. GENERAL

Air Traffic Control units assist pilots by supplying information about hazardous flight conditions. This information includes data that may not have been available to the pilot prior to take-off or describes recent conditions that have developed along the route of flight.

Pilots should remember that the *ATC service is established primarily to prevent collisions and expedite traffic.* The provision of this service must take precedence over the provision of flight information service, but ATC makes every

effort to provide flight information and assistance.

Whenever practicable, ATC makes flight information available to any aircraft in communication with an Air Traffic Control unit, prior to take-off or when in flight, except where such service is provided by the aircraft operator. Many factors, such as volume of traffic, controller workload, communications frequency congestion, and limitations of radar equipment, may prevent a controller from providing this service. Air Traffic Control provides IFR flights with information concerning:

- 1/ severe weather conditions;
- 2/ reported or forecast weather at the destination or alternate aerodrome;
- 3/ volcanic eruption or volcanic ash clouds;
- 4/ icing conditions;
- 5/ changes in the serviceability of NAVAIDS;
- 6/ conditions of airports and associated facilities;
- 7/ other items considered pertinent to the safety of flight.

Flight information messages are intended as information only. If ATC suggests a specific action, the controller prefixes the message with ATC SUGGESTS. The pilot must make the final decision concerning any suggestion.

Surveillance radar equipment is used frequently to provide information concerning severe weather conditions, chaff drops, bird activity and possible traffic conflicts. Due to limitations inherent in all radar systems, aircraft and weather disturbances, etc., cannot be detected in all cases.

B. BIRD ACTIVITY INFORMATION

Air Traffic Control provides information concerning bird activity, obtained through controller's observations or pilot reports, to aircraft operating in the area concerned. In addition, ATC warns pilots of possible bird hazards if radar observations indicate the possibility of bird activity. The information includes:

- 1/ size or species of bird, if known;

- 2/ location;
- 3/ direction of flight;
- 4/ altitude, if known.

C. CHAFF INFORMATION

Air Traffic Control provides pilots who intend to operate through the area concerned with all available information relating to proposed or actual chaff drops. Information includes:

- 1/ location of chaff drop area;
- 2/ time of drop;
- 3/ estimated speed and direction of drift;
- 4/ altitudes likely to be affected;
- 5/ relative intensity of chaff.

D. SEVERE WEATHER INFORMATION

When practicable, ATC provides flights with severe weather information pertinent to the area concerned. Pilots may assist ATC by providing reports of severe weather conditions that they encounter. Air Traffic Control attempts to suggest alternate available routes to keep aircraft away from areas of severe weather (refer to Article 3.1.8F).

E. AUTOMATIC TERMINAL INFORMATION SERVICE (ATIS)

Automatic Terminal Information Service (ATIS) is a continuous broadcast of recorded information for arriving and departing aircraft on a VOT or discrete VHF/UHF frequency. Automatic Terminal Information Service messages are recorded in a standard format and contain such information as:

- 1/ current weather at the airport, including ceiling and sky conditions, visibility, obstructions to visibility, temperature, dew point, surface wind including gusts, pertinent SIGMETS, AIRMETS and PIREPS, and altimeter setting;
- 2/ the type(s) of instrument approach and runway(s) in use for arriving aircraft;
- 3/ the runway(s) in use for departing aircraft.;
- 4/ NOTAMs or excerpts from NOTAM, pertinent information regarding the serviceability of NAVAIDS and field conditions that affect arriving or departing aircraft. (e.g. JBI and runway condition



reports will be included when applicable).

Each recording is identified by a phonetic alphabet code letter, beginning with ALFA. Succeeding letters are used for each subsequent message.

EXAMPLE: TORONTO INTERNATIONAL INFORMATION BRAVO. WEATHER AT 0300Z: TWO THOUSAND SCATTERED, MEASURED CEILING THREE THOUSAND OVERCAST, VISIBILITY FIVE, HAZE; TEMPERATURE ONE EIGHT; DEW POINT ONE FIVE; WIND ONE THREE ZERO AT TEN; ALTIMETER TWO NINER NINER TWO. APPROACH ILS RUNWAY ONE FIVE. LANDING ONE FIVE. DEPARTURES TWO FOUR LEFT. NOTAM GLIDE PATH ILS RUNWAY ZERO SIX RIGHT OUT OF SERVICE UNTIL FURTHER NOTICE. INFORM ATC ON INITIAL CONTACT YOU HAVE INFORMATION BRAVO.

NOTE:

Current time and RVR measurements are not included in the ATIS message, but rather are issued by the controller when required. Temperature and dewpoint information is derived only from the scheduled hourly weather observations.

Pilots hearing the broadcast should inform the ATC unit on first contact (centre, terminal, ground, tower, etc.) that they have received the information, by repeating the code word that identified the message. This eliminates the need for the controller to issue further information.

EXAMPLE: GABC 15 MILES EAST WITH INFORMATION BRAVO.

During periods of rapidly changing conditions that make it difficult to keep the ATIS message current, ATC records and broadcasts the following message:

BECAUSE OF RAPIDLY CHANGING WEATHER/AIRPORT CONDITIONS CONTACT ATC FOR CURRENT INFORMATION.

The success and effectiveness of ATIS depends largely upon the co-operation and participation

of airspace users; therefore, pilots should take full advantage of this service.

3.1.3 IDENTIFICATION OF AIR TRAFFIC CONTROL UNITS

Air Traffic Control units are identified by the name of the airport or location, followed by an appropriate indication of the unit or function.

EXAMPLES:

- | | |
|---------------------------|---|
| OTTAWA TOWER | airport control tower |
| OTTAWA GROUND | ground control function of control tower |
| OTTAWA CLEARANCE DELIVERY | IFR clearance delivery |
| CALGARY TERMINAL | terminal control unit |
| CALGARY ARRIVAL | arrival control function of terminal control unit |
| CALGARY DEPARTURE | departure control function of terminal control unit |
| MONCTON CENTRE | area control centre |
| KENORA RADAR | en route radar facility |

Because surveillance radar, where available, is used by all controllers in the provision of control service, normally it is not necessary to use the word “radar” in the identification of an ATC unit to obtain radar service.

3.1.4 UNITS OF MEASUREMENT

The following units of measurement are used in the Canadian ATC system:

SPEED - Knots or Mach Number.

DISTANCE - Nautical miles (NM), except in visibility, which is reported in statute miles, and runway visual range (RVR), which is expressed in feet.

ALTITUDE - Measured in feet, normally rounded off to the nearest 100, and generally expressed in the following terms:

- a/ Below 18000 ft - thousands and hundreds of feet.

EXAMPLE:

16000 ft - one six thousand feet
8500 ft - eight thousand five hundred feet

- b/ 18000 ft and above and in the standard pressure region below 18000 ft preceded by the term "Flight Level" and expressed in individual digits with the last two zeros omitted.

EXAMPLE:

22000 ft - Flight Level Two Two Zero
7000 ft - Flight Level Seven Zero (in the Standard Pressure Region)
5500 ft - Flight Level Five Five (in the Standard Pressure Region)

TIME: Coordinated Universal Time (UTC or "Z") and the 24 hour clock system are used for all operational purposes.

Time is normally expressed in four figures, the first two indication the hour past midnight, the last two including the minutes. When no misunderstanding is likely to occur, time may be expressed in minutes only (two figures).

The time group 0000Z is used to indicate the start of the new day, e.g., 152359Z, 160000Z.

TO CONVERT FROM	TO COORDINATED UNIVERSAL TIME	
STANDARD TIME (24-HOUR CLOCK)	NEWFOUNDLAND	ADD 3 1/2 HRS
	ATLANTIC	ADD 4 HRS
	EASTERN	ADD 5 HRS
	CENTRAL	ADD 6 HRS
	MOUNTAIN	ADD 7 HRS
	PACIFIC	ADD 8 HRS

Where *daylight saving time* is used, reduce these conversion factors by one hour.

Flight crews are responsible for ensuring the accuracy of their clocks or other time recording devices. *Time checks* are given to departing aircraft on initial contact with ground control or tower, and to other aircraft on request. These checks are expressed in four figures to the nearest minute, e.g., two two three four.

ALTIMETER SETTING (QNH): An altimeter

setting (QNH) indicates the height above sea level. In air-ground communications, the altimeter setting is expressed by stating the word "altimeter" followed by the four separate digits of the setting, indicating inches of mercury to the nearest hundredth.

EXAMPLE:

ALTIMETER, TWO NINER NINER SIX.

QFE (the setting that allows the altimeter to read height above the aerodrome) is not available in Canada.

3.1.5 FLIGHT PRIORITY

Normally ATC provides Air Traffic Services on a *first come, first served* basis; ATC, however, gives priority to:

- a/ an aircraft that has declared an emergency;
- b/ an aircraft that appears to be in a state of emergency but is apparently unable to inform ATC;
- c/ an aircraft that reports it may be compelled to land because of factors, other than fuel shortage, affecting its safe operation;
- d/ an aircraft carrying, or proceeding to, a point to pick up a sick or seriously injured person requiring urgent medical attention. Priority over altitudes to be flown is given to an aircraft carrying a sick or seriously injured person if his or her condition requires it;
- e/ military aircraft departing on operational air defence flights or air defence exercises.

3.1.6 CLEARANCES AND INSTRUCTIONS

Whenever an Air Traffic Control "*clearance*" is received and accepted by the pilot, he or she shall comply with the clearance. If a clearance is not acceptable, the pilot should immediately inform ATC of this fact, because acknowledgement of the clearance alone is understood by the controller to indicate acceptance. For example, on receiving a



clearance for takeoff, the pilot should acknowledge it and take off without undue delay or, if not ready to take off at that particular time, inform ATC of intentions, in which case the clearance may be changed or cancelled. Inclusion of the word “*immediate*” in the clearance indicates that expeditious compliance is required.

A pilot shall comply with an Air Traffic Control “*instruction*”, provided the safety of the aircraft is not jeopardized.

A “*clearance*” is identified by some form of the word “clear”. An “*instruction*” is always worded in such a manner as to be readily identified, although the word “instruct” seldom is included, e.g., ALPHA BRAVO CHARLIE CALL ON FINAL RUNWAY 32.

Remember that control is predicated only on *known air traffic*. When complying with clearances or instructions, pilots are not relieved of the responsibility for practising good airmanship.

NOTE:

A clearance or instruction is only valid while in controlled airspace. Pilots transiting controlled and uncontrolled airspace should pay close attention to the terrain and obstacle clearance requirements.

**3.1.7
NOISE ABATEMENT RUNWAY ASSIGNMENT**

On occasion the assigned runway is not closest into the wind. This may be due to efforts to minimize flights over residential areas adjacent to the airport for noise abatement purposes. In this case, the choice is made according to the following consideration:

- a/ suitability of the *runway surface condition*;
- b/ effective *crosswind component* (max. 25 kts for arrivals and departures);
- c/ effective *tailwind component* (max. 5kts).

It remains the pilot’s responsibility to decide if the runway is acceptable for his aircraft. No pilot is required to use a runway that is not operationally suitable.

**3.1.8
RADAR**

A. GENERAL

Radar increases airspace use by allowing ATC to reduce the separation interval between aircraft. In addition, radar permits an expansion of services such as traffic information and radar navigation assistance, and provides information on chaff drops, bird activity and severe weather information. Due to limitations inherent in all radar systems, it may not always be possible to detect aircraft, weather disturbances, etc. Where radar service is provided by use of SSR without primary radar, it is not possible to provide traffic information on aircraft that are not transponder-equipped or to provide some of the other flight information mentioned above. Fig. 3-11 shows the extent of radar coverage in Canada.

B. SYSTEMS

Two types of radar are currently in use in Canada: *Primary Surveillance Radar (PSR)* and *Secondary Surveillance Radar (SSR)*. PSR is a radar that detects and reports reflections of aircraft, weather, flocks of birds, stationary objects, etc. that are within range of its sweep, approximately 80 NM. SSR is a radar that transmits an “interrogation beam” as it sweeps, to which an airplane transponder responds with Mode 3/A and or Mode 2 and (optionally) Mode C altitude data, with a 250 NM range.

The new radar system: RAMP (Radar Modernization Program), will provide much more accurate, reliable and expanded radar coverage. The system includes Terminal Surveillance Radar (TSR) and Independent Secondary Surveillance Radar (ISSR). TSR are systems with both PSR and SSR information, they are capable of digitizing primary radar targets including weather data for presentation. The ISSR systems will only provide SSR information.

Fig. 3-1 is a typical, though simplified, example of a controller’s radar display. Displayed is a terminal approach map and several targets.

The symbol used for each target is system determined and indicates the type of radar information on which the target is based. These can be PSR, SSR, either or both.

If a flight plan is available to the system which corresponds to the received SSR code, then a *data tag* will be produced and the target will be assigned to a specific sector. The sector allocation is indicated by the two letter designation directly above the target symbol.

In this case the data tag will have the IDENT of the aircraft, the weight category and language preference as line one of the tag. Line two will show the altitude and ground speed.

If no flight plan exists then the data tag will show only the SSR code, altitude and speed of the aircraft.

Other data represented in the diagram are sector boundaries, airways, transition fixes and reporting points.

The maps used by the controller are designed for each sector and have several overlays. These can contain other data, such as airways, fuel dump areas, military activity areas etc., which can be selected on or off as required.

C. PROCEDURES

Before providing radar service, ATC identifies the aircraft, either by using position reports, identifying turns, or transponders. ATC notifies pilots whenever radar identification is established or lost.

EXAMPLE:

RADAR IDENTIFIED, or RADAR IDENTIFICATION LOST.

Radar identification of flights does not relieve pilots of the responsibility to avoid terrain or uncontrolled aircraft. Workload and equipment capability permitting, Air Traffic Control provides traffic information to radar identified aircraft if the target appears likely to merge with another radar observed target.

Air Traffic Control *assumes responsibility for terrain clearance* when vectoring both en route IFR and IFR aircraft vectored for arrival until the aircraft is within the final approach area. Accepting a vector does not relieve a VFR aircraft from its responsibility for maintaining adequate obstacle clearance.

When necessary, ATC uses radar vectoring for

separation purposes, as required by noise abatement procedures or when the pilot requests it, or whenever vectoring offers operational advantages to the pilot or the controller. When ATC commences *vectoring*, the controller informs the pilot of the purpose for which the aircraft is being vectored and the fix, airway or point to which the aircraft is being vectored.

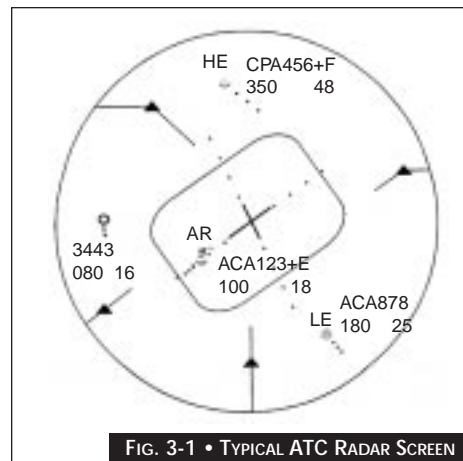

FIG. 3-1 • TYPICAL ATC RADAR SCREEN

EXAMPLES:

TURN LEFT HEADING 050 FOR VECTORS TO VICTOR 300.

MAINTAIN HEADING 200 FOR VECTORS TO THE VANCOUVER VOR 053 RADIAL

DEPART KLEINBURG BEACON ON HEADING 240 FOR VECTORS TO FINAL APPROACH COURSE.

ATC informs pilots when radar vectoring is terminated, except when an arriving IFR or CVFR aircraft has been cleared for an approach or an aircraft has been vectored to the traffic circuit.

EXAMPLE:

RADAR SERVICE TERMINATED.

D. OBSTACLE CLEARANCE DURING RADAR VECTORS

Normally, the pilot of an IFR flight must ensure that adequate clearance from obstacles and terrain, as specified in the *Air Regulations*, is maintained. When the flight is being radar-vectored, however, air traffic control ensures that the appropriate obstacle clearance is provided.

Minimum vectoring altitudes, which may be lower than minimum altitudes shown on navigation and approach charts, are established at a number of locations to facilitate transitions to instrument approach aids. When clearing an IFR flight to descend to the lower altitude, ATC provides terrain and obstacle clearance until the aircraft is in a position from which it can commence an approved instrument approach or a visual approach.

E. RADAR TRAFFIC INFORMATION

ATC provides IFR and VFR flights with information on observed radar targets whenever the traffic may be of concern to the pilot unless the service is precluded by higher priority duties, radar limitation, or omission is requested by the pilot. In Class C airspace, IFR and VFR traffic are provided with radar separation.

ATC attempts to provide radar separation between identified IFR aircraft and unknown observed aircraft in Class D airspace, workload and equipment permitting.

When issuing radar information, ATC normally defines the relative location of traffic, weather areas, etc., by using the “clock” position system. Although ATC gives clock position relative to the aircraft track, a pilot receiving this information may determine the approximate location of traffic, weather, etc., in relation to the aircraft heading which, regardless of direction, is always considered as 12 o'clock.

Traffic information, when passed to radar-identified aircraft, consists of:

- 1/ position of the traffic in relation to the aircraft;
- 2/ direction in which the traffic is proceeding;
- 3/ type of aircraft or the relative speed of the traffic;
- 4/ the altitude if known.

EXAMPLE:

TRAFFIC, 2 O’CLOCK 3 1/2 MILES, WESTBOUND at 6,000 FT, (type of aircraft and altitude, or relative speed).

An aircraft that is not radar-identified receives the following traffic information:

- 1/ position of the traffic in relation to a particular fix;
- 2/ direction in which the traffic is proceeding;
- 3/ type of aircraft or relative speed of the aircraft if known;
- 4/ the altitude if known.

EXAMPLE:

TRAFFIC, 7 MILES SOUTH OF QUEBEC NDB, NORTHBOUND SLOW MOVING, (type of aircraft and altitude, or relative speed).

F. SEVERE WEATHER INFORMATION

Radar-equipped ATC units often can provide information on the location and movement of areas of heavy precipitation and on severe weather conditions. During severe weather conditions, however, ATC can adjust the radar to eliminate or reduce radar returns from heavy precipitation areas to permit the detection of aircraft.

When requested by a pilot, and when traffic conditions permit, controllers provide detailed information on the location of heavy precipitation areas.

Pilots using on-board weather radar or storm scopes should request heading or track changes for weather avoidance from ATC as soon as possible prior to encountering the severe weather. This will result in less aircraft manoeuvring and will allow ATC more time to ensure separation. Specific headings or distances off track should be requested whenever possible (e.g. REQUEST DEVIATION 10 MILES SOUTH FOR WEATHER AVOIDANCE). When clear of the weather, advise ATC and state requested action.

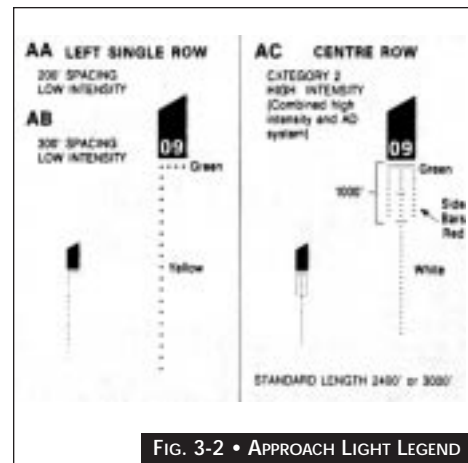

3.1.9 VISUAL GROUNDS AIDS

Visual ground aids are used for identification of the limits of runways, taxi ways and ramp areas. They also assist in landing and taxiing during VFR and IFR conditions both during the day and night. These aids can be classified into three main groups:

- a/ landing aids;
- b/ taxiing aids; and
- c/ aerodrome identification aids.

Landing aids must allow the aircraft to make safe contact with the touchdown area. They consist primarily of the approach lighting system and a type of glide path slope indicator system. *Runway markings* both on and near the runway give valuable orientation and roll-out information.

A. APPROACH LIGHTING SYSTEMS

These are visual aids used to supplement the guidance information of electronic aids such as VOR, TACAN, PAR and ILS. Lighting systems are intended to improve operational safety during the final approach and landing phase of flight. The approach lights are designated *low-intensity* (the basic type of installation) and *high-intensity*, according to candle-power output. (See Fig. 3-2).

Many runway and approach lighting systems' intensity can be adjusted by the tower or FSS to compensate for climatic conditions or time of day.

The approach lighting system currently in use at any given aerodrome can be found in the *Canada Air Pilot* approach plate, and the configuration appears on a legend sheet in the *CAP*.

1. **CATEGORY I AND II LIGHTING:** Category I lighting consists primarily of 2,400 to 3,000 feet of variable intensity lights with a white bar 1,000 feet and a red bar 300 feet back from the threshold, which has a green bar. This system is the primary installation for TCA and will be modified by the addition of a white bar with red barrettes, 500 feet back for Category II instrument flying. All Category II lighting systems are 3,000 feet in length.

2. **OTHER TYPES OF LIGHTING:** Other types of lighting used at civil aerodromes in Canada consist of single-row low-intensity lighting, either left of, or on the centre line, or double-row high-intensity lighting. At military aerodromes, a high-intensity Calvert system is normally used.

3. **STROBES:** Strobes are short-duration condenser discharge lights of 30 million candle-power or more, used to identify the active runway direction and as runway end identification lights.

The most important role of strobes is that of centre line approach markers to aid in locating the runway threshold during low-visibility conditions. The "lead-in" strobes are brilliant, fog-penetrating, high-intensity lights which flash sequentially toward the runway from a distance of 3,000 feet out.

Another use is that of runway identification to assist inbound aircraft in locating the

active runway while still some distance from the airfield. Many civil and military airfields have omnidirectional flashing strobes installed at each side of the threshold of the active runway aligned towards the approach zone. These lights act as threshold identification aids and are called *Runway End Identifier Lights (REIL)*.

4. **AIRCRAFT RADIO CONTROL AERODROME LIGHTING (ARCAL):** Aircraft radio control of aerodrome lighting systems are becoming more prevalent as a means of conserving energy especially at aerodromes which are

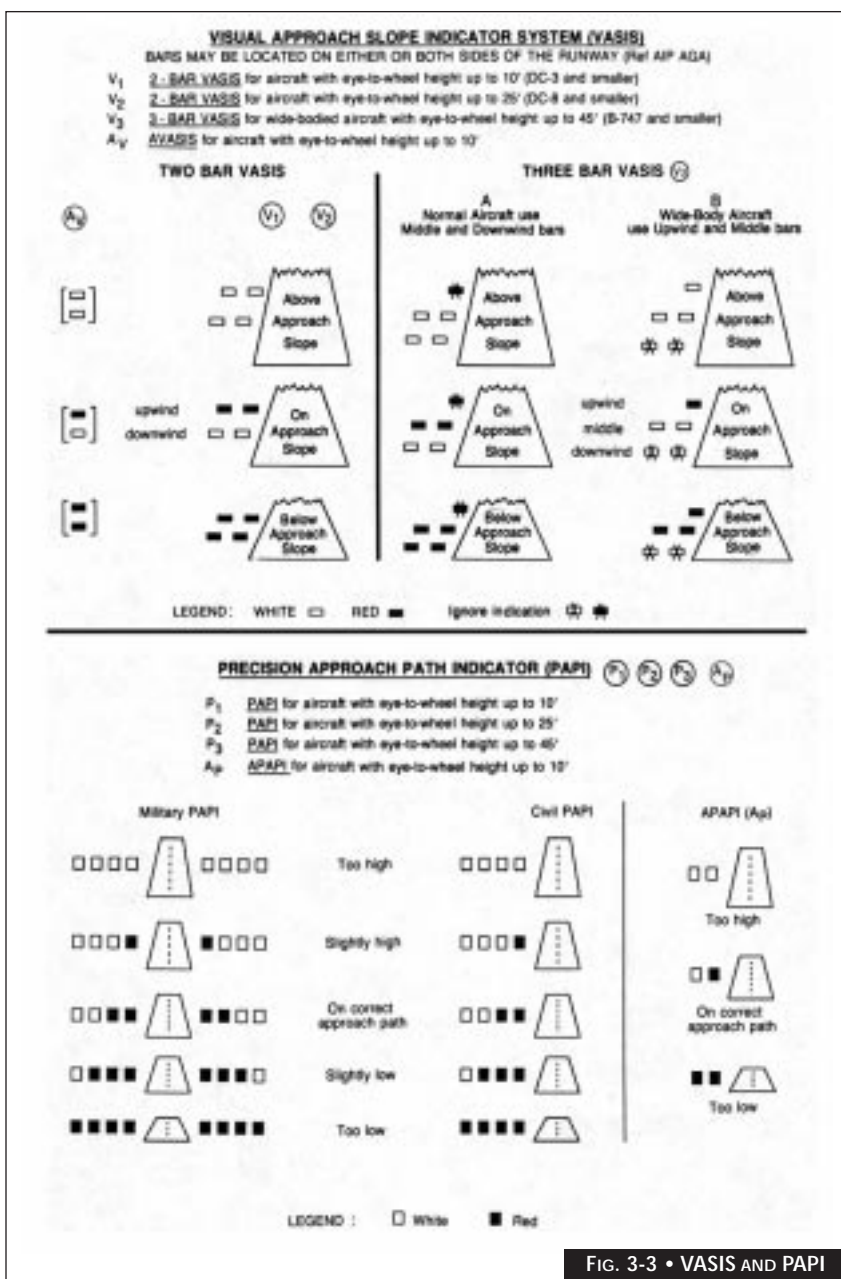

FIG. 3-3 • VASIS AND PAPI



not manned on a continuous basis or where it is not practicable to install a landline to a nearby FSS. All, or only portions of the aerodrome lighting may be controlled except for the rotating beacon and obstruction lights. They are generally activated by clicking the microphone a certain number of times within a prescribed time period.

B. VASIS - VISUAL APPROACH SLOPE INDICATOR SYSTEM

VASIS is a colour-coded visual approach aid which emits a lighted glide path within the final approach zone. It should have an angle and touch-down point coincident with any precision aid (ILS or PAR) serving the same runway. Under VFR conditions, VASIS is visible for approximately 5 miles by day and for more than 10 miles by night.

The standard VASIS is a two-bar system. A three-bar VASIS system is used to give a visual presentation for long-bodied aircraft. The upwind and middle bars are used by these aircraft; all others use the downwind and middle bars. Another type of VASIS is called PAPI - *Precision Approach Path Indicator*. It consists of four lights on the left side of the runway in the form of a bar.

INHERENT ERRORS:

- 1/ during approaches in low visibility or precipitation, erroneous glide path indications may occur from reflections/refraction of the light beams;
- 2/ visibility will be reduced in direct sunlight and with snow-covered backgrounds;
- 3/ system guidance may deteriorate close to the threshold because of spreading of the light sources;
- 4/ caution should be exercised where runway threshold lights are used in conjunction with VASIS. VASIS is an aid and should be cross-checked with all other variable aids.

NOTE:

Where VASIS is provided on a precision approach runway, unless specifically requested by the pilot, VASIS will be turned off in weather conditions of less than 500 ft ceiling and/or visibility less than one mile. This is to avoid possible contradiction between the precision approach and VASIS glide paths.

C. AERODROME MARKINGS

1. **ALL-WEATHER RUNWAY MARKINGS:** The markings to be found painted on the

runway surface in white reflective paint are:

- a/ runway direction number;
- b/ centre line;
- c/ threshold;
- d/ landing zone hatching; and
- e/ runway edge marking.

The markings in yellow reflective paint are:

- a/ the under-run, blast pad or relocated threshold markings;
- b/ obstructed or unsafe areas; and
- c/ stabilized shoulders or unstrengthened areas of the runway.

The *white markings* are generally informative and on the safe areas of the runway. *Yellow markings* are usually in the form of chevrons or hatchings and are danger areas which should not be used.

2. **TAXI-WAY MARKINGS:** Turning points for taxi exits are normally shown as yellow lines curving off from the runway centre line, which then becomes a taxi-way centre line. *Double blue lights* mark each turning point on the way to the ramp. On some aerodromes, amber lights or lighted arrows indicate the taxi exits. Where taxi-way systems are complex, lighted and reflective markers with arrows and taxi designators are employed.

Taxi-way edges are marked by yellow lines and blue lights as in the ramp area.

Green centre line taxi-way lighting is employed in some areas to mark active taxiways to and from the ramp area.

3. **RAMP MARKINGS:** Ramp area markings are placed in accordance with operational requirements and generally include safe taxi line, car and equipment safety lanes and danger areas.

Danger areas are normally painted in yellow hatching. Taxiing over these areas must be avoided. Yellow hatched barriers with flashing red or amber lights normally close off larger danger areas; red flags with flare pots mark the smaller ones.

Further information on aerodrome markings is available in *AIP Canada*.

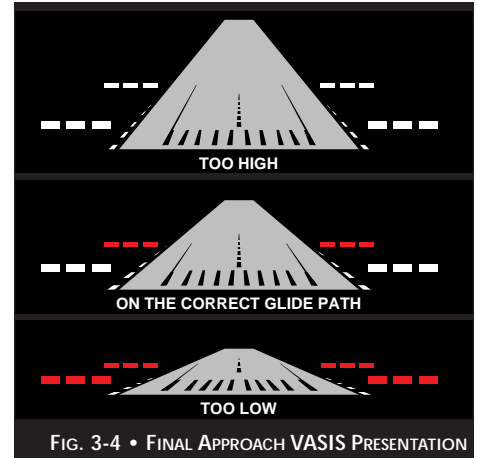

3.2 CANADIAN AIRSPACE

3.2.1 GENERAL

Canadian airspace is divided into a number of categories which in turn are sub-divided into a number of areas and zones. The various rules are simplified by the classification of all Canadian airspace. For convenience, a general description is provided here; however because of constant revision, *AIP Canada*, the *Designated Airspace Handbook*, *Canada Flight Supplement* or other appropriate publications should be consulted for more detail and to ensure information is current.

3.2.2 CANADIAN DOMESTIC AIRSPACE

Canadian Domestic Airspace (CDA) is divided into two geographic areas: - Northern Domestic Airspace and Southern Domestic Airspace (Fig. 3-5). In addition, the CDA is divided vertically into the *low level airspace* which consists of all the airspace below 18,000' ASL; and the *high level airspace* which consists of all airspace from 18,000' ASL and above.

A. NORTHERN DOMESTIC AIRSPACE (NDA)

The Magnetic North Pole is located near the centre of the NDA, therefore magnetic compass indications may be erratic. Thus, in this airspace, all track reference is in reference to true north and true track is used to determine cruising altitude for direction of flight in lieu of magnetic track. All of the NDA is within the *standard pressure region* (Fig. 3-9).

B. SOUTHERN DOMESTIC AIRSPACE (SDA)

In the SDA all track reference is in reference to magnetic north and magnetic track is used to determine cruising altitude for direction of flight. All high level airspace in the SDA is within the standard pressure region and all low level airspace is within the *altimeter setting region* (Fig. 3-9).

3.2.3 CONTROLLED AIRSPACE

Controlled airspace is the airspace within which air traffic control service is provided and within which some or all aircraft may be subject to air traffic control. Types of controlled airspaces are:

- a/ *IN THE HIGH LEVEL AIRSPACE:* The Southern, Northern and Arctic Control Areas;

NOTE:

Encompassed within the above are High Level Airways, Military Flying Areas, the upper portions of some Military Terminal Control Areas and Terminal Control Areas.

- b/ *IN THE LOW LEVEL AIRSPACE:*

- i/ Low Level Airways,
- ii/ Control Area Extensions,
- iii/ Terminal Control Areas,
- iv/ Control Zones,
- v/ Military Terminal Control Areas,
- vi/ Transition Areas.

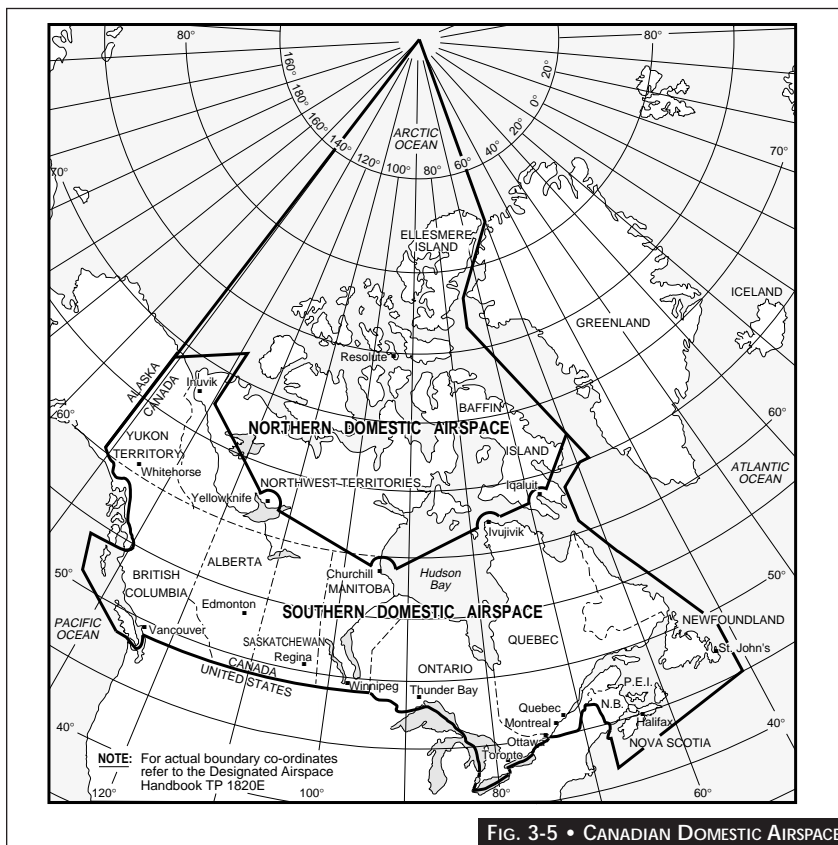

FIG. 3-5 • CANADIAN DOMESTIC AIRSPACE

A. HIGH LEVEL CONTROLLED AIRSPACE

Controlled airspace within the High Level Airspace is divided into three separate areas. They are the *Southern Control Area (SCA)*, the *Northern Control Area (NCA)*, and the *Arctic Control Area (ACA)*. Their lateral dimensions are illustrated in Fig. 3-6. Fig. 3-7 illustrates their vertical dimensions which are: SCA, 18,000' ASL and above; NCA, FL 230 and above; ACA, FL 280 and above.

Pilots are reminded that both the NCA and the ACA are within the Northern Domestic Airspace, therefore compass indications may be erratic and *true tracks* are used in determining the flight level at which to fly. In addition, the airspace from FL 330 to FL 390 within the lateral dimensions of the NCA, the ACA and the Northern part of the SCA has been designated CMNPS airspace. Special procedures apply within this airspace. See Article 3.2.8 or AIPRAC for details.

B. LOW LEVEL CONTROLLED AIRSPACE

1. *LOW LEVEL AIRWAYS*: Controlled Low Level Airspace extending upwards from 2,200' AGL up to, but not including 18,000' ASL, within the following specified boundaries:

i/ *LF/MF (NDB) airways* - the basic airway width is 4.34 NM on each side of the centre line prescribed for such an airway. Where applicable, the airway width shall be increased between the points where lines diverging 5° on each side of the centre line from the designated facility, intersect the basic width boundary and where they meet similar lines projected from the adjacent facility (Fig. 3-8);

ii/ *VHF/UHF (VOR) airways* - the basic airway width is 4 NM on each side of the centre line prescribed for such an airway. Where applicable, the airway width shall be increased between the points where lines, diverging 4.5° on each side of the centre line from the designated facility, intersect the basic width boundary and where they meet similar lines projected from the adjacent facility (Fig. 3-8).

2. *CONTROL AREA EXTENSIONS*: A control area extension is airspace that has been designated for one of the following purposes:

i/ to provide additional controlled airspace around busy aerodromes for IFR control. (The controlled airspace contained within the associated control zone and airway(s) width is not always sufficient to permit the manoeuvring required to separate IFR arrivals and departures);

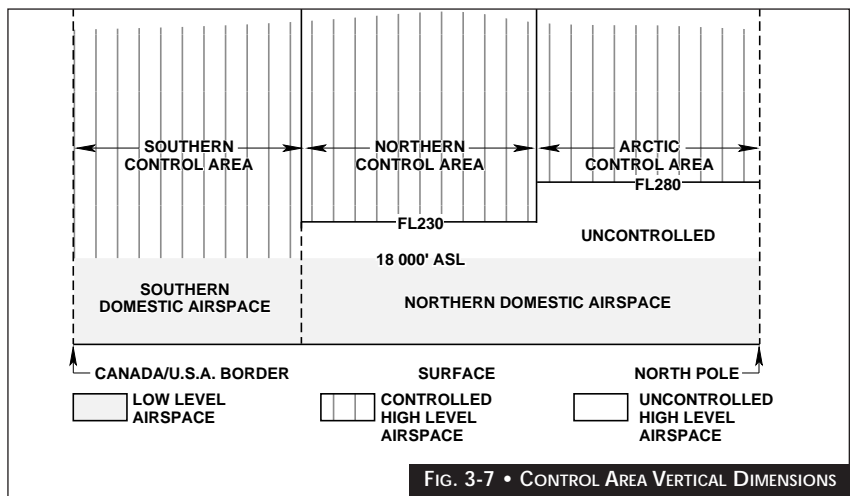

- ii/ to connect controlled airspace, such as the control area extensions that connect the domestic airways structure with the oceanic control areas.

Control area extensions are based at 2,200' AGL unless otherwise specified and extend up to, but not including, 18,000' ASL. Some control area extensions such as those which extend to the oceanic controlled airspace may be based at other altitudes such as 2,000', 5,500' or 6,000' ASL. The outer portions of some other control area extensions may be based at higher levels.

3. **TERMINAL CONTROL AREAS:** A terminal control area (TCA) is controlled airspace of defined lateral and vertical dimensions.

A terminal control area is similar to a control area extension except that:

- i/ a terminal control area may extend up into the high level airspace, and
- ii/ IFR traffic is normally controlled by a terminal control unit (TCU). (The ACC will control a TCA during periods when a TCU is shut down.)

A *military terminal control area (MTCA)* is the same as a terminal control area except that special provisions prevail for military aircraft while operating within the MTCA.

4. **CONTROL ZONES:** Control Zones have been designated around certain aerodromes to keep IFR aircraft within controlled airspace during approaches and to facilitate the control of VFR and IFR traffic. Control zones within which a radar control service is provided normally have a 7 mile radius. Others have a 5 mile radius with the exception of a few which have a 3 mile radius.

Control zones are capped at 3,000' above airport elevation unless otherwise specified. *Military control zones* usually have a 10 mile radius and are capped at 6,000' AGL. All control zones are depicted on the VFR aeronautical charts and the Low Altitude charts.

5. **TRANSITION AREAS:** Controlled airspace of defined dimensions extending upwards from 700' AGL unless otherwise specified,

to the base of overlying controlled airspace.

3.2.4 ALTIMETER SETTING REGION

The altimeter setting region is an airspace of defined dimensions below 18,000 feet ASL (Fig. 3-9) within which the following altimeter setting procedures apply:

DEPARTURE: Prior to take-off, the pilot shall set the aircraft altimeter to the current altimeter setting of that aerodrome or, if that altimeter setting is not available, to the elevation of the aerodrome.

EN ROUTE: During flight the altimeter shall be set to the current altimeter setting of the nearest station along the route of flight or, where such stations are separated by more than 150 NM, the nearest station to the route of flight.

ARRIVAL: When approaching the aerodrome of intended landing, the altimeter shall be set to the current aerodrome altimeter setting, if available.

3.2.5 STANDARD PRESSURE REGION

The standard pressure region includes all airspace over Canada at or above 18,000 feet ASL (the high level airspace), and all low level airspace that is outside of the lateral limits of the altimeter setting region (Fig. 3-9). Within the standard pressure region the following flight procedures apply:

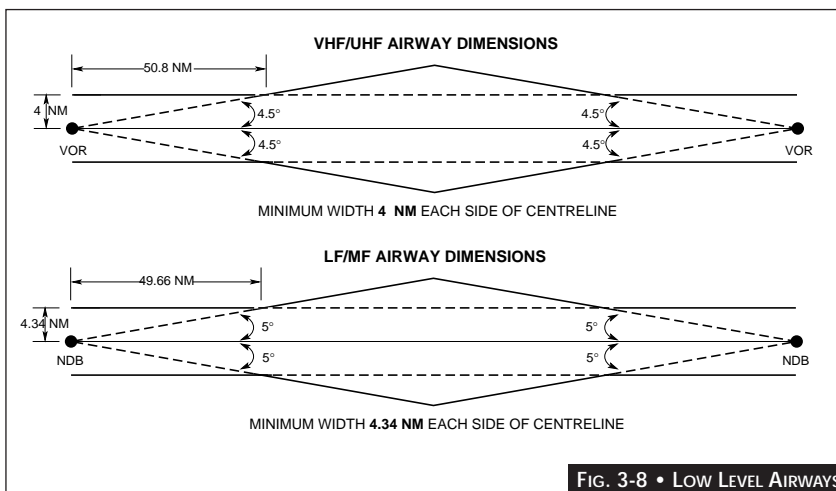

FIG. 3-8 • LOW LEVEL AIRWAYS

GENERAL: Except as otherwise indicated below, no person shall operate an aircraft within the standard pressure region unless the aircraft altimeter is set to standard pressure, which is 29.92" HG or 1013.2 MBs. (See Note).

DEPARTURE: Prior to take-off, the pilot shall set the aircraft altimeter to the current altimeter setting of that aerodrome or, if the altimeter setting is not available, to the elevation of that aerodrome. Immediately prior to reaching the flight level at which flight is to be maintained, or passing 18,000 feet if the cruising altitude is above FL 180, the altimeter shall be set to standard pressure (29.92" HG or 1013.2 MBS).

ARRIVAL: Prior to commencing descent with the intention to land, the altimeter shall be set to the current altimeter setting of the aerodrome of intended landing, if available. However, if a holding procedure is conducted, the altimeter shall not be set to the current aerodrome altimeter setting until immediately prior to descending below the lowest flight level at which the holding procedure is conducted.

TRANSITION: Except as authorized by ATC, aircraft progressing from one region to another would make the change in the altimeter setting while within the standard pressure region prior to entering, or after leaving, the altimeter setting region. If the transition is to be made into the altimeter setting region while in level cruising flight, the pilot should obtain the current altimeter setting from the nearest station along the route of flight as far as practical before reaching the point at which the transition is to be made. When climbing from the altimeter setting region into the standard pressure region, pilots should set their altimeters to standard pressure

(29.92" HG or 1013.2 MB) immediately after entering the standard pressure region. When descending into the altimeter setting region, pilots shall set their altimeters to the approach station altimeter setting *immediately prior* to descending into the altimeter setting region. Normally, the pilot will receive the appropriate



altimeter setting as part of the ATC clearance prior to descent. If it is not incorporated in the clearance, it should be requested by the pilot.

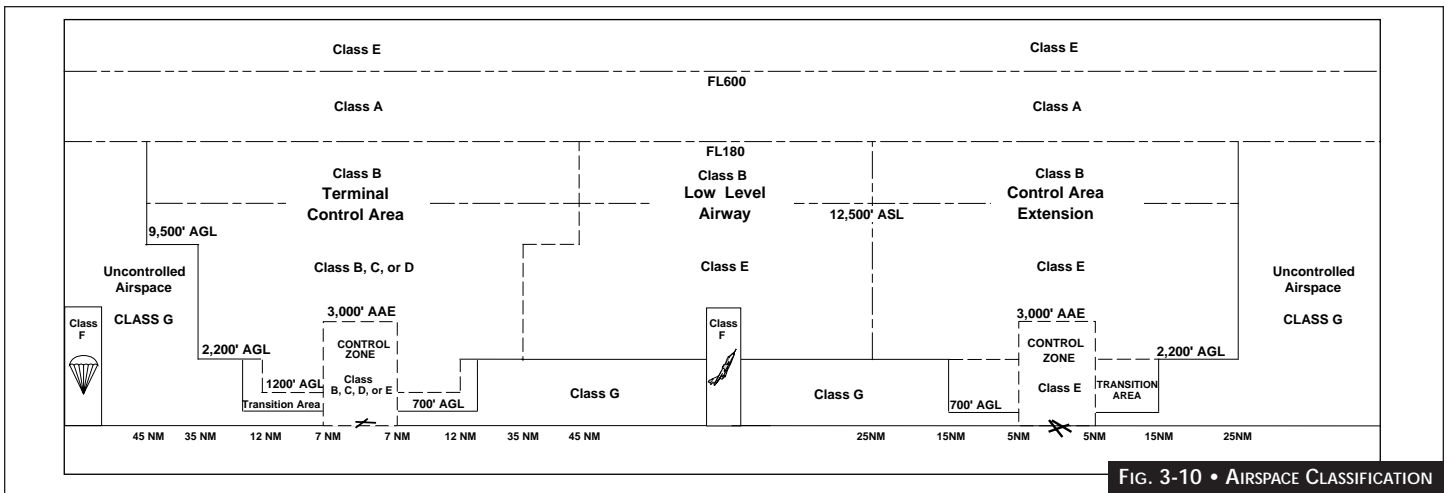

NOTE:

When an aircraft is operating in the standard pressure region with standard pressure set on the altimeter sub scale, the term “flight level” is used in lieu of “altitude” to express its height. Flight level is always expressed in hundreds of feet. For example, flight level 250 (FL250) represents an altimeter indication of 25,000 feet; flight level 50, an indication of 5,000 feet.

3.2.6

CLASSIFICATION OF AIRSPACE

Canadian Domestic Airspace is divided into *seven classes*, each identified by a single letter - A, B, C, D, E, F or G (**Fig. 3-10**). Flight within each class is governed by specific rules applicable to that class and are contained in the *Air Regulations*.

The rules for operating within a particular portion of airspace depends on the classification of that airspace and not on the name by which it is commonly known. Thus, the rules for flight within a high level airway, a terminal control area or a control zone depend on the class of airspace within all or part of those areas. *Weather minima* are specified for controlled or uncontrolled airspace, not for each class of airspace.

The following is a brief description of the rules for each class of airspace:

CLASS A: All operations must be conducted under instrument flight rules (IFR) and are subject to ATC clearances and instructions. ATC separation is provided to all aircraft.

Class A airspace is designated from the base of all high level controlled airspace up to and including FL600.

CLASS B: Operations may be conducted under IFR or VFR. All aircraft are subject to ATC clearances and instructions. ATC separation is provided to all aircraft.

All low level controlled airspace above 12,500’ ASL up to but not including 18,000’ ASL is Class B airspace. Control zones and associated terminal control areas may also be classified as Class B airspace.

CLASS C: Operations may be conducted under IFR or VFR. ATC separation is provided to all aircraft operating under IFR and, as necessary, to VFR aircraft when an IFR aircraft is involved.

All VFR operations will be provided with traffic advisories and upon request, conflict resolution instructions.

VFR traffic requires an ATC clearance to enter.

Terminal control areas and associated control zones may be classified as Class C airspace.

CLASS D: Operations may be conducted IFR or VFR. ATC separation is provided only to aircraft operating under IFR. All traffic will receive traffic advisories, and upon request, conflict resolution may be provided, equipment and workload permitting.

VFR traffic must establish two-way communications prior to entry. ATC may instruct VFR traffic to remain clear of the Class D airspace.

A terminal control area and associated control zone could be classified as Class D airspace.

CLASS E: Operations may be conducted under IFR or VFR. ATC separation is provided only to aircraft operating under IFR. There are no special requirements; low level airways, control area extensions, transition areas, or control zones established without an operating control tower may be classified as Class E airspace.

CLASS F: Airspace may be classified as:

- a/ *Advisory Airspace* if it is airspace within which an activity occurs of which non-participating pilots should be aware (e.g., training areas, parachute areas, hang gliding areas, etc.);
- b/ *Restricted Airspace* if:
 - 1/ it is airspace within which an activity occurs which is dangerous to aircraft operations (i.e., firing ranges, rocket ranges, etc.); or
 - 2/ it is airspace from which aircraft must be excluded for security reasons (e.g., Royal, Heads of State or Papal visits, penitentiaries, etc.); or
 - 3/ its use would promote the efficient flow of air traffic at selected airports.

NOTE:

Although not designated as Class F airspace, operations within a given area may also be restricted under the Aeronautics Act to cover specific



situations such as a forest fire or disaster area. These areas are published by NOTAM when required.

CLASS G: Operations may be conducted under IFR or VFR. ATC has neither the authority or the responsibility for exercising control over air traffic. ATIS will, however, provide flight information and alerting services as required.

All airspace which has not been designated A, B, C, D, E or F will be classified as Class G *uncontrolled airspace*.

3.2.7

SPECIAL USE AIRSPACE

A. GENERAL

Under certain conditions it is considered necessary to limit flying in specified Canadian airspace. Special use airspace may be classified as *advisory* or *restricted*. Operations in Class F *advisory* airspace are allowed but pilots are encouraged to exercise caution.

Information concerning such airspace and the nature of the limitations may be found in the following documents and directives:

- 1/ Regulations concerning flight restrictions into national, provincial and municipal parks;
- 2/ *Designated Airspace Handbook*, Part 9, "Class F Airspace";
- 3/ NOTAM - temporary restrictions to flight are normally covered by NOTAM action, e.g. airspace reservations, etc.;
- 4/ Information circulars entitled "General" or the *AIP*.

In general, flight may be permitted subject to prior approval within Class F *restricted* airspace. If approved, it is undertaken at the pilot's discretion. This applies to both IFR and VFR aircraft.

B. MILITARY OPERATIONS AREAS (MOA)

Pilots flying within the high-level structure should take into account published military operations areas when planning their route of flight. These are *reserved* for military training and testing exercises and normally *other aircraft are not permitted to operate within these areas*.

When operational requirements permit, the military may release specified portions of a MFA to ATC to accommodate transiting aircraft. However, this should be considered the exception rather than the rule and pilots should plan their route of flight to avoid these areas. MOAs are depicted on the *High Altitude En route Charts*, and are defined in the *Designated Airspace Handbook*.

C. MILITARY ACTIVITY AREAS (MAA)

A military activity area is a defined block of airspace approved for intensive military flying during a specified time. It normally includes both controlled and uncontrolled airspace in a stationary area or an area moving in relation to the flight of the aircraft within.

The airspace and time period involved are published by NOTAM, normally at least 24 hours in advance, except when there is insufficient time for NOTAM action.

When in uncontrolled airspace, pilots should remain clear of these areas, particularly if operating in IFR weather conditions. Air Traffic Control treats any controlled airspace in a military activity area as an airspace reservation.

D. DANGER AREAS

A danger area is a defined block of airspace within which activities dangerous to flight, such as artillery firing and aerial gunnery, may occur at specified times. Pilots may enter danger areas at their own discretion. Due to the obvious hazard in these areas, however, pilots are strongly *urged to avoid them* during active periods. Pilots of aircraft operating under IFR are not cleared into active danger areas.

E. RESTRICTED AIRSPACE

Restricted airspace is a defined block of airspace within which flight is restricted according to certain specified conditions.

IFR flights will not be cleared through active restricted areas unless the pilot states that permission has been obtained.

F. ADVISORY AIRSPACE

Advisory airspace is a defined block of airspace in which a high volume of pilot training or unusual aerial activity, such as parachuting or

soaring, is carried out. The aerial activity in advisory airspace is conducted according to VFR flight rules. While pilots of non-participating flights may enter at their own discretion, they are urged to avoid these areas during designated active periods, or be exceptionally vigilant while within them. Pilots of aircraft operating under IFR are not cleared into active advisory airspace.

G. ALTITUDE RESERVATIONS

This is a block of controlled airspace reserved for the use of an agency during a specified time. Information on the airspace and time period involved normally are published by NOTAM.

For ease of reference, certain military air refuelling areas recurring at the same location in controlled airspace are depicted on High Altitude En route Charts and in the *Canada Flight Supplement*. When active, these areas constitute airspace reservations.

Pilots should plan to avoid known altitude reservations. Air Traffic Control does not clear an unauthorized flight into an active reservation. IFR flights operating within controlled airspace and certain VFR flights are provided with standard separation from reserved airspace.

H. ROCKET RANGES

Rocket ranges are established near Churchill, Manitoba, and are depicted on VFR aeronautical charts and radio navigation charts and have been designated restricted areas. The particular range to be active, and the time period involved, is published in advance in NOTAM.

NOTE:

Pilots may enter rocket ranges at their own discretion. Due to the obvious hazard, however, pilots are strongly urged to avoid them during active periods. Pilots of aircraft operating under IFR are not cleared into active rocket ranges.

3.2.8 CANADIAN MINIMUM NAVIGATION PERFORMANCE SPECIFICATIONS AIRSPACE (CMNPS)

To allow maximum utilization of airspace and to safely and efficiently accommodate the

volume and concentration of domestic and international air traffic transiting the Arctic Control Area, the Northern Control Area, and parts of the Southern Control Area, Canadian Minimum Navigation Performance Specifications Airspace (Fig. 3-11) has been established between FL 330 and FL 390.

Reduced lateral and longitudinal separation between aircraft operating in CMNPS Airspace can be accommodated by specifying minimum aircraft navigation equipment for operating within this airspace. *Only aircraft certified as meeting CMNPS* are permitted to operate within the designated CMNPS Airspace unless ATC can accommodate an aircraft without penalizing CMNPS certified aircraft.

To provide safe, efficient transition between CMNPS Airspace and the domestic airways structure, a reduction in the Canadian domestic lateral separation minimum is authorized. The *transition area* in which this reduced separation may be applied is FL280 to below FL330 within the horizontal boundaries of CMNPS Airspace.

More detailed information on CMNPS may be found in *AIP Canada RAC*.

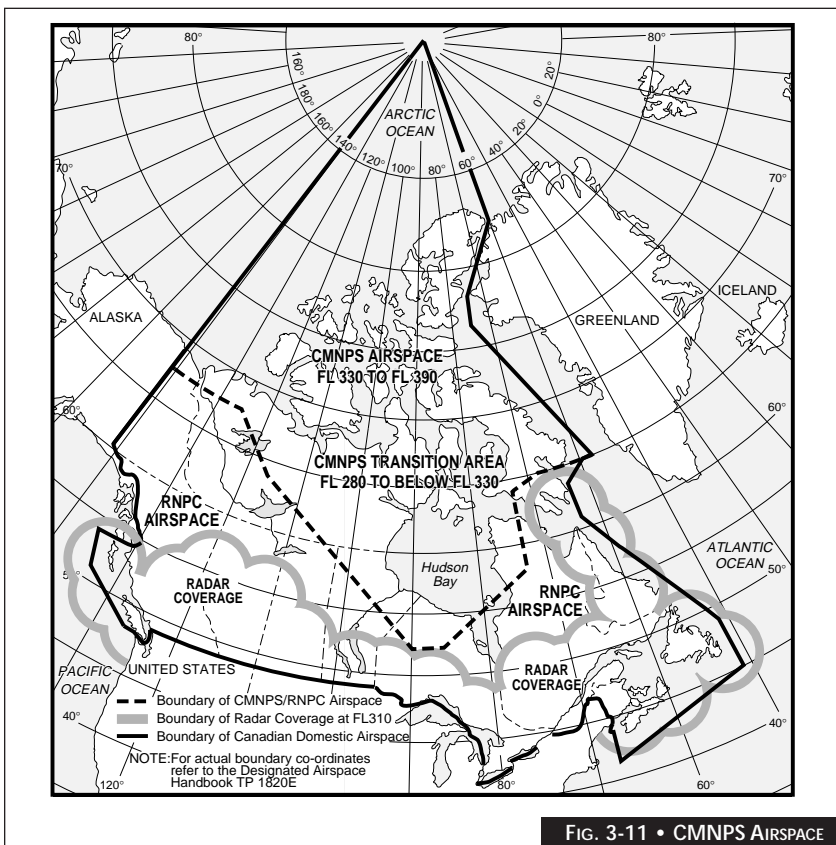

FIG. 3-11 • CMNPS AIRSPACE

REQUIRED NAVIGATION PERFORMANCE CAPABILITY (RNPC) AIRSPACE

The airspace that has been designated for RNAV operations is referred to as RNPC airspace which is controlled airspace within the lateral limits of the area of southern Canada depicted in Fig. 3-11. To flight plan published high level fixed RNAV routes, or random RNAV routes, (See Fig. 2-96) or to be accommodated by ATC on other routes using RNPC separation criteria, aircraft must be certified as being capable of navigating within specified tolerances.

The minimum navigation equipment likely to satisfy the RNPC is one long range area navigation system plus VOR/DME and ADF.

3.2.9 NORTH ATLANTIC MNPS AIRSPACE

At the ninth Air Navigation Conference of ICAO, the concept of Minimum Navigation Performance Specifications (MNPS) was adopted on a world-wide basis. This has the objective of ensuring safe separation of aircraft and *at the same time* enabling operators to derive maximum accuracy of navigation equipment demonstrated in recent years.

By 1980, the minimum lateral separation between aircraft which meet the MNPS and which operate in the NAT MNPSA became 60 NM.

An implicit condition of the concept of MNPS is that all operators must maintain the specified operating standards and be aware of the inherent obligations of the requirement.

NAT MNPS guidance material is contained in the *North Atlantic MNPS Airspace Operations Manual* which is published on behalf of the NAT Systems Planning Group. Operators should be familiar with the contents of the Document which can be obtained from ICAO in Montreal. See *AIP Canada* for details.

Compliance with the MNPS is required by all aircraft operating on routes within the following defined airspace boundaries:

- a/ between FL275 and FL400;
- b/ between latitudes 27° and the North Pole;
- c/ in the East, the Eastern boundaries of CTAs Santa-Maria Oceanic, Shanwick Oceanic and Reykjavik; and

- d/ in the West, the Western boundaries of CTAs Reykjavik and Gander Oceanic and New York Oceanic excluding the area west of 69°W and south of 38°30'N.

Aircraft used to conduct flights within the volume of airspace specified in the preceding paragraph, shall have specified navigation performance capability.

Such navigation performance capability shall be verified by the State of the Operator as appropriate. Transport Canada is responsible for authorizing all Canadian civilian registered aircraft to fly within NAT MNPS.

Navigation equipment likely to meet NAT MNPS are:

- a/ dual Inertial Navigation System (INS/IRS);
- b/ dual OMEGA Navigation System (ONS); or
- c/ single INS/IRS plus ONS.

GPS may be used to replace one of the navigation systems listed above. Fig. 3-12 shows the boundaries of NAT MNPS airspace.

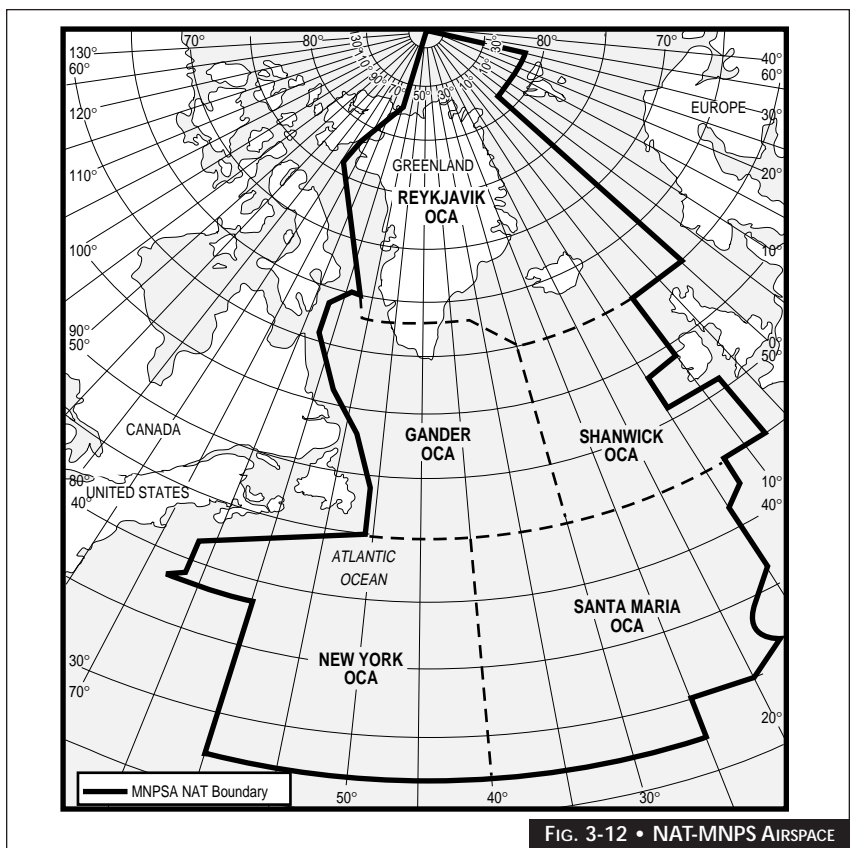

3.3 IFR SEPARATION

3.3.1 GENERAL

This section acquaints pilots with the basic non-radar methods of control used by ATC. With this understanding, pilots can draw up flight plans more effectively, and comply with ATC clearances more readily.

3.3.2 VERTICAL SEPARATION

A. MINIMA AND PROCEDURES

Air Traffic Control provides *vertical separation* by requiring aircraft to operate at different assigned altitudes. The separation is based on the following minima: FL 290 and below - 1,000 ft.; above FL 290 - 2,000 ft.

B. SEPARATION BETWEEN FLIGHT LEVELS AND ALTITUDES ASL

When the altimeter setting is less than 29.92" there is less than 1,000 ft vertical separation between an aircraft flying at 17,000 ft ASL on the altimeter setting and an aircraft flying at FL 180. Therefore, based on this example, the lowest usable flight level is assigned or approved according to the following table:

IF THE ALTIMETER SETTING IS	THEN THE LOWER USABLE FLIGHT LEVEL IS
29.92 OR HIGHER	FL 180
29.91 TO 28.92	FL 190
28.91 TO 27.92	FL 200
27.91 OR LOWER	FL 210

3.3.3 LONGITUDINAL SEPARATION

A. MINIMA AND PROCEDURES

Air traffic control applies *longitudinal separation* expressed in units of time so that after one aircraft passes over a position a following aircraft at the same altitude does not, on the basis of a control

estimate, arrive over the same position within less the appropriate minimum number of minutes. They apply longitudinal separation expressed in miles based on position reports, through Direct Controller-Pilot Communication (DCPC), from concerned aircraft in relation to a DME facility.

Air Traffic Control establishes longitudinal separation by clearing aircraft:

- 1/ to depart at a specified time;
- 2/ to arrive over a specified fix at a specified time (phraseology - ARRANGE YOUR FLIGHT TO ARRIVE OVER (reporting point) NOT BEFORE/LATER THAN (time));
- 3/ to hold at a fix until a specified time; or
- 4/ to reverse heading.

Air Traffic Control may request two aircraft to maintain a specified longitudinal separation between each other provided that the aircraft are in direct communication with each other, and are using NAVAIDS that permit determination of position and speed at intervals not exceeding 40 minutes flying time.

B. PHRASEOLOGY

MAINTAIN AT LEAST (number miles/minutes separation) FROM (aircraft identification).

3.3.4 LATERAL SEPARATION

A. GENERAL

Air Traffic Control provides *lateral separation* of IFR flights in the form of "airspace to be protected", relating to a holding procedure, instrument approach procedure or the approved track.

The dimensions of protected airspace selected for a particular track take into account the accuracy of available ground-based NAVAIDS, which provide track guidance; accuracy of airborne receiver and indicator equipment; a pilotage tolerance each side of the indicated track; and a small allowance for sudden wind shift. Therefore, it is essential that the accuracy capability of navigation equipment be maintained, and the pilots of IFR or controlled

VFR flights adhere as closely as practicable to the centerline of approved tracks (Fig. 3-13).

Because of the quality of navigation signal coverage and communications facilities available, pilots should plan their flights along *designated airways* (unless using RNAV routes) whenever practicable. For track segments within signal coverage of NDB or VOR stations, protected airspace takes into account the accuracy of available track guidance, accuracy of airborne receiver and indicator equipment and pilotage tolerance. Separation exists as long as the airspaces provided for each aircraft do not overlap.

Normally the allocation of airspace for an approved track assumes that the changeover from one navigation reference to another occurs approximately midway between facilities. Where this is not possible due to a difference in the signal coverage provided by two adjacent NAVAIDs, the *equal-signal point* on an airway segment is shown on the IFR en route chart.

To remain clear of Class F Advisory or Restricted airspace, pilots should prepare flight plans so that the airspace to be protected for their intended tracks does not overlap the area of concern. Pilots realizing that they are outside the airspace protected for their approved tracks should notify the appropriate ATC unit immediately.

B. CONTROLLED AIRSPACE

ATC protects the following airspace along approved tracks:

1/ 4 miles each side of centerline to a distance of 51 miles from a VOR and then within lines that diverge at 4.5 degrees from a VOR until they meet similar lines from the adjacent VOR for:

- i/ airway segments based on VOR; or
- ii/ off airway tracks that are within signal coverage of a VOR;

2/ 4.34 miles each side of centerline to a distance of 50 miles from an NDB and then within lines that diverge at 5 degrees from an NDB until they meet similar lines drawn from the adjacent NDB for:

- i/ airway segments that are based on NDBs; or
- ii/ off airway tracks that are within signal coverage of an NDB (Fig. 3-14); or
- iii/ airspace to be protected for airway segments which are served by a VOR at one end and a NDB at the other is determined as if the whole segment is based on NDBs;

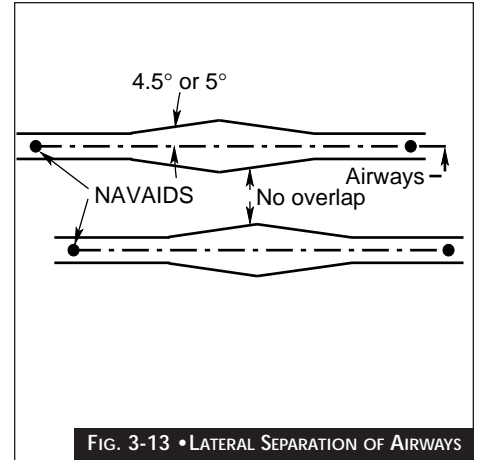

FIG. 3-13 • LATERAL SEPARATION OF AIRWAYS

3/ 45 miles each side of centerline for tracks that are beyond signal coverage or are not based on NAVAIDs (Fig. 3-15).

C. CHANGE OF DIRECTION AT AND ABOVE FL 180

Air Traffic Control protects additional airspace at and above FL 180 on the manoeuvring side of tracks which change direction by more than 15° at a NAVAID or intersection (Fig. 3-17).

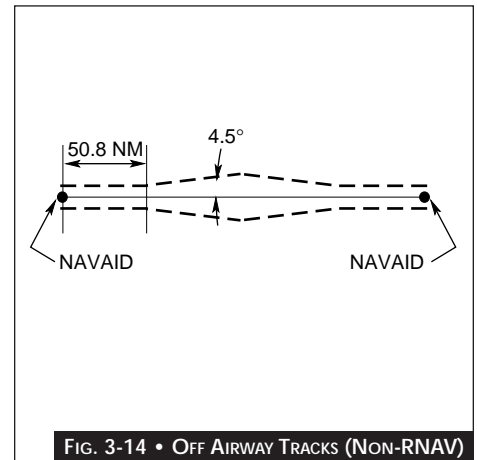

FIG. 3-14 • OFF AIRWAY TRACKS (NON-RNAV)

Pilots operating below FL 180 should make turns so as to remain within the normal width of airways or airspace protected for off-airway tracks.

Since the lateral separation minima applied by ATC depend on the probable accuracy of navigation along each track, it is the pilot's responsibility to remain within the boundaries of protected airspace for an assigned track to be assured of lateral separation from other air traffic.

D. LATERAL PROTECTED AIRSPACE FOR IFR INSTRUMENT APPROACH PROCEDURES (LOW ALTITUDE)

Increased air traffic requires more definitive standards to assure separation between IFR flights. For example, the need exists to define

further the minimum geographical spacing needed to separate aircraft conducting approaches simultaneously at adjacent airports. Also, there is a need to define precisely the geographical spacing between an aircraft conducting an approved standard instrument approach procedure and adjacent aircraft holding or en route.

Accordingly, air traffic controllers are authorized to use the basic horizontal "obstacle clearance" dimensions of intermediate approach areas, final approach areas and missed approach areas, as the "airspace to be protected" for aircraft conducting standard instrument approach procedures. (See Fig. 4-24). Adequate horizontal separation exists when the "airspace to be protected" for such aircraft does not overlap "airspace being protected" for aircraft en route, holding or conducting simultaneous adjacent instrument approaches.

3.3.5 WAKE TURBULENCE SEPARATION

In Canada, aircraft groups are:

GROUP 1 (HEAVY): all aircraft certified for maximum take-off weight of 300,000 lbs or more;

GROUP 2 (MEDIUM): aircraft certified for a maximum take-off weight of between 12,500 and 300,000 lbs;

GROUP 3 (LIGHT) - aircraft certified for a take-off weight up to 12,500 lbs inclusive.

Controllers apply the following radar minima between a preceding IFR/VFR aircraft and an aircraft vectored directly behind it at altitudes less than 1,000 ft below:

HEAVY BEHIND A HEAVY	4 NM
MEDIUM BEHIND A HEAVY	5 NM
LIGHT BEHIND A HEAVY	6 NM
LIGHT BEHIND A MEDIUM	4 NM

For *non-radar departures*, the minima are two (2) minutes for any aircraft behind a heavy if

the aircraft concerned commences the take off from the threshold of the same runway or a parallel runway that is located less than 2,500 feet away. This also applies where the aircraft use crossing runways and where projected flight paths will cross.

NOTES:

1. A light aircraft following a medium aircraft will be issued a wake turbulence cautionary in the situation described above.
2. B757 are considered heavy aircraft owing to their strong wake turbulence characteristics.

These minima are extended to three (3) minutes for any aircraft that departs in the wake of a known heavy aircraft, or a light aircraft that takes off into the wake of a known medium aircraft if:

- a/ the following aircraft starts its take-off roll from an intersection or a point significantly further along the runway, in the direction of take-off, than the preceding aircraft; or
- b/ the controller has reason to believe that rotation may occur beyond the rotation point of the preceding aircraft.

In spite of these measures, ATC cannot guarantee that wake turbulence will not be encountered.

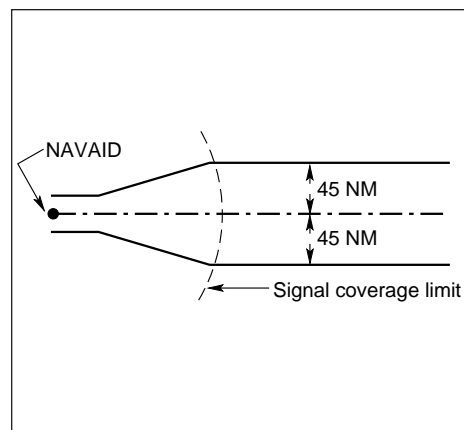

FIG. 3-15 • TRACKS ON HIGH-LEVEL VOR AIRWAYS

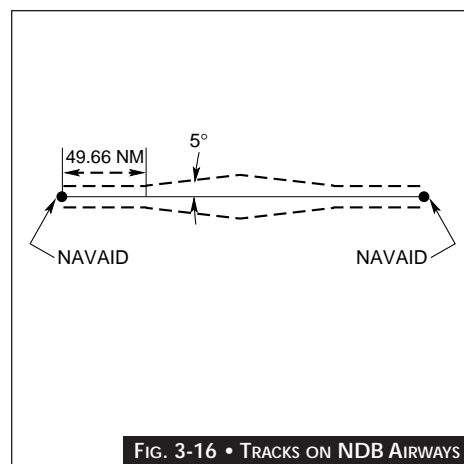

FIG. 3-16 • TRACKS ON NDB AIRWAYS

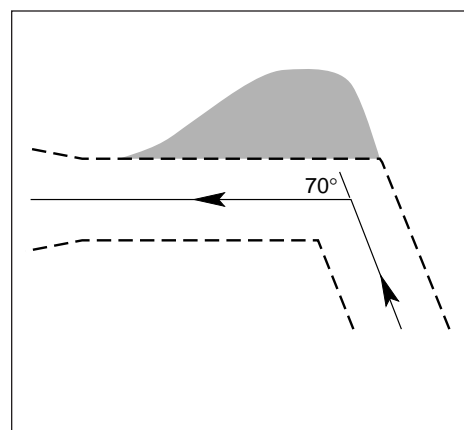

FIG. 3-17 • HIGH LEVEL TRACKS - CHANGE OF DIRECTION



3.4 RADIO PROCEDURES

3.4.1 BASIC RADIO PROCEDURES

A. GENERAL

Pilots should:

- 1/ deliver radio messages *clearly and concisely* - use only acceptable phraseology and enunciate precisely;
- 2/ *plan the content* of the message to be transmitted before pressing the "transmit" button;
- 3/ precede every transmission with a brief but careful *listening-out period* to avoid interference with other transmissions.

B. RADIOTELEPHONY CONTACT

This generally consists of four parts: call-up, reply, the message, and the acknowledgement or ending. In all examples, the words enclosed within parentheses may be omitted.

EXAMPLE:

Call-up by aircraft:

ROBERVAL RADIO (THIS IS) CESSNA CITATION FOXTROT ALPHA BRAVO CHARLIE

Reply by ground station:

CESSNA CITATION FOXTROT ALPHA BRAVO CHARLIE (THIS IS) ROBERVAL RADIO, GO AHEAD.

The message - Aircraft:

FOXTROT ALPHA BRAVO CHARLIE FOUR MILES SOUTH THROUGH SIX THOUSAND LANDING ROBERVAL - CLEARED FOR LOCALIZER/DME RUNWAY THREE FOUR ESTIMATING AT ONE FIVE.

Flight Service Station:

ALFA BRAVO CHARLIE ACTIVE RUNWAY THREE FOUR WIND THREE SIX ZERO AT ONE FIVE ALTIMETER TWO NINER NINER SEVEN TRAFFIC PIPER AZTEC DEPARTING RUNWAY THREE FOUR SOUTHBOUND REPORT BY THE INTERMEDIATE FIX.

Acknowledgement - Aircraft:

TWO NINER NINER SEVEN ALFA BRAVO CHARLIE

The pilot should note that:

On the initial call-up and reply, both the aircraft and the ground station use the four-letter aircraft call sign.

When contact is established, ATS may employ an abbreviated call sign (three-letter).

The aircraft repeats the altimeter setting, acknowledges receipt of information and terminates the contact by transmitting its abbreviated call sign.

The pilot should always monitor a selected frequency before transmitting and should not transmit until the frequency is clear.

C. MESSAGE ACKNOWLEDGEMENT

A pilot shall acknowledge the receipt of all ATC messages directed to and received by him or her. Such acknowledgement may take the form of a transmission of the aircraft call sign, a repeat of the clearance with the aircraft call sign or the call sign followed by an appropriate word(s).

EXAMPLES:

ATC: VICTOR LIMA CHARLIE CLEARED TO LAND

Pilot: VICTOR LIMA CHARLIE

ATC: VICTOR LIMA CHARLIE ARE YOU AT FIVE THOUSAND?

Pilot: VICTOR LIMA CHARLIE AFFIRMATIVE

NOTE:

Clicking of the microphone button as a form of acknowledgement is not acceptable radio procedure.

D. READABILITY SCALE AND COMMUNICATION CHECKS

The readability scale uses the figures 1 to 5, meaning:

- 1/ unreadable;
- 2/ readable now and then;
- 3/ readable with difficulty;
- 4/ readable;
- 5/ perfectly readable.

The main types of communications checks are:

- 1/ *signal check*, made while the aircraft is airborne;
- 2/ *pre-flight check*, made prior to departure;
- 3/ *maintenance check*, made by ground maintenance personnel.

EXAMPLE:

NAME RADIO (this is) CESSNA FOXTROT ALFA BRAVO CHARLIE - SIGNAL CHECK ON FIVE SIX EIGHT ZERO. CESSNA FOXTROT ALFA BRAVO CHARLIE (This is) (name) RADIO - READ YOU FIVE.

S	...	SIERRA	(SEE-AIR-RAH)
T	-	TANGO	(TANG-GO)
U	..-	UNIFORM	(YOU-NEE-FORM)
			OR
			(OO-NEE-FORM)
V	...-	VICTOR	(VIK-TAH)
W	.—	WHISKEY	(WISS-KEY)
X	...-	X-RAY	(ECKS-RAY)
Y	-.—	YANKEE	(YANG-KEY)
Z	—..	ZULU	(ZOO-LOO)
0	— — -	ZERO	
1	. — —	WUN	
2	.. — -	TOO	
3	... —	TREE	
4 -	FOW-ER	
5	FIFE	
6	-	SIX	
7	— ...	SEVEN	
8	— - .	AIT	
9	— — .	NIN-ER	

3.4.2

RADIOTELEPHONE COMMUNICATIONS

A. ICAO INTERNATIONAL PHONETIC ALPHABET/MORSE CODE

Pilots should memorize this standard information or have a copy handy to assist in identifying NAVAIDS.

A	..	ALFA	(AL-FAH)
B	BRAVO	(BRA-VOH)
C	CHARLIE	(CHAR-LEE) (OR SHAR-LEE)
D	DELTA	(DELL-TAH)
E	ECHO	(ECK-OH)
F	FOXTROT	(FOKS-TROT)
G	— . . .	GOLF	(GOLF)
H	HOTEL	(HOH-TEL)
I	INDIA	(IN-DEE-AH)
J	. — - .	JULIETT	(JEW-LEE-ETT)
K	KILO	(KEY-LOH)
L	LIMA	(LEE-MAH)
M	— . . .	MIKE	(MIKE)
N	NOVEMBER	(NO-VEM-BER)
O	— — . .	OSCAR	(OSS-CAH)
P	. — . .	PAPA	(PAH-PAH)
Q	— . . .	QUEBEC	(KEH-BECK)
R	ROMEO	(ROW-ME-OH)

Phonetic letter equivalents should be used for single letters or to spell out groups of letters or words whenever considered necessary to ensure understanding. Pilots must use phonetics for registration letters in aircraft call signs on initial contact.

B. AIRCRAFT CALL SIGNS

On *initial contact* with ATS, pilots of Canadian private aircraft shall use the manufacturer's name or type of aircraft followed by the last four characters of the registration in phonetics.

EXAMPLE:

CESSNA GOLF CHARLIE FOXTROT ECHO

Pilots shall include the word HEAVY if applicable. (A heavy jet is one that can have a take-off weight of 300,000 lbs or more.)

When initiated by ATS, subsequent aircraft identification (for aircraft using their civil registration) may be abbreviated to the last three characters of the registration.

EXAMPLE:

CHARLIE FOXTROT ECHO

The word HEAVY can be omitted when no likelihood of confusion exists.

C. GROUND STATION CALL SIGNS

These comprise the name of the airport followed by the type of station.

EXAMPLES:

CALGARY TOWER (airport control tower)

HALIFAX GROUND (ground control position in tower)

KINGSTON RADIO (flight service station)

MIRABEL CLEARANCE DELIVERY (IFR clearance delivery position)

OTTAWA TERMINAL (Terminal Control Position)

VANCOUVER ARRIVAL (Arrival Control Position)

EDMONTON DEPARTURE (Departure Control Position)

MONTREAL CENTRE (Area Control Centre)

D. NUMBERS

In general, numbers except whole thousands should be transmitted by pronouncing each digit separately.

EXAMPLES:

75 SEVEN FIVE

100 ONE ZERO ZERO

576 FIVE SEVEN SIX

11000 ONE ONE THOUSAND

Exceptions are described as follows:

Altitude above sea level may be expressed in thousands plus hundreds of feet. Separate digits should be used to express flight levels.

EXAMPLES:

2800 TWO THOUSAND EIGHT HUNDRED

14500 ONE FOUR THOUSAND FIVE HUNDRED

FL265 FLIGHT LEVEL TWO SIX FIVE

FL200 FLIGHT LEVEL TWO ZERO ZERO

Aircraft identification, flight number, aircraft type numbers, wind speed and cloud height may be expressed in group form.

EXAMPLES:

AC320 AIR CANADA THREE TWENTY

DC10 DC TEN

WIND 270/10 WIND TWO SEVEN ZERO AT TEN

M 35 BKN MEASURED THIRTY FIVE HUNDRED BROKEN

Aircraft headings are given in groups of three digits, expressed in degrees magnetic except in the area of compass unreliability where heading is expressed in degrees true. The words degrees and magnetic are omitted with reference to magnetic heading while the word true follows the numbers when true heading is used. HEADING 360 is used to signify a north heading.

EXAMPLES:

005 HEADING ZERO ZERO FIVE

350 HEADING THREE FIVE ZERO

E. DECIMAL POINTS

Decimal points are indicated by the word DECIMAL. However, when VHF or UHF frequencies are specified, the DECIMAL may be omitted if no misunderstanding is likely to occur.

3.4.3 COMMUNICATIONS PROCEDURES AT UNCONTROLLED AERODROMES

A. GENERAL CONSIDERATIONS

An uncontrolled aerodrome is an aerodrome without a control tower in operation. Many aerodromes have towers that operate only part-time; these are uncontrolled aerodromes during the period when the tower is not operating.

Aircraft operations on, or in the vicinity of,

uncontrolled aerodromes can present problems, some of which have the potential for conflict. Without air and ground traffic control, hazardous situations can develop if there is inadequate exchange of information about the movement of aircraft and aerodrome maintenance equipment. Safety can be increased if pilots *report their position and intentions* in an orderly way, and monitor a common radio frequency while operating within a prescribed distance of uncontrolled aerodromes.

The *operation of vehicles* on runways is essential to maintain aerodromes in a safe operational status. Consequently, information concerning a pilot's landing or take-off intentions must be conveyed to aerodrome authorities so that the vehicles can leave the appropriate runways. At aerodromes served by public air-ground communications stations, these facilities coordinate vehicle activity. However, they must be aware of aircraft activity to do an effective job. Flight Service Stations provide a vehicle control service (VCS) in conjunction with airport advisory service (AAS).

Some uncontrolled aerodromes are served indirectly by an FSS through *remote communication outlets (RCO)*. These outlets primarily are established for en route communications purposes, but a few also provide remote AAS and remote VCS. Where this capability exists, the remote FSS will coordinate removal of vehicles from the runway. Pilots must remember that the Flight Service Specialist is some distance away and cannot see what is going on. The Flight Service Specialist can only pass on information that has been given by radio.

A Flight Service Specialist can provide information on other aircraft only when advised of their presence and intentions. The specialist may not be aware of NORDO aircraft, or even of some radio-equipped aircraft operating in the vicinity, unless the pilots have advised of their activities.

B. ESTABLISHMENT OF MANDATORY FREQUENCIES

Transport Canada has designated a Mandatory Frequency (MF) for use at selected uncontrolled aerodromes or aerodromes that are controlled

between certain hours. Aircraft operating within the area in which MF is applicable, on the ground or in the air, shall be equipped with a functioning radio capable of maintaining two-way communication and specified procedures shall be followed.

Normally MF will only be designated at aerodromes served by an FSS, a CARS or an RCO, and the MF will normally be the frequency of the ground station which provides the advisory service and the vehicle control service for the aerodrome. For those aerodromes that have a designated MF, the specific frequency, distance and altitude within which MF procedures are to be followed will be published in the *CFS*:

MF - Arpt rdo 122.1 5NM 3035 ASL

C. AERODROME TRAFFIC FREQUENCY (ATF)

An ATF is normally designated for active, uncontrolled aerodromes listed in the *CFS* that do not meet the criteria for MF. The ATF is established to ensure that all radio-equipped aircraft operating on the ground or within the specified area are listening on a common frequency and following common reporting procedures. The ATF will normally be the frequency of the ground station where one exists or 123.2 MHz where a ground station does not exist. The specific frequency, distance and altitude within which use of the ATF is required will be published in the *CFS*.

ATF - tfc advsry 118.2 06-14Z 3NM 6900 ASL

D. USE OF THE MF AND ATF

There is no substitute for keeping a good lookout while flying in visual weather conditions; this is particularly true in the vicinity of uncontrolled aerodromes. The effective use of radio, however, can greatly increase flight safety.

All pilots operating radio-equipped aircraft at uncontrolled aerodromes for which a MF or ATF has been published must transmit position reports on the MF or ATF according to the procedures outlined in the following subsections.

Position reports have two formats; either a



directed transmission, made to a ground station or vehicle operator, or a *broadcast* (transmission) made to advise all concerned of the pilot's intentions. Wherever the MF or ATF is operated by a ground station, the initial transmission should be directed to the station.

Should there be no acknowledgement of a directed transmission, then pilots should make transmissions in the broadcast format unless the ground station subsequently establishes two-way contact, in which case pilots shall resume communicating by directed transmission.

Where no ground station exists, all reports shall be broadcast blind.

EXAMPLES:

Directed -

MUSKOKA RADIO - FXYZ IS 5 MILES NORTH OF THE MUSKOKA BEACON AT 3,000 FT. FOR LANDING RUNWAY 18 AT MUSKOKA. GO AHEAD YOUR ADVISORY.

OR

Broadcast -

MUSKOKA TRAFFIC - FXYZ IS 5 MILES NORTH OF THE MUSKOKA BEACON AT 3,000 FT. -PLANNING TO CROSS OVERHEAD TO JOIN THE CIRCUIT FOR RUNWAY 18. ETA IN 3 MINUTES.

E. IFR ARRIVAL PROCEDURES AT UNCONTROLLED AIRPORTS

The pilot-in-command of an IFR aircraft intending to conduct an approach at an uncontrolled aerodrome shall, unless otherwise instructed by ATC, transmit directed or broadcast position reports:

- 1/ *five minutes* before the estimated time of commencing the approach procedure, including in this report approach intentions and estimated time of landing;
- 2/ *upon passing the fix* with the intention of conducting a procedure turn, or, if no procedure turn is intended, upon first interception of the final approach track;
- 3/ *upon passing the Final Approach Fix* during

the final approach or three minutes before the estimated time of landing where no Final Approach Fix exists (approach facility on the aerodrome);

- 4/ *upon commencing a circling* procedure advising intentions;
- 5/ *when turning onto the final approach* leg advise position; and
- 6/ *in the event of a missed approach*, as soon as practical after commencing the missed approach, including in this report a statement of intentions.

In some cases, ATC will instruct the pilot to remain on a control frequency rather than transferring the pilot to the MF. When there is an FSS or RCO, ATC will advise the FSS of the delay and an estimated position of the aircraft. At other locations where there is no communications link between the ATS unit and the operator of the MF, ATS will transfer communications as soon as possible.

F. IFR DEPARTURE PROCEDURES AT UNCONTROLLED AERODROMES

A pilot intending to take off from an uncontrolled aerodrome shall:

- 1/ *obtain an ATC clearance* if in controlled airspace;
- 2/ report on the appropriate frequency the *departure procedure and intentions* before moving on to the runway or before aligning the aircraft on the take-off path; and
- 3/ ascertain by radio on the appropriate frequency and by visual observation that *no other aircraft or vehicle is likely to come into conflict* with the aircraft during take-off.

The pilot-in-command shall maintain a *listening watch*:

- 1/ *during take-off* from an uncontrolled aerodrome; and
- 2/ *after take-off* from an uncontrolled aerodrome for which a mandatory frequency has been designated, until the

aircraft is beyond the distance or above the altitude associated with that frequency.

As soon as possible after reaching the distance or altitude associated with the MF, the pilot-in-command shall communicate with the appropriate air traffic control unit or a ground station on the appropriate en route frequency. Where IFR departures are required to contact an IFR control unit or ground station after take-off, it is recommended that, if the aircraft is equipped with two radios, the pilot should also monitor the MF during the departure.

If the aerodrome is located in uncontrolled airspace, the above procedures shall be followed except that an ATC clearance is not required. In addition to maintaining a listening watch as outlined above, it is recommended that the pilot-in-command communicate with the appropriate air traffic control unit, FSS or other ground station on the appropriate en route frequency.

G. IFR PROCEDURES AT UNCONTROLLED AERODROMES IN UNCONTROLLED AIRSPACE

Whenever practical, pilots operating IFR in uncontrolled airspace should monitor 126.7 MHz and broadcast their intentions on this frequency immediately before changing altitude or commencing an approach. When arriving at aerodromes where the MF or ATF is another frequency, therefore, the pilot should broadcast *descent and approach intentions* on 126.7 MHz before changing to the MF or ATF. If conflicting IFR traffic becomes evident, this change should be delayed until the conflict is resolved.

Pilots departing IFR shall broadcast intentions on 126.7 MHz in addition to the MF or ATF before take-off. Pilots should monitor 126.7 MHz along with the MF or ATF if the aircraft has dual VHF radios.

**3.4.4
 INTERNATIONAL AIR-GROUND
 COMMUNICATIONS**

A. TYPES OF EMISSION

Both the HF single and double sideband modes of operation are available at Gander, Iqaluit,

Churchill and Cambridge Bay on the ICAO families of frequencies. ICAO VHF frequencies are also available at designated FSS. Gander also broadcasts weather for selected Canadian airports twice each hour. For details, pilots should refer to the appropriate station listings found in the *Canada Flight Supplement*.

B. SELECTIVE CALL SYSTEM (SELCAL)

This system is installed for use on international frequencies at Canadian stations. Pilots should check the remarks column in the station listings. SELCAL improves ground-to-air communication techniques by providing an automatic and selective method of calling an aircraft. Voice calling is replaced by the transmission of code tones to the aircraft over the international radiotelephony channels. A single call is a combination of four pre-selected audio tones requiring approximately two seconds transmission time. These tones are generated in the ground station coder and received by a decoder connected to the audio output of the airborne receiver. Receipt of the assigned tone code (SELCAL code) activates a light and/or chime signal in the cockpit.

The pilot is responsible for ensuring that the appropriate ground stations are advised of the SELCAL code available in the airborne equipment. The pilot may do this on the ICAO flight plan and when transferring in flight from one agency to another.



PART
FOUR

NOTES:

- 1/ The procedures and services described in Part 4 are under constant revision. Material in *AIP Canada* should be closely monitored since the *AIP* takes precedence over this material should a conflict of information occur.
- 2/ The reader should have access to the *Canada Flight Supplement*, *CAP East or West*, and en route and terminal charts while reading this part. All approach plates and charts found in this part are for training purposes only and must not be used operationally.

IFR FLIGHT PROCEDURES

- 4.1 FLIGHT PLANNING
- 4.2 DEPARTURE PROCEDURES
- 4.3 EN ROUTE PROCEDURES
- 4.4 HOLDING PROCEDURES
- 4.5 ARRIVAL PROCEDURES
- 4.6 INSTRUMENT APPROACH PROCEDURES
- 4.7 EMERGENCIES
- 4.8 TRANSPONDER OPERATION



Part 4 builds on the information presented earlier on instruments, navigation systems, basic attitude instrument flying and Air Traffic Services and follows the sequence of a normal IFR flight. It begins with flight planning and includes departure, en route, holding, arrival and instrument approach procedures. Sections on emergencies and transponder operation are found at the end of this part. More detailed information on some areas of this part can be found in *AIP Canada*.

4.1 FLIGHT PLANNING

4.1.1 REQUIREMENT TO FILE A FLIGHT PLAN

Prior to each flight pilots should file a flight plan or notification. IFR flight requires that a flight plan be filed.

Pilots must file a VFR or IFR flight plan prior to conducting any flight between Canada and the United States. If the flight is to any country other than the USA, the pilot must file an ICAO flight plan. (Copies of a Transport Canada and an ICAO flight plan are included in this section as Fig. 4-1 and 4-2).

The *Air Regulations* require that “prior to taking-off from any point within and prior to entering any controlled airspace during IFR flight, or during IFR weather conditions, a flight plan containing such information as may be specified by the Minister shall be submitted to the appropriate air traffic control unit”.

When communications facilities are inadequate to permit contact with ATC or an FSS, IFR flight conducted wholly outside of controlled airspace may be undertaken after a *flight itinerary* is submitted to a responsible person.

Prompt filing of IFR flight plans with air traffic control is essential. It allows control personnel time to extract and record the relevant content, correlate this new data with available information on other controlled traffic, and determine how the flight may best be coordinated with other traffic. To assist ATC in improving its service and to allow sufficient time for input into the ATC data processing

system, pilots must file IFR flight plans as early as practicable, preferably *30 minutes* before the proposed departure time. They must be prepared to depart as closely as possible to this proposed departure time. Before transborder flights where the point of departure is close to the boundary, pilots should file flight plans at least *one hour* in advance to facilitate adequate co-ordination and data transfer. Compliance with this procedure minimizes departure delays.

4.1.2 PURPOSES OF FLIGHT PLANNING

The IFR flight plan primarily enables ATS to fit an aircraft into the traffic system with minimum delay, and according to the pilot’s requested route and altitude. The flight plan contains all the operational information necessary for ATS to satisfy the pilot’s requirements during departure, while en-route and during the approach. Air Traffic Services, however, is not always able to meet every parameter in the flight plan; for example, the departure route may be altered if it conflicts with the main traffic flow.

Other reasons for flight planning are:

- a/ to serve as a safeguard in case of communication failure, allowing both the pilot and the controller to know exactly where the aircraft is going;
- b/ to assist in case of forced landing; permitting the aircraft’s most probable position to be assessed quickly;
- c/ to aid in statistical purposes, where IFR flight strips are registered and used for Transport Canada long-range planning; and
- d/ there is a legal requirement to file an IFR flight plan.

4.1.3 GENERAL CONSIDERATIONS IN FLIGHT PLANNING

There are several items that the pilot should consider for safety and convenience when flight planning. (It is assumed that the aircraft equipment meets the requirements for IFR flight, and that fuel and oil are adequate for the proposed trip.)

First the pilot should study the *weather*, including ceiling and visibility at the departure airport, destination airport, alternate airports and airports to be overflown during the flight. Cloud type and amount, turbulence and icing are also important in selecting an altitude. To plan effectively, the pilot should also know the wind velocity en route and the forecast at the destination and alternate.

Next, the *route* should be selected. The planning section of the *Canada Flight Supplement* should first be consulted to determine if there is a *preferred IFR route* established for the planned flight. At most major terminals in Canada, arriving and departing traffic is channelled into main arrival and departure routes through radar vectoring and/or assignment of preferential routes. If the pilot plans a route that goes against the main arrival flow, ATS may have to clear the aircraft via some other airway.

A second consideration in selecting an airway is the minimum en route altitude (MEA). For example, between Sudbury and Sault Ste. Marie, V-348 has an MEA of 7,000 ft while V-316 can be flown at 5,000 ft. The lower MEA along V-316 offers greater flexibility in choosing appropriate altitudes when icing is forecast, and it is only 1 mile longer than the other route.

The wind velocity at the destination and alternate should be checked against the forecast ceiling at the appropriate airports, particularly those with only one straight-in approach or with only one runway. It seems pointless to proceed to Wabush when the wind will exceed the crosswind component specified for the aircraft.

With good flight planning the pilot seldom should have to proceed to an alternate destination. When a pilot needs an alternate because the destination weather has deteriorated, he or she needs it badly - therefore it should be selected carefully. The first consideration is the availability of approach procedures to more than one runway. If these are precision approaches, so much the better.

Alternate "limits" are published in *Canada Air Pilot (CAP)* for flight planning purposes only. Once airborne, the limits for the alternate airport are the limits shown in the minima box of the approach chart. The pilot should check

the alternate if the weather at the destination is deteriorating. As a guide, if the weather is going down to near circling limits, the pilots should file another alternate right away, either as the primary or secondary choice, and make sure that ATS is advised.

NOTE:

Some airports in CAP have authorized alternate limits based on area forecasts because of the lack of terminal weather forecasting at those locations.

Once satisfied that the trip is on, the pilot should check for applicable NOTAMS, then fill in the Flight Plan Form. Appropriate publications must be carried on the aircraft - *CFS*, *CAP* and en route and terminal area charts.

**4.1.4
IFR FLIGHT PLAN FORM**

Flight plans, required for all IFR flights, should be filed at least 30 minutes before the estimated time of departure to avoid traffic delays. It is recommended that pilots inform ATC if a flight will not be commenced within 60 minutes of the proposed departure time stipulated in an IFR flight plan. Failure to do so may result in activating the Search and Rescue process or a delay caused by having to file another flight plan. At *uncontrolled airports*, pilots are responsible for closing the IFR flight plan unless advised otherwise by ATS. The flight plan (Fig. 4-1) should contain:

- a/ type of flight plan (IFR);
- b/ aircraft identification, including the full identification number of the aircraft;
- c/ aircraft type and equipment, i.e., the appropriate suffix for type of transponder, distance measuring equipment available on the aircraft, inertial navigation system, etc.;
- d/ true airspeed, given in knots and based on the estimated true airspeed at the planned flight altitude;
- e/ point of departure, identifier or name of the departure airport - however, if the flight plan is filed in the air, the point of departure is the position at which the flight plan is filed;

- f/ departure time, i.e., Coordinated Universal Time (Zulu);
- g/ initial cruising altitude, which must conform to appropriate cruising altitudes for the direction of flight;
- h/ route of flight;

NOTE:

If any segment of the flight is off-airways, the word "direct" (DRCT) should be entered. Any ground-based navigational aids listed in conjunction with the direct route automatically become reporting points. For other flights, the pilot should enter the navigational aids or airways to be used.

- i/ destination, i.e., the name of the airport or identifier;
- j/ remarks section (optional), which may include passengers' names, customs requirements or other non-operational information;
- k/ estimated time en route - the total time in hours and minutes, estimated from take-off until the aircraft is over the terminal facility;
- l/ fuel onboard - the time in hours and minutes which the fuel supply will last;
- m/ alternate airport, which must be entered in case weather prevents a landing at the destination;
- n/ Nav and Approach aids are indicated by placing digits in the appropriate boxes;
- o/ ELT manufacturer and model number should be entered in the ELT block;
- p/ pilot's name and licence number;
- q/ name and address of aircraft owner;
- r/ the number of persons onboard, required only if the flight is international, but advisable if the correct number of passengers is known;
- s/ aircraft colour (recommended), with the major colour entered first, followed by the trim colours.

Pilots should remember that, upon landing, the IFR flight plan is closed automatically if the airport has an operating control tower. *If the airport does not have a control tower, the pilot is responsible for closing the flight plan.*

**4.1.5
ICAO FLIGHT PLAN FORM**

Flight plans for international flights originating in, or entering Canada shall be filed in the ICAO format (Fig. 4-2). For the purpose of flight planning, flights between Canada and the Continental United States are not classed as international flights. Directions for completion of the ICAO flight plan form may be found in AIPRAC.

**4.1.6
IFR FUEL REQUIREMENTS**

The pilot in command is responsible for ensuring that there is enough fuel for the flight to be completed to the destination and thereafter to a suitable alternate destination.

PART - PARTIE 1 - PILOTS - PILOTES				
Air File / Plan déposé en vol	Type of flight - Régime de vol / NOTE	Aircraft identification / Immatriculation de l'aéronef	Type of aircraft & equipment / Type de l'aéronef et équipement	True air speed (Knots)/Mach / Vitesse vraie (nœuds)/Mach
<input type="checkbox"/>	<input checked="" type="checkbox"/> IFR <input type="checkbox"/> VFR <input type="checkbox"/> DVFR <input type="checkbox"/> AVIS	C-FLZA	C550/SDR/P	360
Point of departure - Point de départ		Flight altitude/level and route (if DVFR include altitude) - Altitude ou niveau de vol et route (Si DVFR indiquer l'altitude)		
CYOW		FL330 V300 YJN J500		
Destination Aerodrome / Aérodrôme de destination				
CYGM				
Time of Departure - Heure de départ (UTC)		Est. elapsed time / Durée totale est.	Alt. airport(s) / Aéroport(s) de dégagement	Fuel on board / Carburant embarqué
Proposed - Prévus	Actual - Réelle	Hrs Mins		Hrs Mins
1430		1 20	CYFC	4 00
Communication equipment / Équipement de communication		Navigational & Approach Aids / Aides à la navigation et à l'atterrissage		Total number of persons on board / Nombre total des personnes à bord
VHF	UHF	Other - Autres	ILS VOR ADF INS FMS GPS DME	Other - Autres
<input checked="" type="checkbox"/>	<input type="checkbox"/>	<input type="checkbox"/>	<input checked="" type="checkbox"/> <input checked="" type="checkbox"/> <input checked="" type="checkbox"/> <input type="checkbox"/> <input type="checkbox"/> <input type="checkbox"/> <input type="checkbox"/>	<input type="checkbox"/>
Name and address of aircraft owner / (Person(s) or company to be notified if search and rescue action initiated) / Nom et adresse du propriétaire de l'aéronef / (Personne(s) ou compagnie à aviser si des recherches sont entreprises)		Pilot's name - Nom du pilote		
TRANSPORT LTD, 751-100 ^e RUE, OTTAWA, ONT		C. PILON		
Other information (such as colour of aircraft etc.) - Autres renseignements (tels que couleur de l'aéronef, etc.)		SAR Time - Heure du SAR		
ROUGE ET BLANC				
An arrival report will be filed (Note - place, date, time, method) with - Un avis d'arrivée sera notifié (Avis - lieu, date, heure et méthode) à:				
ADCSU	Number of U.S. Citizens / Nombre de ressortissants américains	Other - Autres	Pilot's Licence No. - N° de licence du pilote	Pilot's Signature - Signature du pilote
<input type="checkbox"/>			A203030	C. Pilon
PART - PARTIE 2				
Flight plan (Note) received by - Plan de vol (Avis) reçu par		Flight plan (Note) passed to - Plan de vol (Avis) communiqué à		Received by - Reçu par

Fig. 4-1 • DOMESTIC IFR FLIGHT PLAN

The fuel supply should also accommodate any anticipated delays by ATS. There should be an appropriate fuel reserve for flight at normal cruise power settings, normally 45 minutes. (Refer to *Air Regulations* for more details).

- i/ T.A.S.;
- ii/ number of persons on board;
- iii/ location where an arrival report will be filed.

The pilot of a flight for which a flight plan has been filed shall report the arrival time to an ATC unit or communications base as soon as possible after landing.

A pilot may *cancel the IFR flight plan or change to a VFR flight plan* provided the aircraft is operating in VFR weather conditions, and is outside Class A or B airspace. Where conditions permit the remainder of a flight to be conducted in accordance with VFR, and the

4.1.7
CHANGES TO THE FLIGHT PLAN

Aircraft operating IFR must advise ATC and obtain a new or amended clearance before changing the following in the flight plan:

- a/ cruising altitude;
- b/ tracking;
- c/ destination aerodrome;
- d/ true airspeed at cruising altitude or flight level, where the change is more than 5% of the true airspeed specified in the flight plan;
- e/ Mach number, where the change is larger than .01 and the Mach number has been included in the ATC clearance.

IFR aircraft operating outside of controlled airspace are required to explain by broadcasting on the appropriate frequencies any changes in the items a - c above.

Consecutive IFR flight plans involving intermediate stops en route may be filed at the initial point of departure so long as the following points are adhered to:

- a/ the initial point of departure and en route stops must be in Canada;
- b/ the sequence of stops will fall within one consecutive 24-hr period; and
- c/ the flight planning unit must be provided at least these items for each stage of the flight:
 - 1/ point of departure;
 - 2/ altitude;
 - 3/ route;
 - 4/ destination;
 - 5/ proposed time of departure;
 - 6/ estimated elapsed time;
 - 7/ alternate;
 - 8/ fuel on board, and, if required:

FLIGHT PLAN PLAN DE VOL			
PRIORITY / PRIORITE FF		ADDRESSEE(S) / DESTINAIRE(S)	
FILING TIME / HEURE DE DEPOT		ORIGINATOR / EXPEDITEUR	
SPECIFIC IDENTIFICATION OF ADDRESSEE(S) AND/OR ORIGINATOR / IDENTIFICATION PRECISE DUIDES DESTINAIRE(S) ET/OU DE L'EXPEDITEUR			
3 MESSAGE TYPE TYPE DE MESSAGE FPL	7 AIRCRAFT IDENTIFICATION IDENTIFICATION DE L'AERONEF AC856	8 FLIGHT RULES REGLES DE VOL I	TYPE OF FLIGHT TYPE DE VOL S
9 NUMBER / NOMBRE 1	TYPE OF AIRCRAFT / TYPE D'AERONEF B747	WAKE TURBULENCE CAT. CAT. DE TURBULENCE DE SILLAGE H	10 EQUIPMENT / EQUIPEMENT SXIC
13 DEPARTURE AERODROME / AERODROME DE DEPART CYUL		TIME / HEURE 0052	
15 CRUISING SPEED VITESSE CROISIERE N0438		ROUTE / ROUTE F330 NA231YYR/M084F330 DCT SCROD	
DCT 56N050W/M084F370 57N040W 57N030W 57N020W 56N010W DCT			
BEL/N0475F370 UR3 WAL UB3 HON DCT			
WCO DCT BNN DCT			
16 DESTINATION AERODROME AERODROME DE DESTINATION EGLL		TOTAL EET / DUREE TOTALE ESTIMEE HR. MIN 0610	ALTN AERODROME AERODROME DE DEGAGEMENT LFPB
2ND. ALTN. AERODROME AERODROME DE DEGAGEMENT			
18 OTHER INFORMATION / RENSEIGNEMENTS DIVER EET/VE00137 YYR0151 SCROD 0210 50W0234			
40W0312 EGGX0350 20W0426 10W0506			
BEL 0526			
REG/CGACA SEL/EHFK			
RENSIGNEMENTS COMPLEMENTAIRES (A NE PAS TRANSMETTRE DANS LES MESSAGES DE PLAN DE VOL DEPOSE)			
19 ENDURANCE / AUTONOMIE HR. MIN E		PERSONS ON BOARD / PERSONNES A BORD P	
SURVIVAL EQUIPMENT / EQUIPEMENT DE SURVIE POLAR POLAIRE DESERT DESERT MARITIME MARITIME JUNGLE JUNGLE S / P / D / M / J		EMERGENCY RADIO / RADIO DE SECOURS UHF UHF VHF VHF ELBA ELBA R / U / V / E	
DINGHIES / CANOTS NUMBER NOMBRE CAPACITY CAPACITE COVER COUVERTURE COLOUR COULEUR D / C		JACKETS / GILETS DE SAUVETAGE LIGHT LAMPES FLUORESCENT FLUORESCENT UHF UHF VHF VHF J / L / F / U / V	
AIRCRAFT COLOUR AND MARKINGS / COULEUR ET MARQUES DE L'AERONEF A /			
REMARKS / REMARQUES N /			
PILOT-IN-COMMAND / PILOTE COMMANDANT DE BORD C /			
FILED BY / DEPOSE PAR		SPACE RESERVED FOR ADDITIONAL REQUIREMENTS / ESPACE RESERVE A DES FINS SUPPLEMENTAIRES	

FIG. 4-2 • ICAO FLIGHT PLAN



pilot so chooses, the pilot may notify ATC by:

- a/ cancelling the IFR flight plan - CANCEL IFR FLIGHT PLAN; or
- b/ converting the IFR flight plan - CHANGE FLIGHT PLAN TO VFR.

Only an acknowledgement should be expected when either of the above messages is transmitted. **To convert to a VFR Flight Plan, the pilot must contact the appropriate flight service station to airfile a VFR Flight Plan if any other flight plan changes are required.** These procedures should not be used when IFR conditions are expected in a subsequent portion of a flight. If, however, following the use of either of these procedures, subsequent IFR operation becomes necessary, a new IFR flight plan must be filed and an ATC clearance received before re-entering IFR conditions.

4.1.8 EQUIPMENT FAILURES

The pilot should report any suspected unreliability or failure of communication or navigation equipment to an air traffic control unit as soon as possible.

4.1.9 ATC CLEARANCE

Pilots of IFR flights must receive ATC clearance before entering controlled airspace. Pilots flying outside of controlled airspace need not receive an ATC clearance; however, they should remember there may be other aircraft operating at random within the immediate vicinity.

NOTE:

When flying IFR in controlled airspace, ATIS will assign an altitude. The pilot is not required to accept an altitude which is not feasible because of turbulence, icing, fuel economy or any other operational reasons. The pilot must simply state that he or she is unable to accept, and request alternate instructions or indicate what altitudes would be acceptable.

After obtaining ATC clearance the pilot in command may not deviate from that clearance except in an emergency or for a TCAS

resolution advisory. If unable to comply with a clearance, the pilot should advise ATC that it cannot be accepted and request a new clearance. The IFR clearance may be cancelled anytime the pilot is operating in VFR weather (except when in airspace which requires all aircraft to maintain IFR). From that point on the flight must be conducted strictly in VFR conditions unless a new IFR clearance is obtained.

Readback of all ATC clearances is compulsory.

This procedure ensures that the pilot understands the clearance and is able to comply with it. When copying an en route clearance, the pilot should not be taxiing or performing any other distracting cockpit duty. If advised that clearance is ready while performing other duties, the pilot should ask that the clearance be held until he or she is ready to copy. The term STAND-BY is sufficient.

If several clearances are obtained while en route, the last clearance supersedes all related items in the preceding clearances. If deviation from a clearance is required by an emergency, and ATC has given priority to that aircraft, the pilot in command *may be requested* to submit a written report within 48 hours to the chief of the ATC facility. When operating under IFR flight rules in VFR weather conditions, the pilot in command is responsible for avoiding other aircraft. The VFR *“see and be seen”* concept applies in this situation.

4.2 DEPARTURE PROCEDURES

4.2.1 GENERAL

Departure control is an ATS control function to ensure separation between departures. Sometimes departure control may suggest a take-off direction other than that normally used in VFR operations. It is preferred to offer the pilot a runway requiring the fewest turns after take-off to place the aircraft on course or into the selected departure route as quickly as possible. There are *preferential runways* at many locations used for local noise abatement programs routing departures away from congested areas. Preferential runways may continue to be used with considerable crosswinds. It is a pilot's responsibility to determine whether or not the cross-wind can be accepted.

Departure control that uses radar normally clears aircraft out of the terminal area by means of standard instrument departures and radio navigation aids. When given a vector that takes the aircraft off a previously assigned route, the pilot is advised briefly what the vector is to achieve. Thereafter, radar service is provided until the aircraft is re-established "on course" using an appropriate navigation aid, and the pilot is advised of the aircraft's position, or a handoff is made to another radar controller with further surveillance capabilities.

Automatic Terminal Information Service (ATIS) is available at many airports and the pilot should monitor it prior to taxi. ATIS frequencies may be found in *Canada Air Pilot*, *Canada Flight Supplement* and Terminal Charts.

This chapter briefly describes procedures that pilots should follow when communicating with ATC and conducting the departure.

Pilots shall maintain a listening watch on the appropriate tower frequency while under control of the tower. Whenever possible, they should make requests for radio checks and taxi instructions on the appropriate ground control frequency. After pilots establish initial contact with the control tower, ATC will advise pilots of any frequency changes required.

After communication has been established with the tower, the terms THIS IS, and other similar terms may be omitted, provided that the omission does not lead to misunderstanding.

4.2.2 REQUEST FOR PUSH-BACK

Controllers may not be able to see all obstructions which an aircraft may encounter during push-back; therefore, clearance for this manoeuvre is not issued. Pilots requesting push-back are advised to "Push-back at *your* discretion" and are given traffic information to the extent possible. Pilots should realize that it is their responsibility to ensure safe push-back before initiating aircraft movement.

4.2.3 PRE-TAXI CLEARANCE PROCEDURES

Certain airports have VHF clearance delivery frequencies whereby pilots of departing IFR aircraft receive IFR clearances before they start taxiing for take-off. Pilots should follow these procedures, where applicable:

- a/ pilots call clearance delivery/ ground control not more than 10 minutes before proposed taxi time or 5 minutes before engine start (unless otherwise advised on the ATIS);
- b/ IFR clearance (or delay information, if clearance cannot be obtained) is issued at the time of this initial call-up;
- c/ after the IFR clearance is received on the clearance delivery frequency, pilots will then call ground control when ready to taxi;
- d/ normally, pilots need not inform ground control that they have received the IFR clearance. Certain locations may, however, require that the pilot inform ground control of a portion of the routing or confirm the clearance;
- e/ if a pilot cannot establish contact on clearance delivery frequency or has not received an IFR clearance before ready to taxi, the pilot contacts ground control and informs the controller accordingly;

TAXI CHART		TORONTO/LESTER B. PEARSON INTL TORONTO ONTARIO					
		D.E.M. & R.					
VOT	ATIS	CLNC DEL	APRON ADVSY	GND	TORONTO TWR	DEP	
114.8	112.15 114.8 120.825 133.1	121.3	TML 1 & 2 122.075 (122.275) TML 3 122.875	121.9 121.65 275.8	118.35 118.7 286.6	128.8 127.575 363.8	

FIG. 4-3 • TORONTO DEPARTURE SEQUENCE

f/ clearance delivery frequencies, where available, are shown on the aerodrome or taxi chart in *CAP*, in the *Canada Flight Supplement* Aerodrome Directory and on the terminal area charts. (See Fig. 4-3).

Where no clearance delivery frequency is established, the pilot should request ATC clearance from the first agency called after start-up: normally ground control or the FSS.

4.2.4 TAXI CLEARANCE

A. GENERAL

On *initial contact with ground control*, the pilot of an IFR aircraft should state destination and planned initial cruising altitude.

If cleared to taxi without restriction to the runway in use, the pilot requires no further clearance to cross any runway en route. Upon receipt of a normal taxi clearance, a pilot should proceed to, but not onto, the runway that is to be used for take-off. If, for any reason, the ground or airport controller requires that a pilot request a further clearance before crossing or entering any of the runways en route to this taxi clearance limit, this requirement is included in the taxi clearance (HOLD SHORT OF...), and must be read back. At larger airports an apron control service may be in operation to expedite aircraft and vehicle traffic on the apron.

EXAMPLE:

Pilot:
 WINNIPEG GROUND DC3 FOXTROT OSCAR VICTOR HOTEL AT HANGAR 3, REQUEST TAXI, SEVEN THOUSAND, TO OTTAWA, WITH INFORMATION BRAVO, OVER.

Ground Control:
 OSCAR VICTOR HOTEL, WINNIPEG GROUND, RUNWAY (number), WIND (in degrees magnetic and knots), TIME (in UTC), ALTIMETER (four-figure group indicating inches of mercury), CLEARED TO TAXI (runway or other specific point, route).

Pilot:
 OSCAR VICTOR HOTEL.

Time and altimeter information may be issued. Runway, wind and altimeter data normally are not issued if included in the current ATIS broadcast and the pilot acknowledges receipt of that message.

ATS does not provide positive control service to aircraft on the apron of an aerodrome but will provide information concerning known traffic and obstructions. Pilots are expected to contact ground control for information on apron traffic prior to taxiing or moving outside their gate area.

B. INSTRUMENT CHECK

The proper functioning of most instruments can be verified by use of the *standard taxi/turning check*. The use of this check prior to flight is mandatory and may be remembered as follows:

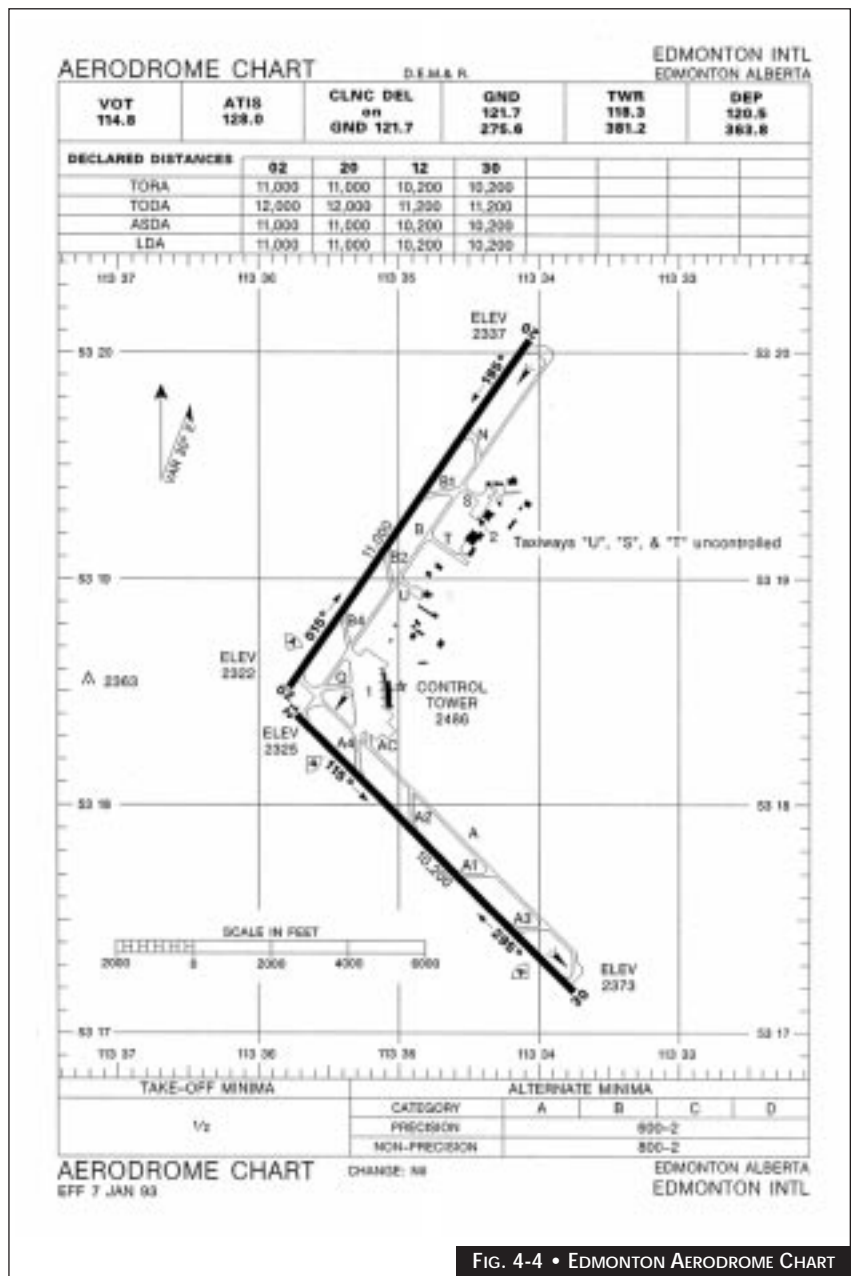

FIG. 4-4 • EDMONTON AERODROME CHART

IN A RIGHT TURN: needle right, ball left, compass increasing, attitude indicator steady, ASI/VSI zero, and all navigational aids tracking; and

IN A LEFT TURN: needle left, ball right, compass decreasing, attitude indicator steady, ASI/VSI zero, and navigational aids tracking.

C. TAXI HOLDING POSITION

The pilot must obtain clearance before leaving a taxi holding position, or where holding positions have not been established, before proceeding closer than 200 ft from the edge of the runway in use. At airports where it is not possible to comply with this provision, taxiing aircraft must remain at a sufficient distance from the active runway to ensure that no hazard to arriving or departing aircraft is created. At some airports separate hold points are established for CAT I and CAT II operations.

Taxi holding position markings are shown in Fig. 4-5.

D. COMMON ATC PHRASEOLOGIES

ADVISE WHEN READY. CONTINUE or CONTINUE TAXIING.

HOLD or HOLD ON (runway number, taxiway) or HOLD (direction) OF (runway number, taxi-way) or HOLD SHORT OF (runway number, taxi-way) or TAXI ON (runway number, taxi-way). TAXI TO POSITION. TURN NOW or TURN LEFT or TURN RIGHT.

E. TRANSPONDER

To avoid causing “clutter” on controllers’ radar displays, pilots should adjust transponders to “standby” while taxiing, and not switch them to ‘on’ (or “normal”) until immediately before take-off. If ATC requires transponder reply immediately after take-off, it includes the appropriate instruction in the IFR clearance.

EXAMPLE:

SQUAWK CODE TWO ONE ZERO ZERO, WHEN AIRBORNE.

F. RUNWAY SELECTION

If the wind is less than 5 kts the controller may assign the “calm wind runway”, provided that the wind direction and speed is clearly indicated. A “calm wind runway” is designated in light of operational advantages based on such factors as:

- 1/ length;
- 2/ better approach;
- 3/ shorter taxiing distance;
- 4/ noise abatement procedures;
- 5/ necessity to avoid flight over populated areas.

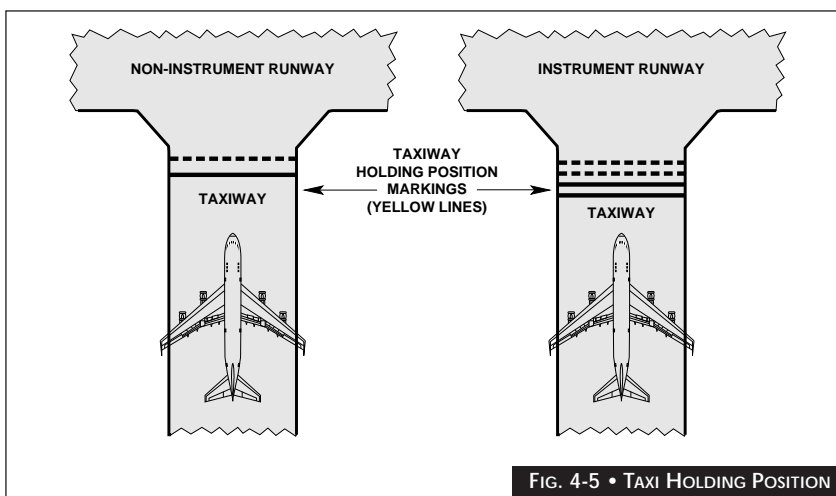

FIG. 4-5 • TAXI HOLDING POSITION

4.2.5 IFR CLEARANCE

A. BASIC PROCEDURES

At locations where a “clearance delivery” frequency is listed, pilots should call on this



FIG. 4-6 • TRANSPONDER CONTROL UNIT

frequency before requesting taxi clearance or not more than five minutes prior to engine start.

At locations where a “clearance delivery” frequency is not listed, ATC normally gives IFR clearance after a flight has received taxi clearance. Due to high fuel consumption during ground running time, some pilots may wish to obtain their IFR and taxi clearances prior to starting engines. Pilots using this procedure should call the tower, using a phrase such as READY TO START NOW or READY TO START AT (time).

Clearances are issued in the following format:

- 1/ prefix (ATC CLEARS);
- 2/ aircraft identification;
- 3/ clearance limit;
- 4/ SID;
- 5/ route;
- 6/ approved altitude (may be omitted if SID clearance issued);
- 7/ departure, en route, approach or holding instructions;
- 8/ special instructions or information;
- 9/ traffic information.

In lieu of the specific route description, ATC may use one of the following phrases when specific conditions are met:

VIA FLIGHT PLANNED ROUTE:

VIA CENTRE STORED FLIGHT PLANNED ROUTE;

VIA REQUESTED ROUTING.

The phrase WHILE IN CONTROLLED AIRSPACE is used with the altitude when an aircraft will be entering or leaving controlled airspace.

EXAMPLE:

MAINTAIN (altitude) WHILE IN CONTROLLED AIRSPACE

Air Traffic Control makes every effort to permit an aircraft to proceed on course with as few turns as possible and to climb to the assigned altitude with as few restrictions as possible. If required for control, ATC specifies the following items in a departure clearance (items 7 and 8);

- 1/ direction of take-off and turn after take-off;
- 2/ initial heading to be flown before proceeding on course;
- 3/ altitude to be maintained before continuing climb at any assigned altitude;
- 4/ time or point at which an altitude or heading change is to be made;
- 5/ any other necessary manoeuvre.

In areas where aircraft may be operating between adjacent airports, ATC may clear an aircraft at the point of departure to the destination airport for an approach. To permit

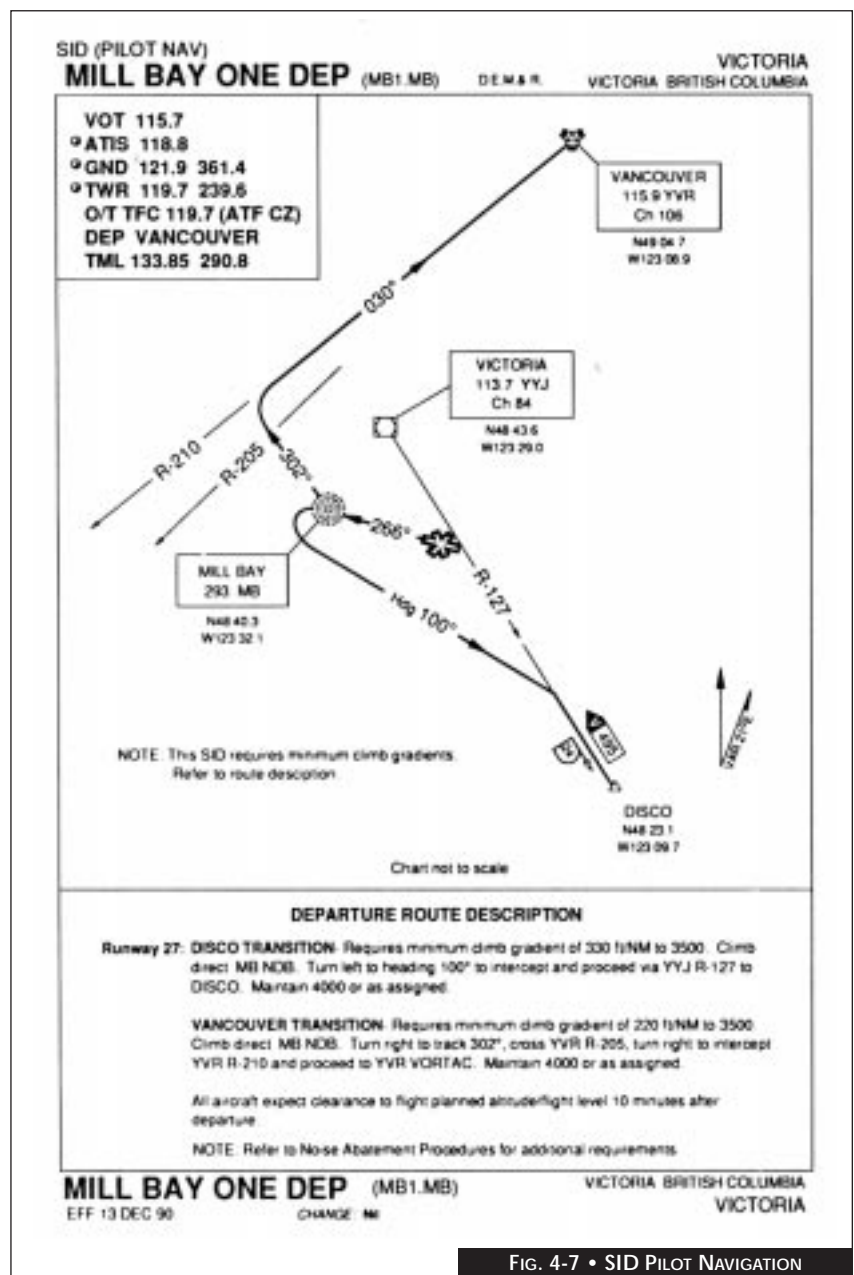

Fig. 4-7 • SID PILOT NAVIGATION

use of this procedure, the following conditions must apply:

- 1/ no other traffic is expected; and
- 2/ the estimated time en route is 25 minutes or less; or
- 3/ the distance between the point of departure and the destination airport is 75 NM or less.

When ATC issues clearances in this manner, the pilot may determine the altitude to be maintained as long as the aircraft remains at or below the altitude specified in the clearance.

EXAMPLE:

ATC CLEARS AIR NOVA ONE ZERO ONE TO THE ST. JOHN'S AIRPORT FOR AN APPROACH. PROCEED VIA VICTOR THREE ONE FIVE. DO NOT CLIMB ABOVE ONE FIVE THOUSAND.

B. MACH NUMBER - CLEARANCES

Clearances to turbo-jet aircraft equipped with a Mach meter may include an appropriate Mach number. The pilot shall adhere to the Mach number approved by ATC within a tolerance of plus or minus decimal zero one (0.01). The pilot must obtain ATC approval before making any change. If an immediate temporary change in Mach numbers is necessary (e.g., due to turbulence), the pilot must notify ATC as soon as possible. When clearance includes a Mach number, the flight should transmit its current Mach number with each position report.

C. STANDARD INSTRUMENT DEPARTURES (SID)

At certain airports an IFR departure clearance may include a coded departure clearance known as a standard instrument departure (SID). Standard instrument departures are published in the *Canada Air Pilot* as *PILOT NAVIGATION SIDs*, where the pilot is required to use the chart as reference for navigation to the en route phase; or as *VECTOR SIDs*, where ATC provides radar navigational guidance to a filed/assigned route or to a fix depicted on the chart. Fig. 4-7 and Fig. 4-8 show an example of each.

Pilots of aircraft operating at airports for which SIDs have been published receive a SID

clearance whenever appropriate. If any doubt exists as to the meaning of the clearance or the communications failure procedure associated with it, the pilot should request a detailed clearance.

In the event of communications failure, the SID procedures refer to the flight plan altitude. Therefore, ATC must know the flight plan altitude in case the pilot must follow the communications failure procedure. Pilots following a centre-stored flight plan must realize that the only flight plan altitude which ATC is aware of is the one contained in the stored flight

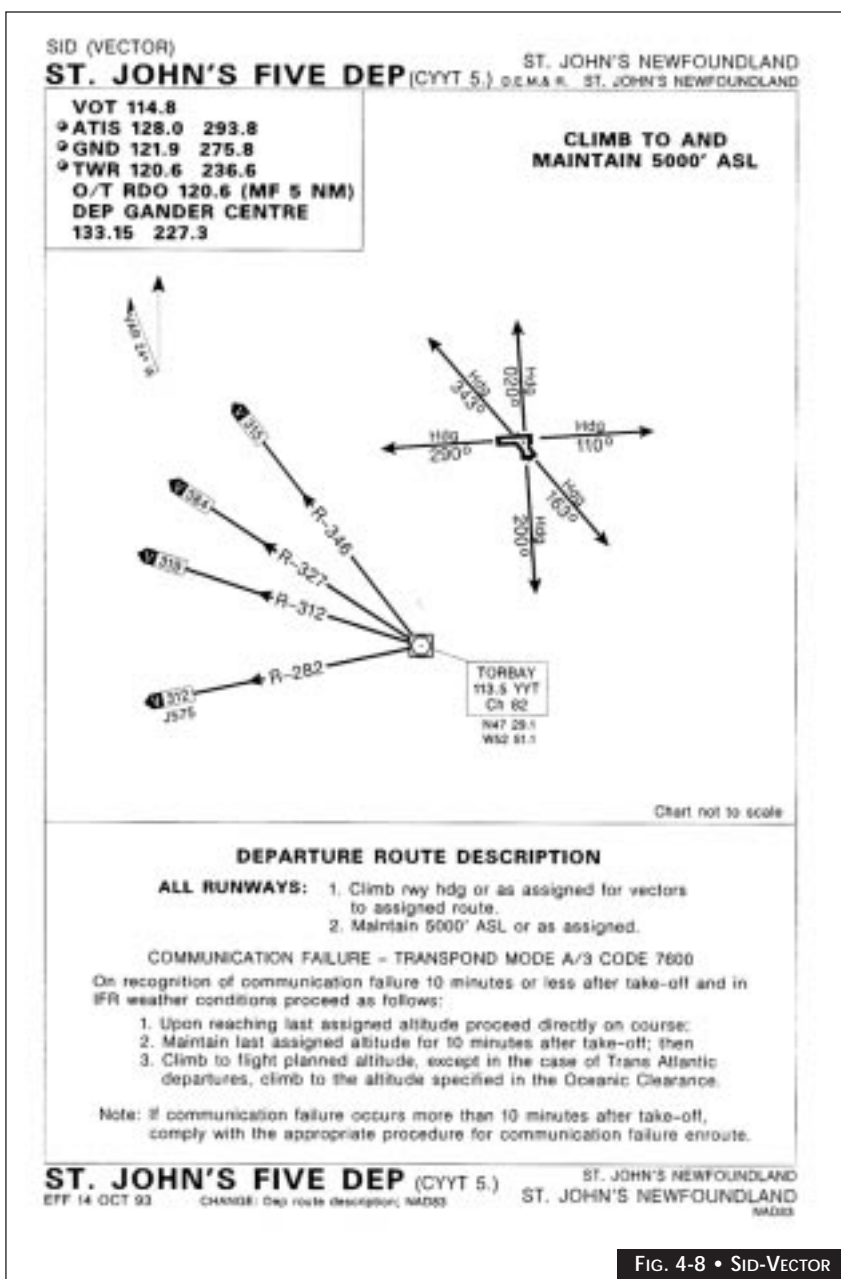

FIG. 4-8 • SID-VECTOR

plan agreement. If the pilot proposes a flight plan altitude different from the centre-stored one, ATC should be advised, and confirmation obtained when requesting the ATC clearance. Thereafter, the pilot should initiate any changes in flight plan altitude when in contact with the departure or en route controller.

The SID normally contains a heading and an altitude to maintain after departure. The only reference to altitude in the initial ATC clearance is that given in the SID. A SID is cancelled only when ATC indicates "SID cancelled".

When instructed to fly or maintain "runway heading" or when flying a SID for which no specific heading is published, pilots are expected to fly or maintain the heading that corresponds with the extended centre line of the departure runway until otherwise instructed by ATC. Drift correction must not be applied; e.g. Runway 04, if the actual magnetic heading of the runway centre line is 044°, then fly a heading of 044° M.

With the flight plan altitude incorporated in the communications failure procedure, there is no further requirement for an assigned altitude, nor is it necessary to cancel the SID clearance. However, when the flight plan altitude is not available, ATC may cancel the SID, provided the aircraft is assigned an *operationally suitable altitude* in the event of communications failure. It is essential that the pilot fully understand each SID and the associated communications failure procedures before accepting a SID clearance.

Unless a lower altitude is requested by the pilot, the following are considered by ATC as operationally suitable altitudes:

- 1/ *piston aircraft* - flight planned altitude or lower; and
- 2/ *other aircraft* - flight planned altitude or altitude as near as possible to the flight planned altitude taking into consideration the aircraft's route of flight. As a guideline an altitude not more than 4,000 ft. below the flight planned flight level in the high level structure will be considered as operationally suitable in most cases.

D. NOISE ABATEMENT PROCEDURES

Pilots must adhere to the associated noise abatement procedures published in *CAP*. Normally, ATC issues radar vectors, but they commence only after the pilot completes the noise abatement procedure. A controller will not issue a clearance or approve a request that would cause a deviation from established noise abatement procedures, except for reasons of safety. Noise abatement procedures A and B for *turbo-jet aircraft* are depicted in Fig. 4-9A and 4-9B. Further details are available in *AIP RAC*.

E. CLEARANCE READ-BACK

The IFR clearance received by a pilot must be read back to the controller. The traffic

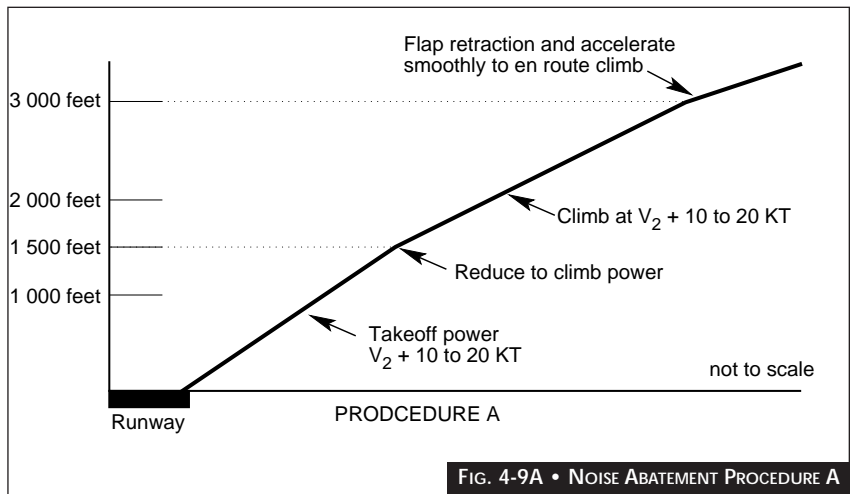

FIG. 4-9A • NOISE ABATEMENT PROCEDURE A

information inserted at the end of the clearance, however, may be acknowledged by the phrase

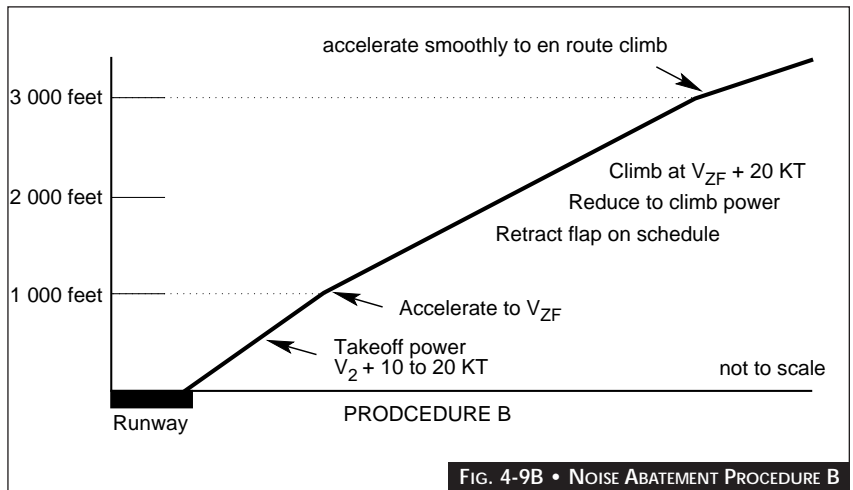

FIG. 4-9B • NOISE ABATEMENT PROCEDURE B

TRAFFIC RECEIVED. Read-back of the SID portion of a clearance should consist of repeating the name of the SID, rather than repeating the detailed SID as published. If the clearance read-back is incorrect, the pilot is advised and the correct data transmitted again to the pilot. These corrections must also be repeated by the pilot to ensure that they have been correctly received. Where published North Atlantic Routes are used, only the NAR number is required in the read-back.

Where radar is available, controllers provide appropriate vectors to allow climb to cruising altitude with the least possible delay. When vector headings have been assigned by ATC, pilots shall read back the headings to the controller.

F. VFR RELEASE OF AN IFR AIRCRAFT

Before departing under visual conditions on an IFR flight plan, the pilot must receive prior permission from the ATC centre (through FSS, control tower or direct controller-pilot communications (DCPC)) and request an IFR clearance in the air. Air Traffic Control may approve an IFR aircraft's request to depart and maintain VFR until it receives an IFR clearance, with the restriction to maintain VFR until a time, altitude, or location at which time an IFR clearance can be expected. (If the VFR restriction specifies a time or a location, the pilot must not enter Class A or B airspace).

G. TAKE-OFF CLEARANCE

When ready for take-off the pilot should request take-off clearance, stating the runway. Upon receipt of take-off clearance, the pilot shall acknowledge and take off without delay, or inform ATC if unable to do so.

EXAMPLE:

PILOT: WINNIPEG TOWER YANKEE
FOXTROT PAPA REQUEST TAKE-OFF
RUNWAY THREE SIX

TOWER: YFP WINNIPEG TOWER (any special information - hazards, obstructions, etc.) CLEARED FOR TAKE-OFF (control instructions - turn after take-off, wind information if required, etc.)

PILOT: YANKEE FOXTROT PAPA

A pilot may request to use the full length of the runway for take-off at any time. However, if the pilot has not begun an intersection take-off and requires back-tracking on the live runway, the pilot shall indicate intentions and obtain a clearance for the manoeuvre before entering the runway.

A pilot may request, or the controller may suggest, *take-off using only part of a runway*. Air Traffic Control approves the pilot's request as long as noise abatement procedures, traffic and other conditions permit. If the controller suggests the manoeuvre, he or she states the available length of the runway. The pilot must ensure that the portion of the runway to be used will be adequate for the take-off run.

To expedite movement of airport traffic and achieve spacing between arriving and departing aircraft, take-off clearance may include the word "*immediate*". On acceptance of the clearance, the aircraft shall taxi onto the runway and take off in one continuous movement. If the pilot judges that compliance would adversely affect the operation, the clearance should not be accepted. Pilots planning a static take-off (i.e., a full stop in "position" on the runway) or a delay in take-off should indicate this when requesting take-off clearance.

To expedite an aircraft departure the controller may suggest a *take-off direction other than into wind*. The pilot must decide whether to:

- 1/ make the take-off;
- 2/ wait for take-off into wind; or
- 3/ request take-off in another direction.

For an IFR flight, the *initial call* to Departure Control should contain the following minimum information:

- 1/ call sign;
- 2/ runway of departure;
- 3/ passing altitude (nearest 100 ft); and
- 4/ assigned (SID) altitude.

4.2.6 TAKE-OFF CRITERIA AND MINIMA

A. TAKE OFF MINIMA

Take-off minima, as prescribed in the *Air*



Regulations, are based on specified visibility for the departure runway and are published on individual aerodrome charts in the *CAP*. The standard take-off minimum visibility is RVR 26 or 1/2 SM. At airports where obstacles in the take-off path do not allow standard take-off minima, specified minima and departure procedures are published on the aerodrome chart. The criteria for determining take-off minima follows.

B. TAKE OFF CRITERIA

The *minimum climb gradient* after take-off is based on the aircraft crossing the departure end of the runway at 35 feet AGL, climbing at 200 feet per nautical mile and climbing to 400 feet above airport elevation (AAE) before turning (in any direction), unless otherwise specified in the procedure. A slope of 152 feet per mile, starting no higher than 35 feet above the departure end of the runway, is assessed for obstacles. A minimum of 48 feet of obstacle clearance is provided for each mile of flight.

If no obstacles penetrate the 152 feet per mile slope, specific IFR departure procedures are not published and the take-off minimum is visibility of 1/2 SM. If obstacles penetrate the slope, obstacle avoidance procedures are specified (see Fig. 4-7). These procedures may prescribe:

- 1/ a *visual climb* to allow the obstacles to be seen;
- 2/ a *climb gradient* greater than 200 feet per NM to overfly the obstacle;
- 3/ a detailed *departure route* to stay clear of the obstacles; or
- 4/ a *combination* of the above.

If aircraft performance allows the use of prescribed routings and/or prescribed climb gradients, then a take-off visibility of 1/2 SM is authorized. However, if visual manoeuvring is the primary requirement for obstacle avoidance, then specified take-off minimum visibilities will be used. These visibilities are determined by the aircraft speed in the climb which will place the aircraft in a certain category (see Article 4.6.2 for categories and speeds). Essentially, the pilot is responsible for avoiding obstacles in the departure path until the aircraft reaches a safe altitude such as the minimum obstruction clearance altitude (MOCA) on an airway.

Therefore, each pilot prior to departing an airport on an IFR flight should consider the aircraft performance and the type of terrain and other obstacles on or in the vicinity of the departure airport and:

- 1/ determine whether a departure procedure or SID is available for obstacle avoidance;
- 2/ determine if obstacle avoidance can be maintained visually or that the departure procedure should be followed; and
- 3/ determine what action will be necessary and take such action that will ensure a safe departure.

Departures from runways which require the use of an instrument departure procedure or specified take-off minima will be asterisked (*) in the take-off minima block on the aerodrome chart in *CAP*. If a departure has not yet been assessed by Transport Canada, the term "standard" (STD) or "unassessed" is used. In this case, the *pilot must determine a safe departure procedure* using minimum IFR altitudes, visual climb, missed approach procedures, topographical maps and local knowledge.

C. OBSTACLE AND TERRAIN CLEARANCE

Civil and military ATC procedures do not require the air traffic controller to provide terrain and obstacle clearance in their departure instructions. Terms such as "ON DEPARTURE, RIGHT TURN CLIMB ON COURSE" or "ON DEPARTURE LEFT TURN ON COURSE" are not to be considered specific departure instructions. *It remains the pilot's responsibility to ensure that terrain and obstacle clearance has been achieved.*

4.3 EN ROUTE PROCEDURES

4.3.1 POSITION REPORTS

Pilots of IFR and controlled VFR flights which are not radar identified must make position reports over compulsory reporting points portrayed on the terminal and en route charts, and over any other reporting points specified by ATC. Normally, aircraft operating in the high-level airspace are not requested to report over a reporting point that is not depicted on a high-level en route chart.

Reporting points are indicated by a symbol on the appropriate charts. The “*designated compulsory*” reporting point is a solid triangle and the “*on request*” reporting point symbol is an open triangle. Reports passing an “*on request*” reporting point are only necessary when requested by ATC. Therefore, no mention of an “*on request*” reporting point need be made in any position report unless it has been requested by ATC. For *wrong way altitudes*, position reports are required at all reporting points, even when radar identified.

En route IFR flights should establish direct controller-pilot communications (DCPC) wherever possible. Peripheral (PAL) transmitter-receiver sites have been established at a number of locations to extend the communication coverage. While DCPC provides direct contact with the IFR unit, at locations without a control tower but with an

FSS, pilots must also communicate with the FSS for local traffic information.

Whenever DCPC cannot be established, pilots should make position reports to ATC through the nearest communications agency along the route of flight. When the pilot-in-command of an IFR aircraft is informed that the aircraft has been RADAR IDENTIFIED, position reports over compulsory reporting points are *no longer required*. Pilots will be informed when to resume normal position reporting.

So that flight information and alerting service can be provided to all IFR flights *outside controlled airspace*, pilots should make position reports over all NAVAIDS along the route of flight to the nearest station having air/ground communications capability.

4.3.2 ALTITUDE

A. GENERAL

Pilots must determine and maintain the required obstacle clearance altitude as prescribed in the *Air Regulations*.

Within controlled airspace, ATC is not permitted to approve or assign any IFR altitude below the “*minimum IFR altitude*”, the lowest IFR altitude established in a specific airspace. Depending on the airspace concerned, this may be the:

- 1/ minimum en route altitude (MEA);
- 2/ minimum obstruction clearance altitude (MOCA);

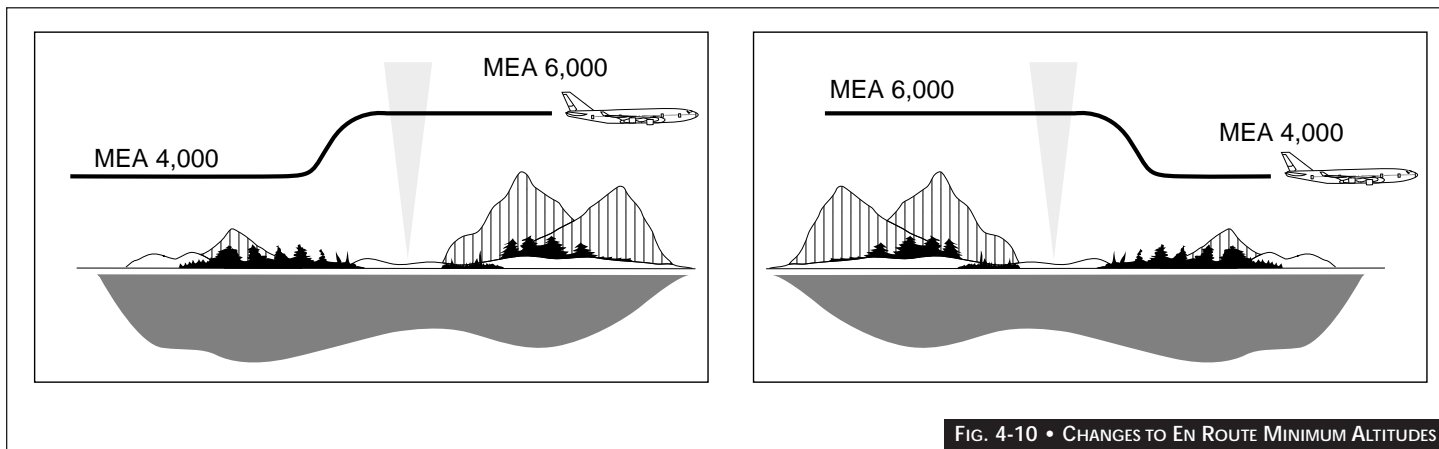

FIG. 4-10 • CHANGES TO EN ROUTE MINIMUM ALTITUDES



- 3/ geographic area safe altitude (GASA);
- 4/ minimum sector altitude (MSA);
- 5/ safe altitude 100 NM; or the
- 6/ minimum vectoring altitude.

When operating at an altitude below the MEA for a subsequent portion of the route, the pilot must obtain clearance in sufficient time to enable the aircraft to cross the fix at or above the minimum altitude established beyond the fix (Fig. 4-10).

Descent below the minimum IFR altitude of a route segment must not occur until “*fix passage*” into a segment with a lower minimum IFR altitude (Fig. 4-10).

On an airway, ATC may approve altitudes below the MEA, but not below the MOCA, when the pilot of an IFR flight requests them in the interest of flight safety (e.g. due to icing conditions). Pilots should realize that below the MEA, signal coverage required to navigate within the airspace protected for the route may not be adequate. This could result in conflict with adjacent air traffic or loss of terrain clearance.

B. MINIMUM IFR ALTITUDES

Minimum en route altitudes (MEAs) are established for all designated low-level airways and air routes in Canada, and are shown on the Low Altitude En route charts. Minimum en route altitudes are also established for certain high-level airways and are shown on the High Altitude En route charts.

Under conditions of standard temperature and pressure, the *minimum obstruction clearance altitude (MOCA)*, in non-mountainous regions, provides 1,000 ft clearance above all obstacles lying within the lateral limits of an airway or air route segment.

Where the MOCA is lower than the MEA, the MOCA is also published on the en route charts. Where the MEA and MOCA are the same, only the MEA is published.

The *MOCA* (or the MEA when the MOCA is not published) is the lowest altitude for the airway or air route segment at which an IFR flight may be conducted under any circumstance. This altitude is provided so that

pilots are readily aware of the lowest safe altitude that could be used in an emergency such as a malfunctioning engine or icing conditions.

The *minimum reception altitude (MRA)* may be published at intersections on the en route charts when the MRA for a VHF/UHF intersection is higher than the MEA for the segment of the airway on which the intersection is located.

The *Geographic Area Safe Altitude (GASA)* has the purpose of indicating on en route charts a safe altitude at which an aircraft can operate and maintain a 2,000 ft. clearance over known obstacles and terrain within the delineated geographic area. On southern charts, the geographic area is 2° of latitude by 4° of longitude and on northern charts is 2° of latitude and 8° of longitude.

The *100 NM safe altitude* is published on approach plates to indicate the altitude which is 1,000 ft above the highest obstacles within 100 NM of the aerodrome.

The *minimum sector altitude (MSA)* is depicted on the approach plate and is based on a 25 NM circle *from the indicated navaid*. It provides 1,000 ft above the highest obstacle within the various sectors.

The *transition altitude* is published on instrument approach plates to provide a 1,000 feet obstacle clearance on a transition to an approach facility.

The *minimum vectoring altitude* is used by ATC to determine minimum vectoring altitudes within various sectors on the radar screen. These altitudes are adjusted for colder than normal temperatures in the winter months.

C. ALTITUDES IN DESIGNATED MOUNTAINOUS REGIONS

Pilots shall conduct IFR flights within designated mountainous regions (Fig. 4-11), when outside of designated airways and air routes, at an altitude at least 2,000 ft above the highest obstacle within 5 NM of the aircraft over the Western Cordillera and Arctic Islands mountainous regions. Over the mountainous regions of Quebec and the Maritime Provinces, it is 1,500 ft above the highest obstacle.

On designated airways and air routes, pilots may operate IFR flights at the published MEA/MOCA; however, in winter, when air temperatures may be much lower than those of the ICAO Standard Atmosphere (ISA), they should operate at altitudes at least 1,000 ft higher than the published MEA/MOCA.

CAUTION:

The combination of extremely low temperatures and the effect of mountain waves may cause an altimeter over-reading by as much as 3,000 ft. For further details, refer to “Major Errors of the Pressure Altimeter”, published in AIP Canada.

D. ALTITUDE REPORTS

Pilots shall report reaching the altitude to which the flight has been initially cleared. When climbing or descending en route, pilots shall report when leaving a previously assigned altitude and when reaching the assigned altitude.

On *initial contact* with ATC or when changing from one ATC frequency to another, pilots should state the assigned cruising altitude and, when applicable, the altitude through which the aircraft is climbing or descending to the nearest 100 feet to verify the Mode C readout.

EXAMPLE:

MONTREAL DEPARTURE, CANADIAN 775 OFF RUNWAY 28, THROUGH 1,500 CLIMBING TO 5,000.

EDMONTON CENTRE, AIR CANADA 801 HEAVY, 8,000 CLIMBING TO FLIGHT LEVEL 350.

Air Traffic Control may request verification of altitude if the pilot does not report it on initial contact. On departure, stating passing altitude allows the controller to verify Mode C operation and thus provide more efficient service.

4.3.3 CLIMB OR DESCENT

A. GENERAL

When an aircraft reports vacating an altitude, ATC may assign the altitude to another aircraft.

In all cases, ATC expects that a climb or descent shall be at the optimum rate and proceed without interruption. If a pilot must level off or adjust to a slow climb or descent, the pilot must advise ATC. The *minimum descent rate* is considered to be at least 500 feet per minute (fpm) for piston aircraft and 1,000 fpm for turbine aircraft.

If a descending aircraft must level off at 10,000 ft to comply with aircraft speed limits while cleared to a lower altitude, the pilot must receive clearance from ATC for this interruption of the normal descent rate.

B. VFR CLIMB AND DESCENT

Air Traffic Control clears IFR aircraft for a VFR climb or descent only if a pilot requests it. During a VFR altitude change, pilots must provide their own separation from all other aircraft.

VFR altitude changes for IFR aircraft within Class A or B airspace are not permitted.

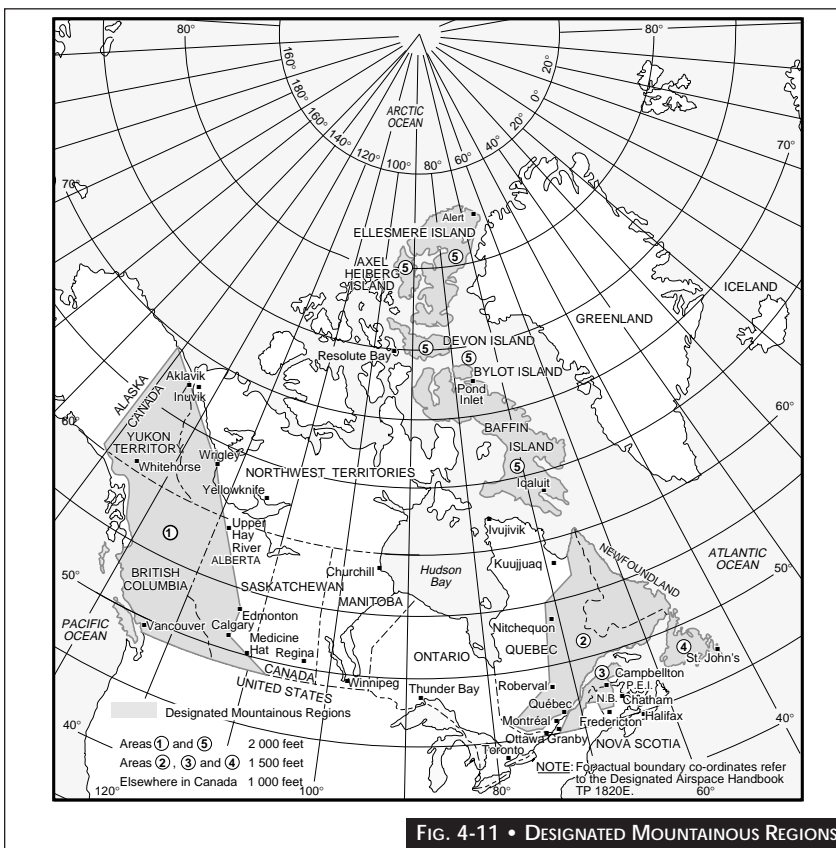

FIG. 4-11 • DESIGNATED MOUNTAINOUS REGIONS



4.3.4 IFR FORMATION FLIGHTS

When civil aircraft are involved with IFR formation flight, ATC will provide for increased lateral separation. The formation leader must liaise closely with the appropriate ATC unit.

4.3.5 ONE-THOUSAND-ON-TOP

On the pilot's request, ATC may authorize "at least 1,000 on top" IFR flight provided that:

- 1/ the altitude being maintained is a least 1,000 ft above all cloud, haze, smoke or other formations;
- 2/ the flight visibility above the cloud formation is at least three miles;
- 3/ the top of the cloud formation is well defined;
- 4/ the altitude appropriate to the direction of flight is maintained when cruising in level flight;
- 5/ the aircraft will operate within Class C or D airspace.

"At least 1,000 on top" is not permitted in Class A or B airspace, nor below the applicable minimum IFR altitude. The pilot must maintain adequate separation from all other aircraft.

4.3.6 CLEARANCE LIMIT

The clearance limit, as specified in an ATC clearance, is the point to which an aircraft is cleared. Normally, ATC delivers further clearance to a flight before it arrives at the clearance limit. Occasions may arise, however, when this may not be possible.

If further clearance is not received, the pilot shall hold at the clearance limit on the inbound track, maintaining the last assigned altitude, and request further clearance. For example, if a flight approaches a fix on a track of 090°, holding should be accomplished at the fix on an inbound track of 090°. If the pilot cannot establish communication with ATC, they then should proceed according to communications

failure procedures found in the *CFS*.

Pilots must determine whether or not they can comply with a clearance in case of a communication failure. If they are any doubts, *the clearance may be refused but acceptable alternatives should be specified*.

The procedures for clearance limits also apply to *altitude restrictions*. For instance, if the pilot is cleared to cross a fix at 10,000 ft. and owing to unforeseen circumstances (wind or OAT changes) is unable to make the restriction, he or she should advise ATC and request further instructions. *If unable to contact ATC*, a hold should be initiated in the climb or descent, using the standard holding speeds, until the restriction is made. At that time the flight can continue en route.

4.4 HOLDING PROCEDURES

4.4.1 GENERAL

Pilots must adhere to the aircraft entry and holding manoeuvres, as described, because ATC provides lateral separation in the form of "airspace to be protected" in relation to the holding procedure.

4.4.2 HOLDING CLEARANCE

A holding clearance issued by ATC includes at least the:

- 1/ clearance to the holding fix (holding fix may be described by a facility such as an NDB, VOR or a radial/DME);
- 2/ direction to hold from the holding fix, i.e. north, south, etc. (not included in DME hold clearance);
- 3/ a specified radial, course, or inbound track unless the holding pattern is published;
- 4/ the DME distance (if DME is used) at which the "fix end" and "outbound end" turns are to be commenced, e.g. HOLD BETWEEN (number of miles) AND (number of miles);
- 5/ time to expect further clearance, time to expect approach clearance, or time to leave the fix in the event of communications failure.

A standard right hand pattern is implied in the holding clearance and shall be flown unless "LEFT TURNS" are specified.

NOTES:

1. An "expect further clearance time" usually is followed by further clearance, or an "expect approach clearance time" when traffic conditions permit.
2. If the "outbound end" DME is omitted, the pilot is expected to hold at the "fix end" DME using the appropriate timing.

Air Traffic Control does not use any of the following as a holding fix:

- 1/ an unmonitored NAVAID;
- 2/ a DME fix located within the cone of ambiguity (when holding away from the NAVAID, the entire holding cone of ambiguity);
- 3/ an intersection formed by radials or courses that cross at an angle of less than 45°; or
- 4/ an intersection formed by one or more ADF bearings from LF/MF NAVAIDS.

During entry and holding, pilots shall make all turns to achieve an average bank angle of at least 25° or a rate one turn of 3°/sec, whichever requires the *lesser bank*, adjusted for wind. Unless the ATC clearances contain instructions to the contrary, pilots shall make all turns to the right, after initial entry into the holding pattern.

Occasionally, a pilot may reach a clearance limit before obtaining further clearance from ATC. In this event, the pilot should slow to below the maximum holding speed (if required) and enter a standard holding pattern on the inbound track to the clearance limit and request further assistance.

EXAMPLE 1:

A westbound flight on Golf 1, cleared to Moncton (QM) NDB reaches QM before obtaining further clearance. The pilot is to hold at QM on an inbound track of 287° and request further clearance.

EXAMPLE 2:

The published missed approach procedure for an ILS RWY 24 approach at Halifax is:

CLIMB TO 2200 FEET ON TRACK OF 236°

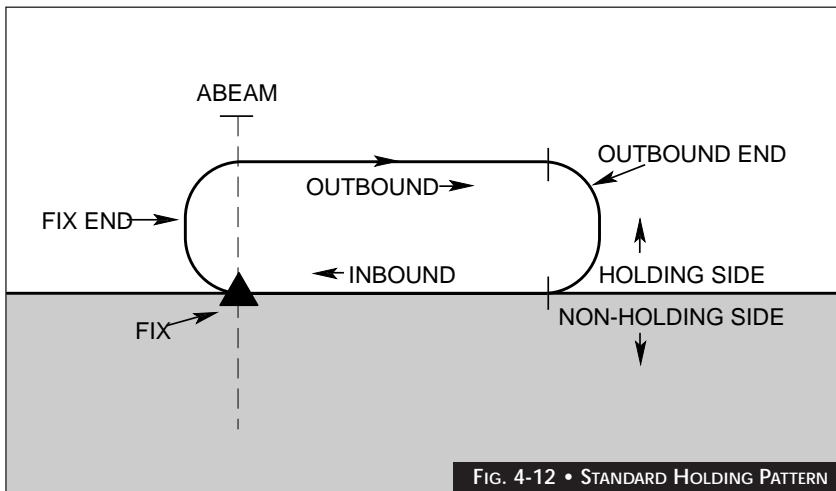

FIG. 4-12 • STANDARD HOLDING PATTERN



TO GOLF NDB. A pilot missing an ILS approach to RWY 24, and not in receipt of further clearance is to proceed directly to the GOLF NDB, execute a direct entry procedure (right turn), and hold at the GOLF beacon on an inbound track of 236°, one minute pattern at 2200 ft and request further clearance.

If for any reason a pilot is unable to conform to these procedures, the pilot should advise ATC as early as possible.

4.4.3 STANDARD HOLDING PATTERN

A standard holding pattern is depicted in Fig. 4-12 and described below for still air conditions.

- a/ Having entered the holding pattern, on the second and subsequent arrivals over the fix, the pilot executes a right turn to fly an outbound track that positions the aircraft most appropriately for the turn onto the inbound track.
- b/ Continue outbound for one minute if at or below 14,000 ft ASL or 1 1/2 minutes if above 14,000 ft ASL. (ATC specifies distance, not time, on a DME hold).
- c/ Turn right so as to realign the aircraft on the inbound track. When holding at a VOR, pilots should begin the turn to the outbound leg at the time of station passage as indicated on the TO-FROM indicator.

A controller may approve a pilot's request to deviate from a standard holding procedure provided that the additional airspace is protected. If the pilot has to hold for a substantial length of time (usually in a non-radar environment) because of other aircraft on approach, *ATC may be able to extend the pilot's leg lengths* substantially to give the pilot more time to calculate fuel conditions, check alternate airport weather, etc.

4.4.4 ENTRY PROCEDURES

The pilot shall enter a holding pattern according to the aircraft's heading in relation to the three sectors shown in Fig. 4-13, recognizing a zone

of flexibility of 5° on either side of the sector boundaries. For holding on VOR Intersections or VOR/DME fixes, entries are limited to the radials or DME arcs forming the fix as appropriate.

Sector 1 procedures (PARALLEL ENTRY) are:

- a/ Upon reaching the fix, turn onto the outbound heading of the holding pattern for the appropriate period of time.
- b/ Turn left to intercept the inbound track or to return directly to the fix.
- c/ On the second arrival over the fix, turn right and follow the holding pattern.

Sector 2 procedures (OFFSET ENTRY) are:

- a/ Upon reaching the fix, turn to a heading that results in a track having an angle of 30° or less from the inbound track reciprocal on the holding side.
- b/ Continue for the appropriate period of time, then turn right to intercept the inbound track and follow the holding pattern.

Sector 3 procedure (DIRECT ENTRY) is:

Upon reaching the fix, turn right and follow the holding pattern.

When crossing the fix to enter a holding pattern, the appropriate ATC unit shall be advised "ENTERING THE HOLD." *ATC MAY ALSO REQUEST* that the pilot report "ESTABLISHED IN THE HOLD". The pilot is to report "established" (if requested) only when crossing the fix after having completed the entry procedure.

4.4.5 NON-STANDARD HOLDING PATTERN

A non-standard pattern is one in which:

- a/ the fix end and outbound end turns are to the left; and/or
- b/ the planned time along the inbound track, is other than the standard 1 minute or 1 1/2 minute leg appropriate for the altitude flown.

Entry procedures to a non-standard pattern requiring left turns are oriented in relation to the 70° line on the holding side (Fig. 4-14), just as in the standard pattern.

4.4.6
TIMING

The still air time for flying the initial outbound leg of a holding pattern should normally be *one minute* if at or below 14,000 ft, or *1 1/2 minutes* if above 14,000 ft ASL. However, the pilot should make due allowance in both heading and timing to compensate for known wind effect.

After initial circuit of the pattern, timing should begin abeam the fix or on attaining the outbound heading, whichever occurs later. The pilot should increase or decrease outbound times, in recognition of winds, to effect 1 or 1 1/2 minutes (appropriate to altitude) *inbound to the fix*.

When the pilot receives ATC clearance specifying the time of departure from the holding point, the flight pattern should be adjusted within the limits of the established holding pattern to leave the fix as near as possible to the time specified (keeping in mind that a rate 1 turn takes 2 minutes to complete a 360° turn).

4.4.7
SPEED LIMITATIONS

Pilots must enter and fly holding patterns at or below the following airspeeds:

- a/ *Propeller-driven aircraft* 175 kts IAS
- b/ *Turbo-jet aircraft*
 - 1/ up to 14,000 ft, inclusive 230 kts IAS
 - 2/ above 14,000 ft 265 kts IAS
- c/ *Turbo-prop aircraft* may operate at normal climb IAS while climbing in a holding pattern. *Turbo-jet aircraft* may operate at 310 kts IAS or less while climbing in a holding pattern.

Pilots must advise ATC immediately if airspeeds greater than those specified above become necessary for any reason, including turbulence, or if the pilots are unable to accomplish any part

of the holding procedure. When this higher speed is no longer necessary, pilots should again operate their aircraft at the specified airspeeds, and notify ATC.

NOTES:

1. *Airspace protection for turbulent air holding is based on a maximum of 280 kts IAS or Mach .8, whichever is lower. Adverse impact on the flow of air traffic may result when aircraft hold at speeds higher than these.*

2. *Consult NOTAM or AIP for any changes in maximum holding speeds. At the time of going to print, a temporary change to maximum holding speeds was in effect via NOTAM as follows:*

- i/ up to 6,000 ft. inclusive - 200 kts;
- ii/ above 6,000 ft. to 14,000 ft. inclusive - 210 kts.

After departing a holding fix, pilots should *resume normal speed*, subject to other requirements such as speed limitations in the vicinity of controlled airports and specific ATS requests.

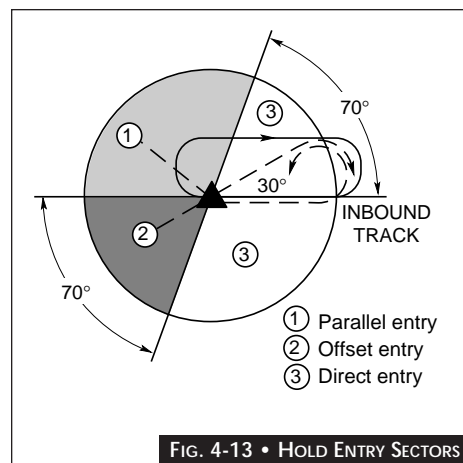

FIG. 4-13 • HOLD ENTRY SECTORS

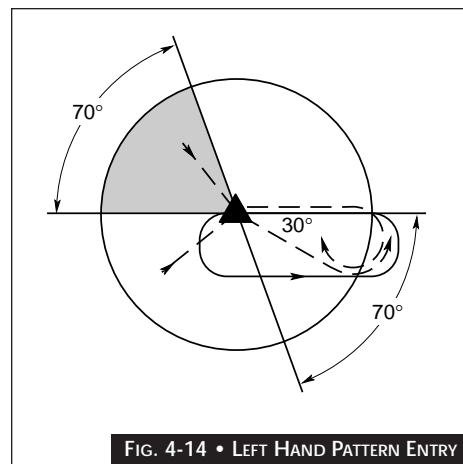

FIG. 4-14 • LEFT HAND PATTERN ENTRY

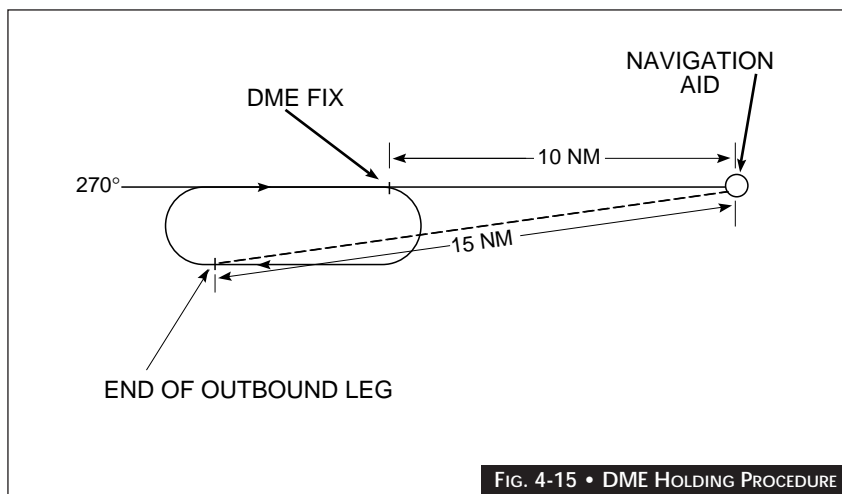

FIG. 4-15 • DME HOLDING PROCEDURE

4.4.8 DME HOLDING PROCEDURES

Distance Measuring Equipment holding is subject to the same entry and holding procedures previously described except that distances, in nautical miles, are used instead of time values.

In describing the direction from the fix on which to hold and the limits of a DME holding pattern, the ATC clearance specifies the DME distance from the NAVAID at which the inbound and outbound legs are to be determined. The end of each leg is determined by the DME indications.

EXAMPLE:

An aircraft cleared to the 270 RADIAL 10 MILE DME FIX, to HOLD BETWEEN 10 AND 15 MILES, shall hold inbound on the 270° radial (Fig. 4-15), commence the turn to the outbound leg when the DME indicates 10 NM and commence the turn to inbound leg when the DME indicates 15 NM.

4.4.9 SHUTTLE PROCEDURE

A shuttle procedure is defined as a manoeuvre involving a descent or climb in a holding pattern. In the approach phase, it is normally prescribed where a descent of more than 2,000 ft. is required during the initial or intermediate approach segments. It can also be required when performing a missed approach or departure procedure from certain airports. A shuttle procedure shall be executed in the holding pattern as published unless instructions contained in an ATC clearance direct otherwise.

4.4.10 HOLDING PATTERNS DEPICTED ON EN ROUTE AND TERMINAL CHARTS

At some high traffic density areas holding patterns are depicted on IFR terminal area and en route charts. (Fig. 4-16). When pilots are cleared to hold at a fix where a holding pattern is published, or if clearance beyond the fix has not yet been received, pilots are to hold in accordance with the depicted pattern using

normal entry procedures and timing. ATC will use the following phraseology when clearing an aircraft to hold at a fix which has a depicted holding pattern:

CLEARED to the (fix),
HOLD AS PUBLISHED.
EXPECT FURTHER
CLEARANCE AT (time)

If a pilot is instructed to depart a fix which has a published hold, at a specified time, the pilot has the option to:

- a/ proceed to the fix, then hold until the "depart fix" time specified; or
- b/ reduce speed to make good the "depart fix" time; or
- c/ a combination of (a) and (b).

NOTE:

The holding direction means the area in which the hold is to be completed in relation to the holding fix, e.g., North East, North West etc. If the required pattern is different than that depicted, a detailed holding instruction will be issued by ATC.



FIG. 4-16 • PUBLISHED HOLDING PATTERNS

4.5 ARRIVAL PROCEDURES

4.5.1 DESCENT PLANNING

A. INTRODUCTION

Except where standard terminal arrival routes (STARs) or profile descents are published, pilots must plan their own descent profiles, even when under radar control. As a rule pilots are cleared for descent in plenty of time to reach the appropriate minimum IFR altitude for the segment, or the altitude assigned by ATC. Pilots should obtain ATIS or operational information from FSS or Ground Control as early as possible in order to plan the descent.

Occasionally, in busy terminal areas, the aircraft may have to be kept at an intermediate altitude due to traffic below. When this happens, the pilot may be faced with a considerable descent (e.g., 3,000 ft) over a fairly short distance. The pilot should keep a clear mental picture of where the aircraft is in the approach sequence, so as to begin descent as soon as cleared to a lower altitude. It is far better to reduce vertical speed towards the end of the descent than to increase it as the aircraft intercepts the final approach track.

Standard terminal arrival routes are published in the *Canada Air Pilot* for some major airports. A STAR, as used in Canada, is roughly similar to a SID in that it is an ATC clearance to proceed under certain conditions, and is referred to by name. (See Fig. 4-18). It provides a transition from en route to the terminal radar vector environment, and includes routing and speed and altitude restrictions that otherwise would be spelled out word for word. Profile Descent charts depicting procedures with altitude and speed restrictions may be published at some busy terminals. Fig. 4-19 is an example.

B. ARRIVAL FIXES

1. **TERMINAL AREA FIXES - GENERAL:** Terminal area fixes and points include, but are not limited to, the Initial Approach Fix (IAF), Intermediate Fix (IF) the Final Approach Course Fix (FACF), the Final Approach Fix

(FAF), glide path interception point, and the holding fix.

2. **FIXES FORMED BY INTERSECTION:** Because all navigational facilities have accuracy limitations, the identified geographic point may be anywhere within an area (the *fix tolerance area*) that surrounds its plotted point of intersection. Fig. 4-17 illustrates the intersection of two radials or tracks from different navigation facilities.
3. **FIX TOLERANCE FACTORS:** The dimensions of the fix tolerance area are determined by the accuracy of the navigational system that supplies the information. The factors that determine the accuracy of a system are: ground station tolerance; airborne receiving system tolerance; pilot tolerance; and distance from the facility. There is a difference between the over-all tolerance of the intersecting facility and along-track facility. This is because pilot tolerance is not applied to the former. The following values are used in the development of instrument approach procedures.

VOR RADIAL	ADF BEARING
ALONG TRACK ± 4.5°	ALONG TRACK ± 5.0°
INTERSECTING ± 3.6°	INTERSECTING ± 5.0°
ILS FRONT COURSE	ILS BACK COURSE
LOCALIZER	LOCALIZER
ALONG TRACK ± 1.0°	ALONG TRACK ± 5.0°
INTERSECTING ± 0.5°	INTERSECTING ± 5.0°

FIX TOLERANCES:

DME: ±0.25 NM plus 1.25% of the distance to the antenna, whichever is greater (Slant range correction is taken into account before application of fix tolerance).

VHF MARKER BEACONS
±1.0 NM

ILS MARKERS
±0.5 NM

The point of printing all these values is to show that all navigational aids have plus or minus tolerances. If the pilot wants to remain within the confines of an airway, for example, he or she must attempt to fly along the centre of the airway.

4.5.2 STANDARD TERMINAL ARRIVAL ROUTE (STAR)

To simplify clearance procedures, coded STARs have been designated at some airports and published in the *CAP*. STARs provide for a smooth transition between the en route and approach phase. Fig. 4-18 shows a STAR for Calgary. If any doubt exists as to the meaning of the STAR, a detailed clearance should be requested.

4.5.3 PROFILE DESCENTS

A. GENERAL

Profile descent procedures permit arriving aircraft to conduct an uninterrupted descent from cruising altitude or flight level toward the airport. Such procedures improve ATC system efficiency, reduce frequency congestion in the terminal area, and provide fuel economies for users through adherence to standardized crossing altitudes and airspeeds. Fig. 4-19 shows a profile descent for Toronto.

Profile descent procedures contain vertical navigation instruction. However, to provide ATC with the routing flexibility required for traffic spacing and sequencing in high density terminal areas, profile descents may not necessarily have a depicted route. In such cases, the required routing will be provided by ATC at the time the profile descent clearance is issued (usually the STAR). ATC will be providing radar vectors to the final approach course from a location depicted on the chart.

Once issued, a profile descent constitutes an ATC clearance. Acceptance of the clearance by the pilot (e.g. CLEARED PROFILE DESCENT RWY 24 VIA DIRECT TORONTO VOR) requires the pilot to adhere to all instructions depicted on the profile descent chart. However, no pilot is required to accept a profile descent clearance. A detailed clearance should be requested if any doubt exists as to the meaning.

Prior to transitioning from the en route portion of the flight to the arrival phase, ATC will clear the aircraft for the procedure:

"ALPHA BRAVO CHARLIE CLEARED PROFILE DESCENT RWY 24."

Profile descent clearances are subject to traffic conditions and may be cancelled or revised as necessary by ATC.

B. ATC REVISIONS

Any ATC *revisions to depicted altitudes cancels all* of the remaining portion of the charted procedure. ATC will then issue necessary altitude and speed restrictions. For example, a depicted restriction specifies to "cross 25 DME at and maintain 9,000 ft. at 250 KT". ATC revises the altitude to 7,000 ft. at a point prior to 25 DME:

"ALPHA BRAVO CHARLIE MAINTAIN 7,000 FT. CROSS 25 DME AT OR BELOW 9,000 FT. AT 250 KT".

A controller revision of depicted *speed instruction voids all charted speed instructions*. However, charted altitude instructions are not affected by a speed revision. ATC shall be advised if a pilot cannot comply with the charted altitude instructions due to a revised speed.

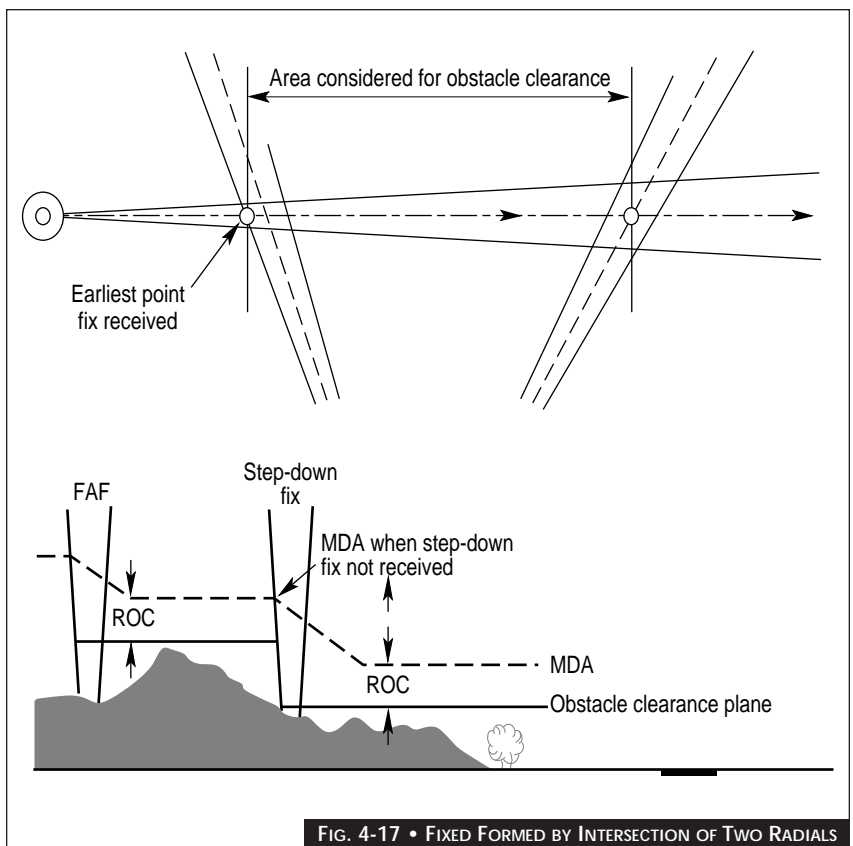

FIG. 4-17 • FIXED FORMED BY INTERSECTION OF TWO RADIALS

A profile descent clearance does not constitute authorization to fly an instrument approach procedure. The last "maintain (altitude)" specified in the profile descent procedure constitutes the last ATC assigned altitude, and the pilot must maintain such altitude until cleared for an approach unless another altitude is assigned by ATC.

**4.5.4
ADVANCE NOTICE OF INTENT IN MINIMUM WEATHER CONDITIONS**

ATC can handle missed approaches more efficiently if the controller knows the pilot's intentions in advance. They can use the extra time to plan for the possibility of a climb-out and thus provide better service in the event of an actual missed approach. When the ceiling or visibility is close to the published minima for the type of approach to be used, pilots should provide controllers with advance information as to their plans in the event of a missed approach.

IN THE EVENT OF MISSED APPROACH REQUEST (altitude or flight level) VIA (route) TO (airport).

Implementation of this procedure increases the amount of communications, but the increase can be minimized if pilots employ it only when there is a reasonable probability that a missed approach may occur.

**4.5.5
CONTROL TRANSFER**

A. IFR UNITS - TOWERS

At some point after ATC clears an aircraft for an instrument approach, ATC transfers control of the aircraft from the IFR unit to the control tower. Transfer of control to the tower does not cancel the IFR flight plan, but rather indicates that the aircraft is now receiving VFR air traffic control service.

Occasionally, the tower may issue instructions that supersede previous instructions or clearances received from the IFR unit. Acknowledgement of these instructions indicates to the tower that the pilot will comply with them. A pilot must not assume that the

control tower has radar equipment or that radar control is still being used.

B. INITIAL CONTACT WITH TOWERS

Pilots shall establish communications with the control tower as follows:

- 1/ if in direct communication with an area control centre or a terminal control unit, the IFR controller shall advise the pilot when to contact the tower; or

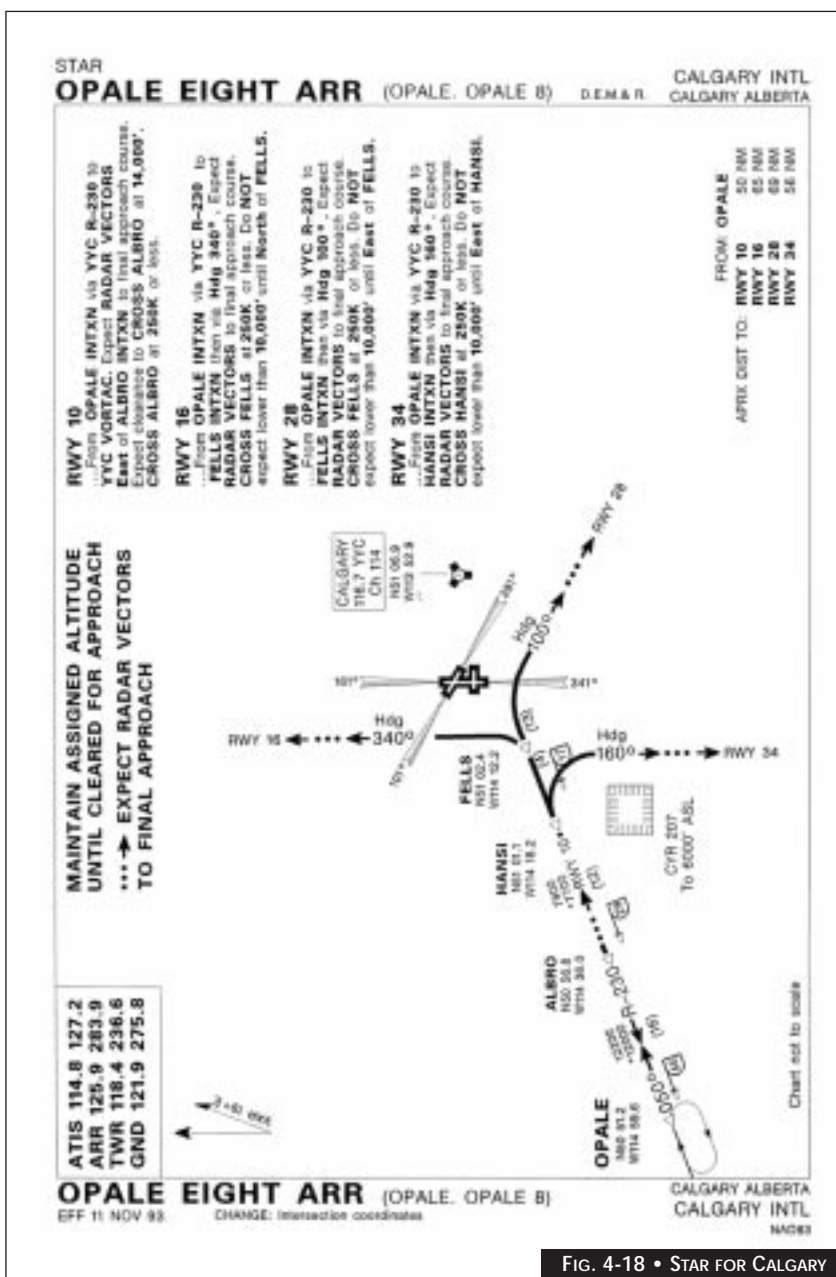

FIG. 4-18 • STAR FOR CALGARY

2/ if the conditions above do not apply, pilots shall establish communication with the tower when approximately 25 NM from the airport and shall remain on tower frequency.

4.5.6 APPROACH CLEARANCE PROCEDURES

A. GENERAL

When using direct controller-pilot communications (DCPC), ATC normally advises pilots of the ceiling, visibility, wind, runway, altimeter setting and approach aid being used, immediately prior to or shortly after descent clearance. When the pilot acknowledges receipt of the current ATIS broadcast, however, ATC advises the pilot of the current altimeter setting and RVR (if applicable) only.

Controllers issue *approach clearances* (including contact or visual approaches) only if there is a published instrument approach procedure for that airport. If there is no published approach for an airport located on an airway, ATC clears the aircraft *out of controlled airspace* and advises the "Minimum IFR Altitude". Upon reaching this altitude the pilot has the option of cancelling IFR and proceeding VFR to the airport or, if VFR conditions do not exist, proceeding on an IFR clearance to an alternate destination. Within controlled airspace, ATC is not permitted to approve or assign any IFR altitude below the "Minimum IFR Altitude". To ATC, the "Minimum IFR Altitude" is the lowest IFR altitude established for use in a specific airspace and depending on the airspace concerned this may be:

- a/ minimum en route altitude (MEA);
- b/ minimum obstruction clearance altitude (MOCA);
- c/ minimum sector altitude (see note);
- d/ geographic area safe altitude (GASA)
- e/ 100 NM safe altitude (see note); or
- f/ minimum vectoring altitude.

On an airway, altitudes below the MEA, but not below the MOCA, may be approved by a controller when specifically requested by the pilot of an IFR flight in the interest of flight safety (e.g., due to icing conditions). Pilots should note

that the required signal coverage to navigate within the airspace protected for their route may not be adequate. This could result in conflict with adjacent air traffic or collision with terrain.

NOTE:

Unless these areas are centred on a VOR/DME, TACAN, or other aid which provides distance information, pilots should be certain they are within the confines of the airway before accepting the assigned altitude.

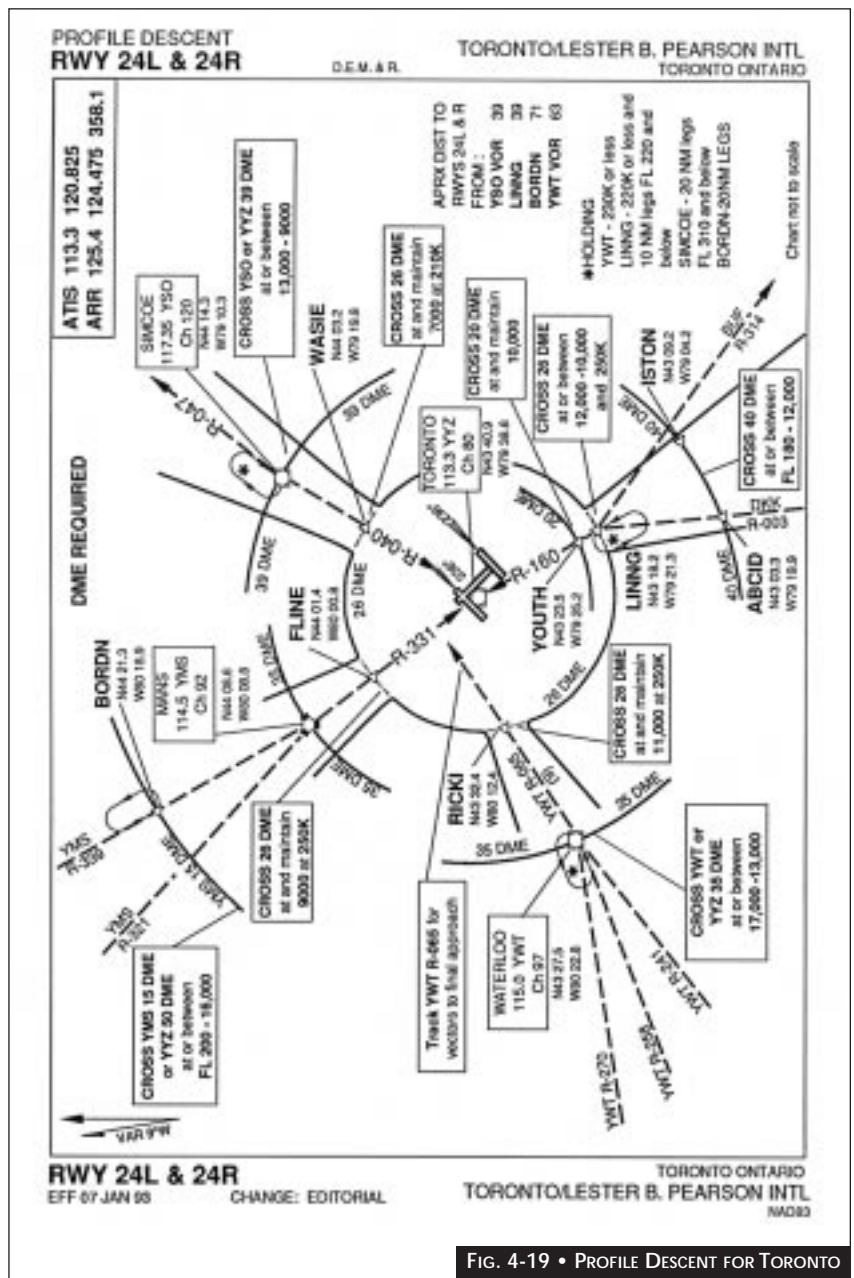

FIG. 4-19 • PROFILE DESCENT FOR TORONTO

Normally, when an approach clearance is issued, the published name of the approach is used to designate the type of approach if adherence to a particular procedure is required. If visual reference to the ground is established before completion of a specified approach, the aircraft should continue with the entire procedure unless further clearance is obtained.

EXAMPLE:

CLEARED TO THE OTTAWA AIRPORT,
STRAIGHT-IN ILS RUNWAY 07
APPROACH.

EXAMPLE:

CLEARED TO THE TORONTO AIRPORT,
ILS RUNWAY 06 LEFT APPROACH.

The number of the runway on which the aircraft will land is included in the approach clearance when a landing will be made on a runway other than that aligned with the instrument approach aid being used.

EXAMPLE:

CLEARED TO THE PRINCE GEORGE
AIRPORT, STRAIGHT-IN ILS RUNWAY 15
APPROACH CIRCLING PROCEDURE
WEST FOR RUNWAY 06.

NOTE:

If the pilot begins a missed approach during a circling procedure, the published missed approach procedure as shown for the instrument approach just completed must be flown. The pilot does not use the procedure for the runway on which the landing was planned.

At some locations during periods of light traffic, controllers may issue clearances that do not specify the type of approach.

EXAMPLE:

CLEARED TO THE LETHBRIDGE
AIRPORT FOR AN APPROACH.

As soon as practicable after receipt of this type of clearance, the pilot should advise ATC of the type of approach procedure to be flown, *as well as the route of flight*. The route may be either the previously cleared route, a transition, or from any position along the previously cleared route of flight directly to a fix from which a

published instrument approach can be carried out. Pilots may not deviate from the stated instrument procedures or declared route without the concurrence of ATC.

Since contact approaches and visual approaches are not instrument approaches, the pilot does not have an option of carrying out either of these approaches based solely on the clearance "CLEARED FOR AN APPROACH." Should the pilot wish to conduct a contact or visual approach, a request must be made to the controller.

On occasion a clearance for an approach may *not include altitude instructions*. The pilot may receive this clearance while the aircraft is still a considerable distance from the facility, in either a radar or non-radar environment, and within or outside controlled airspace. In these cases the pilot can descend to an *appropriate minimum IFR altitude* (refer to Article 3.3.2A).

Having determined the minimum altitude that provides the required obstacle clearance, the pilot may descend to this altitude when desired. Pilots are cautioned that descending early to a 100 NM safe or minimum sector altitude may take the aircraft out of controlled airspace.

NOTE:

In designated mountainous regions outside areas having a published minimum altitude, the pilot must use 1,500 ft or 2,000 ft above the highest obstacle within a horizontal radius of 10 NM from the established position of the aircraft. Article 4.3.2C refers.

Where a published minimum IFR altitude is above the base of controlled airspace and a destination aerodrome is outside controlled airspace ATC may clear an aircraft to descend out of controlled airspace via a published instrument approach procedure.

EXAMPLE:

ATC CLEARS GABC OUT OF
CONTROLLED AIRSPACE VIA THE NDB
"A" APPROACH AT KINCARDINE.

B. STRAIGHT-IN APPROACHES

ATC uses the term "straight-in-approach" to indicate an instrument approach wherein the



pilot begins a final approach without first executing a procedure turn. Straight-in approaches are approved when published on the instrument approach chart (*No PT* or a note authorizing straight-in approaches) or when aircraft are radar-vectored by ATC to a point where a straight-in approach may be commenced and where ATC clearance for a straight-in approach has been given. If none of these conditions are met, an aircraft flying IFR *must conduct a procedure turn or a visual or contact approach*. Minimum IFR altitudes or higher must be maintained during straight-in approaches until it is appropriate to follow altitudes published on the instrument approach chart. It is vital that *pilot intentions* be transmitted to ATS or to other pilots on the appropriate frequencies so that conflicts do not arise.

C. VISUAL—CONTACT APPROACHES

1. *VISUAL APPROACH*: A visual approach is an approach wherein a pilot on an IFR flight plan, operating in VFR weather conditions under the control of an air traffic control facility and having an air traffic control authorization, may proceed to the airport of destination in VFR weather conditions.

In a *radar environment*, to gain operational advantages, the controller may request a radar-vectored flight to accept a visual approach clearance, provided that:

- a/ the reported ceiling is at least 500 ft. above the established minimum vectoring altitude and the ground visibility is at least five statute miles; and
- b/ the pilot reports sighting the airport or any traffic from which he or she will be maintaining visual separation.

The controller considers acceptance of a visual approach clearance as acknowledgement that the pilot shall provide his or her own wake turbulence separation. Adherence to published noise abatement procedures and compliance with any restrictions that may apply to Class F airspace are the pilot's responsibility.

ATC will not issue specific missed approach

instructions. Aircraft on a missed visual approach are considered as operating under VFR.

2. *CONTACT APPROACH*: A contact approach is an approach wherein a pilot on an IFR flight plan, having an air traffic control authorization, operating clear of clouds with at least 1 mile flight visibility and a reasonable expectation of continuing to the destination airport in those conditions, may *deviate from the instrument approach procedure* and proceed to the destination airport by visual reference to the surface of the earth.

This type of approach will only be authorized by ATC when:

- a/ the pilot requests it;
- b/ reported ground visibility is at least 1 mile; and
- c/ traffic conditions permit.

When executing a contact approach, obstruction clearance, adherence to published noise abatement procedures and compliance with any restrictions that may apply to Class F airspace are the pilot's responsibility. ATC will ensure IFR separation from other IFR flights and will issue specific missed approach instructions.

NOTE:

ATC will not issue an IFR approach clearance which includes clearance for a contact approach, unless there is a published instrument approach procedure or a company instrument approach procedure authorized by Transport Canada for the airport.

D. POSITION REPORTS

Position reports required for IFR aircraft during approaches to uncontrolled airports are outlined in Article 3.4.3(E). *At controlled airports*, pilots are to make position reports by stating the aircraft call-sign and position *only when requested by ATC*. Pilots can expect a request from ATC for a report either at the FAF or a specified distance on final.

To apply the prescribed separation minima between aircraft intending to make a complete instrument approach and other aircraft at non-

radar airports, ATC must often establish the position and direction of arriving aircraft with respect to the approach facility. When requested to *report "outbound"* at controlled airports, pilots should make these reports only after they are over or abeam the approach facility, and proceeding in a direction away from the airport.

E. MISSED APPROACH INSTRUCTIONS

In the event of a missed approach when no missed approach clearance has been received, the pilot will follow the *published* missed approach instructions. Should the pilot arrive at the missed approach holding fix prior to receiving further clearance, the pilot will:

- 1/ hold in a standard holding pattern on the inbound track used to arrive at the fix; or
- 2/ if there is a published missed approach track to the fix, hold in a standard holding pattern inbound to the fix on this track; or
- 3/ if there is a published shuttle or holding pattern at the fix, hold in this pattern regardless of the missed approach track to the fix; or
- 4/ if there are published missed approach holding instructions, hold in accordance with these.

If a clearance to another destination has been received, the pilot shall, in the absence of other instructions, carry out the published missed approach instructions until at an altitude which will ensure adequate obstacle clearance before proceeding on course.

If specific missed approach instructions have been received and acknowledged, the pilot is required to comply with the new missed approach instructions before proceeding on course, e.g., ON MISSED APPROACH, CLIMB RUNWAY HEADING TO 3,000 FT.; RIGHT TURN, CLIMB ON COURSE" OR "ON MISSED APPROACH, CLIMB STRAIGHT AHEAD TO THE BRAVO NDB BEFORE PROCEEDING ON COURSE.

Air traffic control procedures *do not* require the air traffic controller to provide terrain and obstacle clearance in their missed approach instructions. It remains the pilot's responsibility to ensure that terrain and obstacle clearance has been achieved.

F. SPEED ADJUSTMENTS - RADAR CONTROLLED AIRCRAFT

This section describes directives to controllers and in no way alters the following *maximum speeds*:

- 1/ below 10,000 ft. ASL and within controlled airspace, 250 knots for all aircraft; and
- 2/ below 3,000 ft. AGL and within 10 NM of controlled airports, 200 knots for all aircraft.

To supplement or minimize radar vectoring ATC may have to request speed adjustments. While ATC takes every precaution not to request speeds beyond the capability of the aircraft, the pilot still must ensure that the aircraft is not operated at a speed below the safe manoeuvring speed. If an ATC unit should request a speed reduction below the aircraft's safe manoeuvring speed, the pilot should inform ATC that he or she is unable to comply. Speed adjustment requests are expressed in multiples of 10 kts based on indicated airspeed. Pilots complying with speed adjustment requests are expected to maintain a speed within plus or minus 10 kts of the specified speed.

PHRASEOLOGY:

MAINTAIN PRESENT SPEED

MAINTAIN (specified speed) KNOTS

INCREASE SPEED TO (specified speed) KNOTS

REDUCE SPEED TO (specified speed) KNOTS

INCREASE SPEED BY (number) KNOTS

REDUCE SPEED BY (number) KNOTS

Pilots may be requested to do one of the following:

- 1/ maintain present speed; or
- 2/ increase/reduce speed to a specified speed or by a specified amount.

Unless prior concurrence in the use of a lower speed is obtained from the pilot, the following *minimum speeds* will be applied for aircraft during radar vectoring:

- 1/ for aircraft operating *20 miles or more* from destination airport, and
 - i/ at or above 10,000 ft. ASL: - 250 KTS IAS.



ii/ below 10,000 ft. ASL: - 210 KTS IAS.

2/ for *turbojet* aircraft operating *less than 20 miles* from destination airport: - 160 KTS IAS.

3/ for *propeller-driven* aircraft operating *less than 20 miles* from destination airport: - 120 KTS IAS.

Issuance of an *approach clearance normally cancels a speed adjustment*; however, if the controller requires that a pilot maintain a speed adjustment after issuance of the approach clearance, the controller will restate it. In other cases the air traffic controller should instruct the pilot to resume normal speed.

G. TAXIING

After landing on a dead-end runway, an aircraft normally receives clearance to taxi back along the runway in use (back-track). When a taxi strip or turn-off point is available ahead, the aircraft should promptly clear the runway at this point. Unless otherwise instructed by the tower, and after clearing the runway, the aircraft shall continue to taxi forward to a point at least 200 ft from the runway, (or beyond the "hold" line), before stopping if post landing checks are required. When required, instructions for clearing the runway are:

EXAMPLE:

Tower: CF-ABC (instructions for clearing runway) CONTACT GROUND CONTROL (specific frequency) NOW or AT (specific location).

Towers normally provide the aircraft with down time only when the pilot requests it.

Normally aircraft are not changed to ground control until clear of the active runway.

When clear of the runway in use, taxi clearance is given as follows:

EXAMPLE:

Tower: ABC CLEARED TO (Apron or parking area) (any special instructions such as routing, cautionary or warning regarding construction or repair on the manoeuvring areas).

4.5.7

APPROACH AND ALTERNATE MINIMA

A. APPROACH BAN

With certain exceptions, pilots of all aircraft are prohibited from completing any instrument approach past the outer marker or Final Approach Fix to a runway served by an RVR when the RVR values as measured for that runway are below the following minima:

MEASURED RVR*	FIXED WING	ROTORCRAFT
RVR "A" ONLY	1200	1200
RVR "A" & "B"	1200 / 700	1200 / 0
RVR "B" ONLY	1200	1200

* RVR "A" located adjacent to the runway threshold
* RVR "B" located adjacent to the runway mid-point

The following *exceptions* to the above prohibitions apply to all aircraft:

- a/ when the RVR is received, the aircraft is inbound on final approach and has passed the Final Approach Fix;
- b/ the pilot-in-command has informed ATS that the aircraft is on training flight and will initiate a missed approach at or above the DH/MDA;
- c/ the RVR is fluctuating rapidly above and below the minimum RVR; or
- d/ the RVR is below the minimum RVR because of a localized phenomenon and the ground visibility of the aerodrome as reported by ATS is at least 1/4 SM.

With respect to approach prohibitions, exceptions are allowed due to RVR "*fluctuations*" or "*local phenomenon*" effects.

In summary, *an approach is authorized* whenever:

- a/ the lowest reported RVR for the runway is at or above minima regardless of reported ground visibility;
- b/ RVR for the runway is reported fluctuating above and below minima, regardless of reported ground visibility;
- c/ a reported ATC/FSS ground visibility is at least 1/4 SM, regardless of reported RVR

- for the runway;
- d/ RVR for the runway is unavailable or not reported; or
- e/ ATIS is informed an aircraft is on a training flight and will conduct a planned missed approach.

NOTE:

The General section of CAP or AIP RAC should be consulted for current information on minima. The above information is current only to the time of printing of this manual.

B. LANDING MINIMA

Air Regulations specify that landings are governed by published DH/MDAs. Pilots of aircraft on instrument approaches are prohibited from continuing the descent below DH, or descending below MDA, as applicable, unless the required visual reference is established and maintained, in order to complete a safe landing. When the required visual reference is not established or maintained, a missed approach must be initiated. Missed approaches initiated before or beyond the MAP may not be assured obstacle clearance.

1. **VISUAL REFERENCES:** The visual references required by the pilot in order to continue the approach to a safe landing shall include at least one of the following references for the intended runway and should be *distinctly visible and identifiable* to the pilot:
 - a/ the runway or runway markings;
 - b/ the runway threshold or threshold markings;
 - c/ the touchdown zone or touchdown zone markings;
 - d/ the approach lights;
 - e/ the approach slope indicator system;
 - f/ the runway identification lights (RILS);
 - g/ the threshold and runway end lights;
 - h/ the touchdown zone lights;
 - i/ the parallel runway edge lights; or
 - j/ the runway centreline lights.

Published landing visibilities associated with all instrument approach procedures are advisory only. Their values are indicative of visibilities which, if prevailing at the time of approach, should result in the required visual

reference being established and maintained to landing. They are not limiting and are intended to be used by pilots only to judge the probability of a successful landing when compared against available visibility reports at the aerodrome to which an instrument approach is being carried out.

2. **ALTIMETER SETTING REQUIREMENTS:** Before commencing an instrument approach procedure, the pilot shall have set on the aircraft altimeter a current altimeter setting usable for the location where the approach is to be flown. The altimeter setting may be a local setting or a remote setting when so authorized on the instrument procedure chart. A current altimeter setting is one provided by approved direct reading or remote equipment, or by the latest routine hourly weather report. These readings are considered current up to 90 minutes from the time of observation.

CAUTION:

Care should be exercised when using altimeter settings older than 60 minutes or when pressure has been reported as falling rapidly. In these instances a value may be added to the published DH/MDA in order to compensate for falling pressure tendency (0.01 inches mercury = 10 feet correction).

3. **USE OF STRAIGHT-IN MINIMA:** The use of a straight-in minima is predicated upon the weather and runway condition reports required to conduct a safe landing. Where the pilot lacks any necessary information, the pilot is expected to make an aerial visual inspection of the runway prior to landing. In some cases, this can only be accomplished by conducting a circling approach utilizing the appropriate circling MDA.

Runway conditions, including any temporary obstructions such as vehicles, may be determined by the pilot by:

- a/ contacting the UNICOM at the destination;
- b/ a pre-flight telephone call to the destination to arrange for making the necessary information available when required for landing;

- c/ an aerial visual inspection;
- d/ NOTAM issued by the airport operator; or
- e/ any other means available to the pilot, such as message relay from preceding aircraft at destination.

Pilots must always ensure that the runway is not obstructed and verify the wind direction before landing.

Regardless of wind direction or runway in use, pilots of *rotorcraft* may use the appropriate published straight-in landing minima for the runway they have selected for their approach.

C. ALTERNATE MINIMA

All IFR flights - except those operators approved for "no-alternate IFR" in their Operations Specifications - require a filed alternate airport. See *AIP RAC* for the current alternate minima requirements.

Authorized *weather minima* for alternate aerodromes are specified on Aerodrome Charts and are predicated on an Aerodrome Forecast (FT) or an Area Forecast (FA). The minima used for an alternate aerodrome shall be consistent with aircraft performance, navigation equipment limitations, type of weather forecast, and runway to be used. Pilots of rotorcraft are permitted to use the *CAP* alternate ceiling and one-half the *CAP* alternate visibility (but no less than 1 SM) when selecting an alternate aerodrome.

Alternate minima lower than those in the table below may be approved in the Operations

Specifications of some operators.

Due to inconsistencies in the relationship of aviation forecast visibility values and the published or calculated alternate visibility values, the following correlation is to be used to determine acceptable alternate visibility minima for civil operations:

PUBLISHED OR CALCULATED VALUE	USE FORECAST VALUE
13/4	2 SM
21/4	2 SM
23/4	3 SM

When selecting an alternate aerodrome, where an Aerodrome Forecast or Terminal Advisory is not available, the Area Forecast covering the specified alternate aerodrome may be used. The *Area Forecast* for the time of arrival must indicate meteorological conditions of:

- a/ no cloud below the minimum alternate ceiling specified in the *CAP*;
- b/ no cumulonimbus; and
- c/ a visibility of 3 statute miles or more.

In *Aerodrome Forecasts* (FTs), the terms OCNL and RISK may be used to determine the weather suitability of an aerodrome as an alternate provided the forecast OCNL or RISK condition is not below the appropriate *landing minima* for that aerodrome.

NOTE:

All heights specified in Area Forecasts are ASL unless otherwise indicated.

ALTERNATE WEATHER MINIMA REQUIREMENTS TABLE		IF STANDARD IS APPLICABLE, THE FOLLOWING MINIMA ALSO AUTHORIZED		STANDARD ALTERNATE MINIMA	
FACILITIES AVAILABLE AT SUITABLE ALTERNATE	WEATHER REQUIREMENTS	CEILING	VISIBILITY	CEILING	VISIBILITY
2 or more useable precision approaches each providing straight-in minima to separate suitable runways	400-1 or 200-1/2 above the lowest useable minima, whichever is greater	700	11/2	600	2
one useable precision approach	600-2* or 300-1 above the lowest useable minima, whichever is greater	800	1		
non-precision only available	600-2* or 300-1 above the lowest useable minima, whichever is greater	900	11/2	800	2
no IFR approach available	Forecast weather must be no lower than 500 feet above a minimum IFR altitude that will permit a VFR approach and landing	1000	1		
* 600-2 & 800-2, AS APPROPRIATE, ARE CONSIDERED TO BE STANDARD ALTERNATE MINIMA. SHOULD THE SELECTED ALTERNATE WEATHER REQUIREMENTS MEET THE STANDARD MINIMA, THEN THE FOLLOWING MINIMA ARE ALSO AUTHORIZED:		NOTE 1: THE ABOVE REQUIREMENTS ARE PREDICATED UPON THE AERODROME HAVING AN AERODROME FORECAST OR TREND FORECAST AVAILABLE. NOTE 2: AERODROMES SERVED WITH A TERMINAL ADVISORY FORECAST MAY QUALIFY AS AN ALTERNATE PROVIDED THE FORECAST WEATHER IS NO LOWER THAN 500 FEET ABOVE THE LOWEST USEABLE HAT/HAA AND THE VISIBILITY IS NOT LESS THAN 3 MILES.			

Where an Aerodrome Forecast is available part-time only, two values will be published.

EXAMPLE:

Sumspot, N.W.T.

Note on the Aerodrome Chart to read:

+Predicated on an Area Forecast.

See Alternate minima,

General Information section.

MINIMA	ALTERNATE	† 1800 - 3	VISIBILITY
		800 - 2	(SM)
CEILING (AGL)			

4.5.8 AIRCRAFT CATEGORIES

Transport Canada's obstacle clearance, take-off requirements, descent gradient and visibility requirements, particularly as they relate to non-precision procedures and circling, are designed to accommodate various types of aircraft. Aircraft that are manoeuvred within these category speed ranges are to use the appropriate instrument approach minima for that category. For instance, an aircraft that is normally flown at 110 kts on approach but is flown at 125 kts due to gusty winds would use the minima published for Category C.

The categories are referred to by letter:

CATEGORY A	-	UP TO 90 KT. (INCLUDES ROTORCRAFT);
CATEGORY B	-	91 TO 120 KT.;
CATEGORY C	-	121 TO 140 KT.;
CATEGORY D	-	141 TO 165 KT..

All manoeuvring procedures relate to aircraft operational characteristics. Pilots should comply with the information shown on instrument approach charts to keep aircraft within the areas provided for obstacle clearance. Minima vary according to the aircraft category.

4.5.9 CORRECTIONS FOR TEMPERATURE

Cold temperature corrections are extremely important for safe IFR flight in Canadian

winters. Fig. 4-20 is extracted from the CAP and shows that corrections should be made to all altitudes published on the instrument approach chart.

4.5.10 REMOTE ALTIMETER SETTING

Normally, approaches shall be flown using the current altimeter setting only for the destination aerodrome. However, at certain aerodromes where a local pressure setting is not available, approaches may be flown using a current

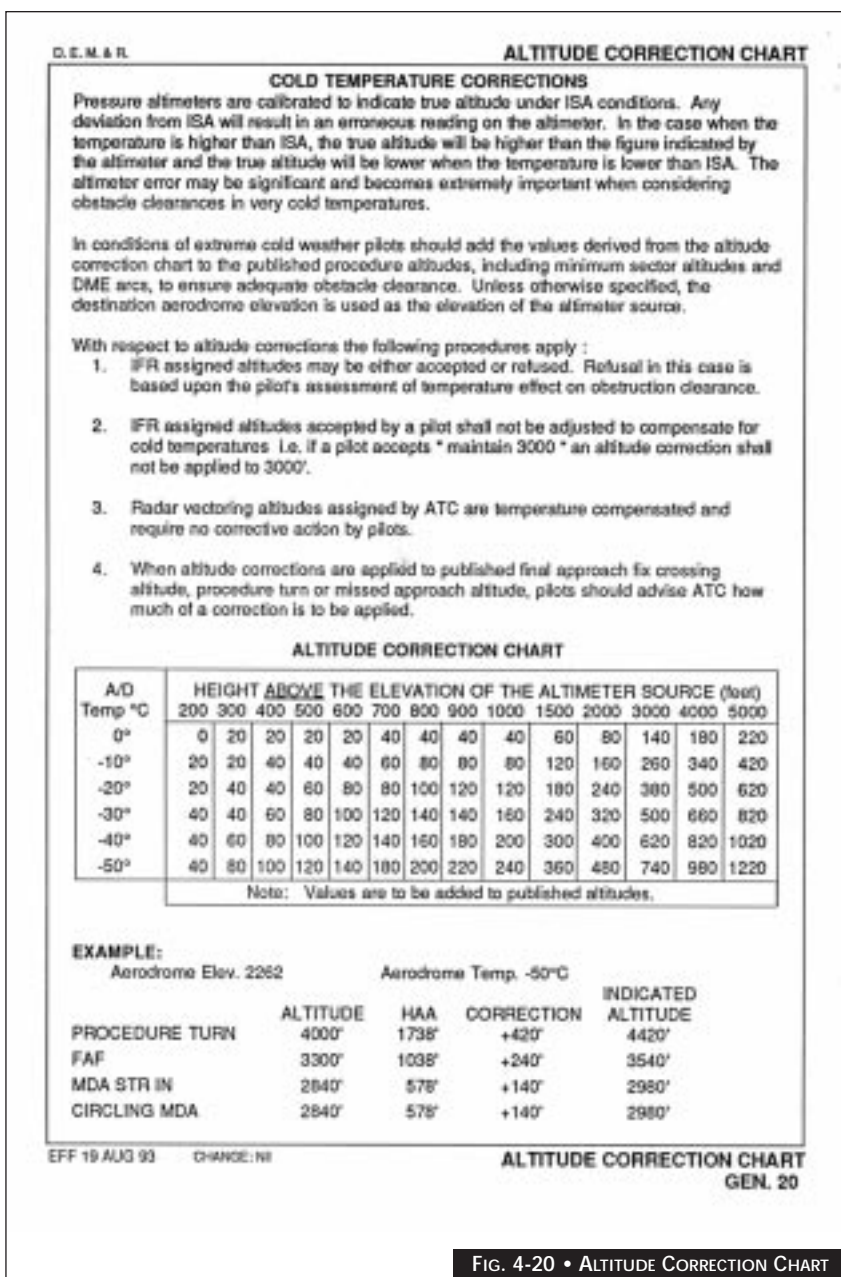

FIG. 4-20 • ALTITUDE CORRECTION CHART

altimeter setting for a nearby aerodrome. Such an altimeter setting is considered a "remote altimeter setting", and authorization for its use is published on the approach chart plan view. (Fig. 4-21).

If the use of a remote altimeter setting is required for *limited hours only*, an altitude correction will be included with the authorization. When the remote altimeter setting is used, the altitude correction shall be applied as indicated. If the use of a remote altimeter setting is required at all times, then the correction is incorporated into the procedure at the time it is developed.

EXAMPLES:

When using Mont Joli altimeter setting add 200' to FAF crossing altitude and all MDAs.

London altimeter setting must be obtained before commencing IFR procedure.

4.5.11

TRANSITIONS TO THE APPROACH

A. RADAR VECTORS

Radar separation is applied to arriving aircraft in order to establish and maintain the most desirable arrival sequence to avoid unnecessary "stacking" or delays. In the approach phase, radar vectoring is carried out to establish the aircraft on an approach aid. The initial instruction is normally a turn to a heading for radar vectors to a final approach to the runway in use. Should a communications failure occur after this point, the pilot should continue and carry out a straight-in approach if able, or carry out a procedure turn and land as soon as possible. Aircraft are vectored so as to intercept the final approach course approximately 2NM from the point at which final descent will begin.

EXAMPLE:

JULIETT WHISKEY CHARLIE, ARRIVAL. TURN LEFT HEADING 180 TO INTERCEPT FINAL APPROACH COURSE. CLEARED TO THE TORONTO AIRPORT FOR STRAIGHT-IN ILS RUNWAY 15 APPROACH.

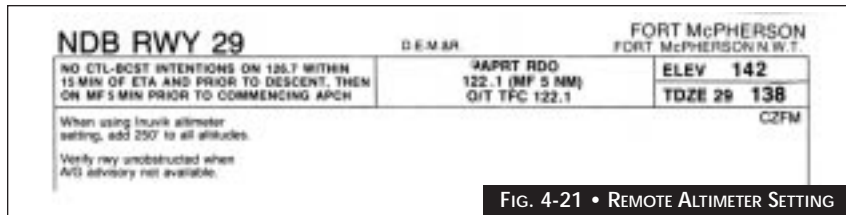

FIG. 4-21 • REMOTE ALTIMETER SETTING

B. ON AIRWAYS

The airway may be based on the approach facility. In this case the aircraft can descend to the airway minimum en route altitude (MEA) or the procedure turn altitude, whichever is higher, and cross the procedure turn facility outbound at that altitude.

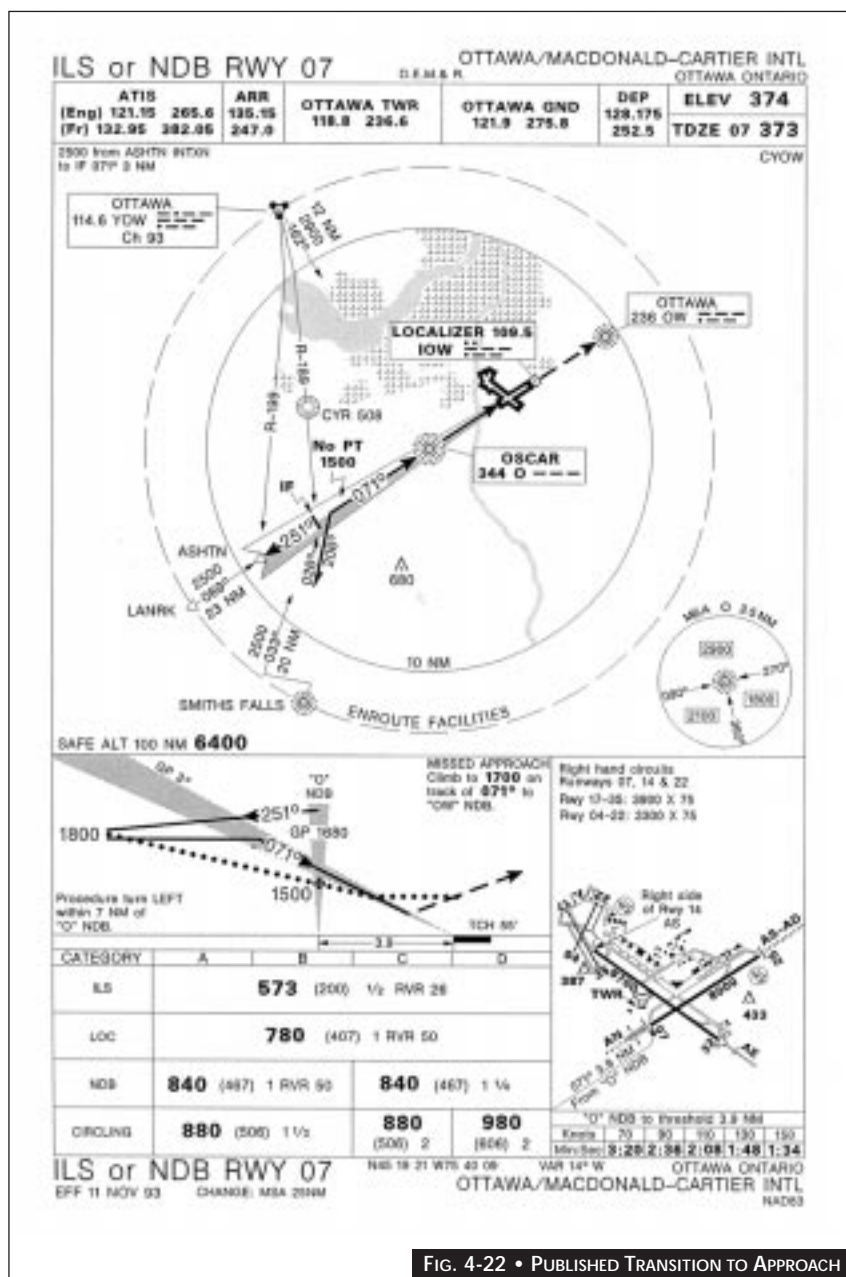

FIG. 4-22 • PUBLISHED TRANSITION TO APPROACH

The airway may lead to a terminal area facility or fix from which a *published transition* is shown on the approach chart, leading to the approach facility (e.g., 2900 from Ottawa VORTAC to OSCAR NDB for ILS 07 - Ottawa Fig. 4-22).

C. OFF AIRWAYS

Until established on a low-altitude airway or published transition, the pilot is responsible for obstacle clearance.

D. ARC TRANSITIONS

Normally the arc transition leads the aircraft to a point on the approach track for a straight-in approach. Often a *lead radial* is used to allow for a smooth transition to the final approach course. Only that portion of the arc shown on the chart can be flown at the minimum transition altitude designated for the arc. This altitude *must* be maintained until established at a point on the final approach track where the profile view authorizes further descent in the final approach phase. (See Fig. 4-23).

4.5.12 APPROACH PLANNING

Careful pre-approach planning and good instrument flying are essential for safe, effective approaches in IFR weather. Occasionally, an unexpected event may cause a momentary distraction, or may develop into an emergency situation demanding prompt attention. There are many different situations that can arise during an approach; nevertheless, any unexpected event becomes easier to deal with when the pilot has planned the approach thoroughly.

Approaches should be planned well in advance. Planning starts before take-off and is continued during the flight while the pilot is examining the approach charts and *updating destination and alternate weather conditions*. The following information is *essential to planning*.

- 1/ the arrival clearance and destination weather;
- 2/ the position of the aircraft relative to the facility;

- 3/ the wind strength and direction, particularly at the surface;
- 4/ the runway-in-use which, when combined with the wind information, determines whether straight-in or circling minima apply;
- 5/ the published minimum altitude for the required procedures;
- 6/ the airspeed targets and limitations during the procedure turn and on final;
- 7/ the type of procedure turn to be used so that the aircraft will remain within the designated airspace;
- 8/ the distance from the facility to the MAP;
- 9/ the rates of descent required during various stages of the approach (particularly from the facility to the field during non-precision approaches);
- 10/ the time from the facility to the "Missed Approach Point" - remember that the speeds on the approach chart are groundspeeds, so the pilot must apply the wind to the TAS or IAS before computing the time to the MAP;
- 11/ the type of circling procedure to be used (if applicable);
- 12/ the missed approach procedure;
- 13/ the NAVAIDS to be used during the approach and missed approach procedure; and
- 14/ the aural monitoring of the NDB by the pilot or one of the flight crew members, if flying an NDB approach (non-FMS equipped aircraft only).

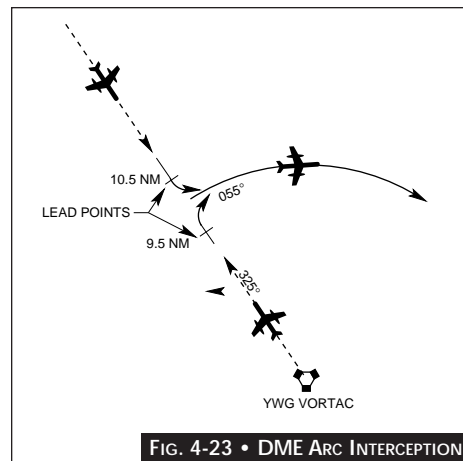

FIG. 4-23 • DME ARC INTERCEPTION

A thorough *approach briefing* to all crew members (if a multi-crew cockpit) will serve two purposes. One, it will advise everyone concerned what you as pilot intend to do and will make it easier for them to detect any errors. Two, it gives you a chance to verbalize the important points of the approach, clarifying them in your mind.

There may be some advantage in doing part of the pre-landing check before initial station passage outbound, thus reducing distractions and allowing full concentration on flying. All



checks must be done in accordance with the appropriate Aircraft Operating Manual; therefore, when checks are split for convenience, the pilot must ensure that they are completed correctly.

There is only limited time available for receiving further clearance after a missed approach procedure. If the weather seems to be increasing the possibility of a missed approach, the pilot should notify the controlling agency of intentions which could include the route and altitude to the alternate. This notification is of particular value if communications are lost or delayed during the approach.

4.6 INSTRUMENT APPROACH PROCEDURES

4.6.1 INTRODUCTION

In the departure and en route phases of IFR flight, the pilot steadily climbs to a safe altitude and thereafter maintains a margin of safety at the cruising altitude, which is at or above the MEA for the route segment.

The IFR pilot draws on a complete range of skills and experience when descending to the destination. The aircraft height above obstacles during IFR flight reduces in stages to zero at the point of touchdown. Most of this descent may be in cloud, with only the last few hundred feet in visual conditions - often with visibility of $1/2$ mile or less.

The descent from en route to touchdown cannot yet be made in one continuous profile, although the abilities of area navigation, radar vectoring and straight-in procedures are close to permitting such a profile. Pilots must still contend with level-offs, speed reductions and aircraft configuration changes even in the best organized terminal areas.

Transport Canada develops instrument approach procedures according to TP 308, *Criteria for the Development of Instrument Procedures*. Approaches are designed to satisfy the minimum performance and equipment requirements. Each procedure consists of segments that are intended to indicate to the pilot when to descend, when to reduce speed, when to configure the aircraft for landing, and when to carry out a missed approach if the pilot is not in visual contact at minimum altitude.

Each *segment of the approach* has a purpose and entails certain cockpit duties. The procedure designer attempts to construct the approach using the four basic segments to give the pilot time to control the aircraft, bleed off speed, and at the same time lose altitude, so as to arrive at the runway with the gear and flaps down and the speed on target.

The four segments of an approach are explained, mainly from the operating point of view, in Article 4.6.2.

Instrument approach procedures are developed by Transport Canada and published in *The Canada Air Pilot*, and by third party vendors such as *Jeppesen*. The procedures, developed for specific airports after careful analysis of obstructions, terrain features and navigational facilities, outline the appropriate manoeuvres, including altitudes, tracks and other limitations. They are established for a safe letdown during instrument flight conditions based on accepted obstacle clearance requirements and many years of experience.

WARNING:

No attempt is made in this manual to explain the symbols and legends used on approach plates, aerodrome charts, departure, arrival and en route charts. It is the pilot's responsibility to thoroughly understand these symbols and legends and their use.

A. NON-PRECISION APPROACHES (NPA)

A descent in an approved procedure in which final approach course alignment is provided. NPAs include NDB, VOR, LOC, LOC(BC) and certain RNAV approaches. No vertical guidance is provided on an NPA.

B. PRECISION APPROACHES

A descent in an approved procedure where the navigation facility alignment is normally on the runway centreline and vertical guidance is provided. ILS, MLS and Precision Approach Radar (PAR) are precision approaches.

Simultaneous approaches is a procedure which provides for approaches to parallel or converging runways. This procedure typically uses two ILS-equipped parallel runways (24L and R at Toronto). Simultaneous approaches, when authorized, are radar monitored.

4.6.2 THE INSTRUMENT APPROACH PROCEDURE

A. PROCEDURE CONSTRUCTION

An instrument approach procedure may have four separate segments: *initial*, *intermediate*,

final and *missed approach*. In addition, an area for circling the aerodrome under visual conditions is provided. Fig. 4-24 gives a view of typical approach segments. "R" denotes the *primary area* which has the following obstacle clearance:

• initial	• 1,000 ft.
• intermediate	• 500 ft.
• final	• varies with facility
• circling	• 300 ft.
• missed approach	• increasing to en route or holding

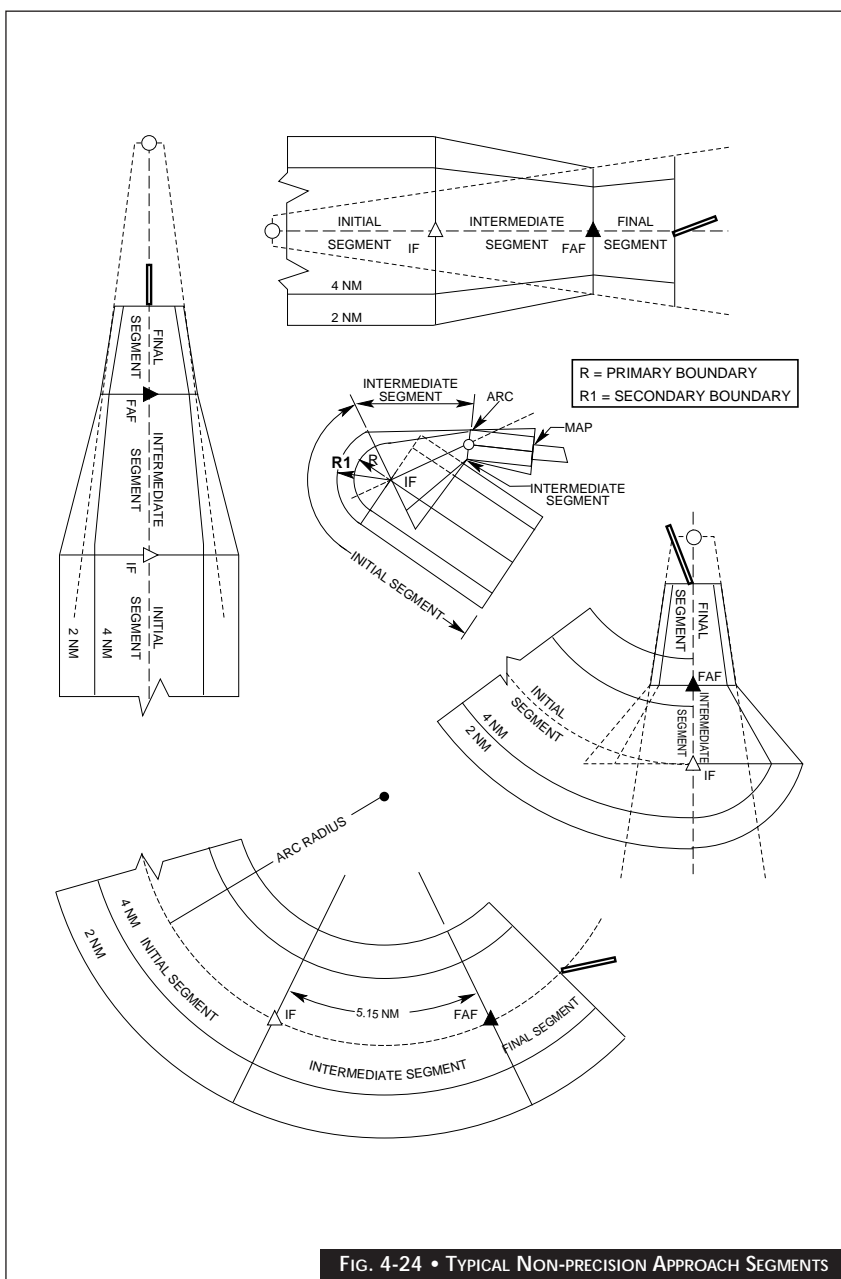

FIG. 4-24 • TYPICAL NON-PRECISION APPROACH SEGMENTS

"R₁" denotes the *secondary area* where the obstacle clearance is less.

Each of the approach segments normally begin and end at designated fixes. Under some circumstances, however, certain segments may begin at specified points where no facility is available, e.g., the final approach segment of a precision approach may originate at the intersection of the designated intermediate flight altitude with the normal glide path. A VOR final approach may commence at an intersection or DME distance.

The procedure design depends on the type and siting of navigational aids, their location in relation to the runway or aerodrome, the terrain, and the categories of aircraft to be accommodated. Airspace restrictions may also have to be considered in relation to the navigational aids. Wherever possible, the approach procedure specifies minima for *straight-in* and *circling*. Where this is not practicable, the procedure specifies circling limits only.

Normally the navigation aids align the straight-in approach with the runway centreline. Non-precision straight-in approaches also may be specified if the final approach track and the runway centreline do not diverge by more than 30° (Fig. 4-25). A straight-in approach also may be specified in certain situations where the final approach track does not intersect the extended runway centreline (or does not intersect at a suitable point), as long as the final approach track is within 500 ft. laterally of the extended runway centreline at a distance of 3,000 ft. from the threshold.

Straight-in minima are not published when the descent gradient between the published minimum crossing altitude at the Final Approach Fix and the runway threshold exceeds 400 ft./NM or 3.76°.

B. INITIAL SEGMENT

The instrument approach commences at the Initial Approach Fix (IAF, Fig. 4-26). In the initial segment, the aircraft has departed the en route structure and manoeuvres to enter the intermediate segment. Aircraft speed and configuration depend on the distance from the aerodrome, and rate of descent required. The

initial approach segment ends at the *Intermediate Fix*.

Terminal radar is a suitable alternative to published transitions or initial approach segments. The aircraft is vectored to a fix, or onto the intermediate approach track, at a point where the approach may be continued by the pilot through reference to the instrument approach chart.

Occasionally a pilot may receive clearance for an approach *without altitude restrictions*. This clearance may be issued while the aircraft is still a considerable distance from the approach facility. Several transition procedures may apply, depending on the aircraft's location and the chart information. These transitions, outlined in Article 4.5.11, are designed to position the aircraft over an approach facility or on the final approach course.

MINIMUM SECTOR ALTITUDES (MSA)

Minimum sector altitudes are normally based on the procedure turn facility and should not be used unless the aircraft position is known by reference to a fix or facility. The DME source may be some distance from the centre of the minimum sector circle, therefore, the DME distance may not always correlate with the minimum sector altitudes.

C. INTERMEDIATE SEGMENT

This segment connects the initial and final approach segments. Both the lateral dimensions of the airspace and the obstacle clearance begin to reduce. The pilot should adjust aircraft speed

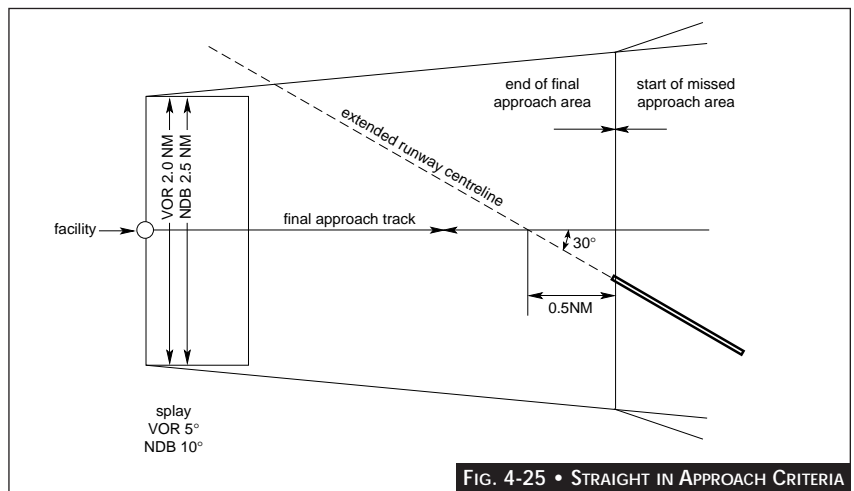

FIG. 4-25 • STRAIGHT IN APPROACH CRITERIA

and configuration to prepare for descent in the final approach. For this reason the descent gradient in the intermediate approach segment is established at 300 ft/NM maximum.

The availability of VOR and DME at most major airports permits a variety of intermediate fixes to be designated. Improvements in basic avionics packages mean that most aircraft can now make the straight-in approach. Pilots will find more and more procedures with designated IFs (*Intermediate Fix*) that require more than one navigation radio in the aircraft. The procedure turn barbed arrow, however, will still be depicted for pilots without sufficient navigational equipment for the straight-in transition, or for pilots who wish to conduct procedure turns.

In some cases the transitions are arcing transitions to the Intermediate Fix, based on the use of distance measuring equipment (DME). (Refer to Article 2.2.4D). The minimum altitude to be maintained while flying the DME arc is shown on the plan view of the instrument approach procedure chart (Fig. 4-36). This altitude provides a minimum of 1,000 ft of obstacle clearance within 4 NM of the arc. *Lead radials* approximately 10° of arc (2 NM) from the final approach course are shown to assist pilots in intercepting the final approach course.

Pilots should not fly arc transitions unless the aircraft has DME. Pilots may refuse a clearance for an arc approach.

1. **STRAIGHT-IN APPROACHES (NO PROCEDURE TURN):** The term "*straight-in-approach*" means an instrument approach procedure conducted without a procedure turn. It is the term used by ATC in clearing aircraft to conduct such approaches.

Transport Canada is designing additional transitions on instrument approach charts to accommodate aircraft with more modern avionics equipment and to improve fuel economy. These transitions direct the pilot to a point on the intermediate approach course from which a straight-in approach may be carried out, subject to Air Traffic Control (ATC) requirements and local traffic conditions.

Where navigational aids and obstacle clearance requirements permit the construction of a transition to a straight-in approach, the plan view of the procedure depicts an "*Intermediate Fix*" on the centreline of the procedure. This fix will have a proper name (Fig. 4-26). The fix must lie on the centreline to be designated as an intermediate fix. The Intermediate Fix normally is between 5 NM and 10 NM from the Final Approach Fix. The exact distance depends on the location of navigation aids, the angle between the transition track and the final approach track, and the amount of altitude to be lost between that fix and the Final Approach Fix.

The maximum angle of intercept can require a turn of 120° to intercept the final approach track. Normally, the maximum angle is 90°, as occurs when turning onto the final approach from a DME arc. For all turns of more than 70°, a *lead radial* or bearing appears on the plan view of the procedure. This position line shows the pilot that the aircraft is 2.0 NM from the final approach track. The actual initiation of the turn-in depends on aircraft speed and wind velocity.

Many straight-in approach procedures are published in the *CAP*. Examples are straight-in ILS or NDB procedure to Runway 07 at Ottawa (Fig. 4-22) and the straight-in VOR procedure to Runway 27 from Frenn Intersection at Fredericton (Fig. 4-35). The Frenn Intersection, although not designated, is used as an Intermediate

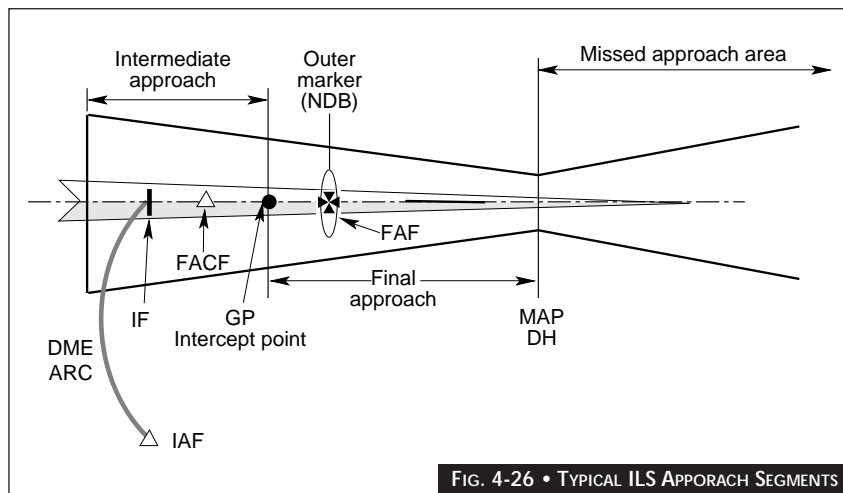

FIG. 4-26 • TYPICAL ILS APPROACH SEGMENTS



Fix. The authority for a straight-in approach is carried in the top left hand corner of the plan view as a note or by the "NoPT" symbol at the IF.

Pilots should remember that the IF is positioned approximately at the point where the inbound track would be regained after conducting a procedure turn. As in the procedure turn, after passing the fix and manoeuvring the aircraft to the proper inbound track, the pilot may descend to the FAF crossing altitude. Where more than one transition intersects the approach track at different points, only the furthest intersection is designated as the IF. The pilot may begin a straight-in approach from any transition that intersects the final approach track inside the designated IF provided that ATC is aware of the pilot's intentions and subsequent manoeuvring is within the capabilities of the aircraft.

A pilot may find the aircraft badly positioned, laterally or vertically, from the final approach track after being cleared by ATC for the straight-in approach. If so, the pilot must obtain a revised clearance before starting an unexpected procedure turn or commence a missed approach and request further clearance.

FINAL APPROACH COURSE FIXES (FACFs): With the introduction of computer based technology in modern aircraft, database suppliers and avionics manufacturers have developed standards to which instrument procedures are encoded within the aircraft computers.

In order to provide a continuous flight path for the computer, certain fixes created by the database suppliers were not part of the instrument procedure. The Final Approach Course Fix (FACF), previously known as the "centreline fix" was one of these fixes. Although the FACF was known to the aircraft computer through the database, it was not always a fix known to either the air traffic controller or the pilot.

To facilitate the use of the current and future technology that are part of modern avionics, Transport Canada has adopted the

concept of the FACF for instrument approach procedures. It is anticipated that the introduction of the FACF may help reduce the problem of false localizer course capture problems experienced by modern technology aircraft.

The FACF is defined as a fix located on the final approach course of an instrument approach procedure, approximately 8 NM from the threshold. It does not take the place of an Intermediate Fix (IF), nor the Final Approach Fix (FAF). The FACF is established prior to intercepting the glide path on a precision approach or prior to the Final Approach Fix (FAF) on a non-precision approach associated with that precision approach. The FACF has a unique ICAO five-letter pronounceable name and is portrayed on the instrument procedure chart as well as listed with the appropriate latitude/longitude co-ordinates in the *Canada Flight Supplement (CFS)*.

NOTE:

Implementation of FACFs began in 1994 and will eventually be added to Canadian instrument approaches, beginning with ILS and LOC approaches.

2. **PROCEDURE TURNS:** The pilot must make a procedure turn where no suitable fix is available to construct a straight-in approach procedure or where ATC clearance cannot be obtained for a straight-in approach. In this case the Initial Approach Fix and the Final Approach Fix are the same. The aircraft should cross the fix and fly outbound on the specified heading(s), descending as necessary to the minimum altitude at which the procedure turn should be completed.

The procedure turn is used to reduce the minimum vertical clearance from 1,000 ft in the initial segment to 500 ft in the intermediate segment. This procedure will continue at many remote locations where there is only one facility in the vicinity.

A full instrument approach clearance may include the words REPORT BEACON OUTBOUND AND INBOUND. A reason for a procedure turn where a straight-in approach is authorized is an approach clearance that includes a

restriction to cross the approach facility at an altitude far too high to allow a straight-in transition to final approach. If any doubt exists, the pilot shall request clarification.

If the approach clearance does not include these requirements, the procedure turn is optional, and ATS should be advised of intentions.

If a *minimum entry zone altitude* is not specified at the fix, the pilot may descend to procedure turn altitude immediately after crossing the fix *from any direction*, while turning to the outbound heading. If a *higher minimum altitude* is specified on the profile depicted for the approach, this altitude or higher shall be maintained until *abeam the fix outbound*. The pilot must complete the manoeuvre on the side indicated by the barb and within the specified distance onto the inbound track, then follow the inbound track to the Final Approach Fix or glide path interception, at which point the final approach commences. It is important to remain within the specified distance on the approach chart, as this ensures obstacle clearance. Typical procedure turns are described below and in Fig. 4-27.

There are *five basic variations* of the procedure turn:

- a/ The *standard* procedure turn (depicted in Fig. 4-27a): The aircraft proceeds outbound for one minute, then turns 45° away from the reciprocal of the final approach track. The pilot flies a straight segment of (normally) 45 seconds, and turns 180° in the specified direction to intercept the inbound track. This is sometimes called the *hockey stick*.
- b/ The *racetrack* pattern (Fig. 4-27 e & f). The aircraft turns over the facility or FAF and flies, for usually one to two minutes, outbound parallel to the reciprocal of the final approach track. Thereafter, it makes a turn of about 180° to intercept the final approach track.

- c/ The *80°/260° reversal* (Fig. 4-27b): The aircraft proceeds outbound for one minute, then makes a turn of 80° away from the reciprocal of the final approach track. The pilot immediately makes a turn of about 260° in the opposite direction to intercept the final approach track.
- d/ The *tear-drop* or *base turn* (Fig. 4-27 c & d): The outbound leg diverges from the reciprocal of the inbound track by 30° for one minute, or 15° for two minutes. The aircraft then turns to intercept the inbound track.
- e/ When approaching from the procedure-turn side, the pilot may fly an *S-turn*, which essentially is a modification of the 45° turn (hockey stick). Pilots must ensure that the aircraft regains the manoeuvring side of the procedure turn as soon as possible.

NOTE:

The flying times mentioned above are nominal values. Pilots should adjust timing for known wind speeds. It is essential, however, that the aircraft be kept within the distance specified for completion of the procedure turn, normally 10 NM. This distance is printed in the profile view box on approach plates (see Fig. 4-22).

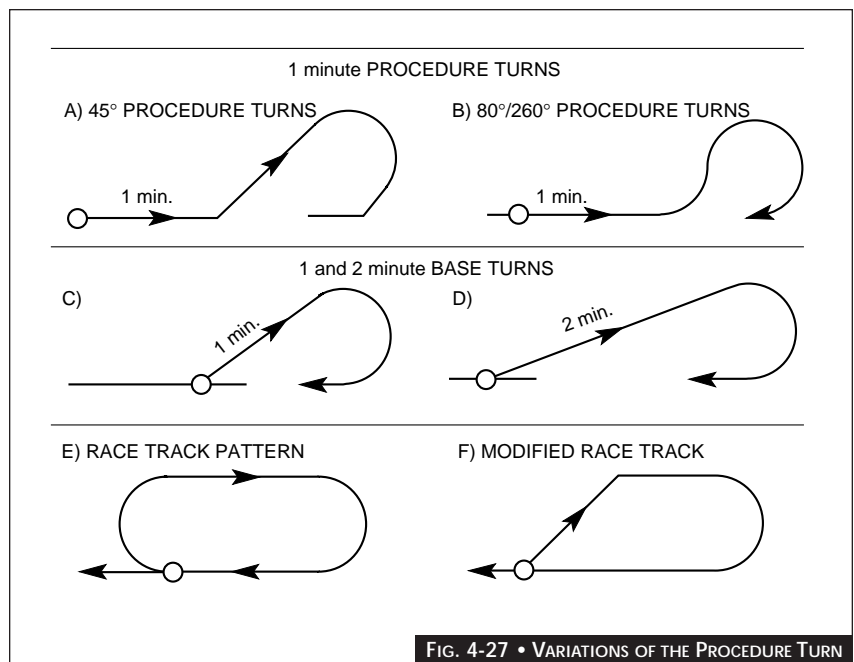

FIG. 4-27 • VARIATIONS OF THE PROCEDURE TURN

A *shuttle* is a descent or climb conducted in a holding pattern. Shuttle entry and timing are the same as a holding pattern, i.e., one minute outbound if at or below 14,000 ft ASL, or 1 1/2 minutes outbound if above 14,000 ft ASL. The shuttle is normally prescribed in a standard holding pattern so that all turns after initial entry are made to the right, except where a "non-standard" left-turn pattern will provide a significant operational advantage. A shuttle is normally prescribed only when excessive altitude must be lost during the procedure turn.

TRANSITION FROM EN ROUTE TO APPROACH PHASE WITH PROCEDURE TURN: As an en route aircraft approaches the facility upon which an instrument approach is to be flown, the pilot must consider the characteristics of the required transition from en route flight to instrument approach. Unless a straight-in approach or some other abbreviated manoeuvre is anticipated, the pilot must compare the basic tracks of the instrument approach and decide whether they align with the en route track.

In the provision of IFR separation between aircraft conducting full instrument approaches and other aircraft, ATC expects pilots to use one of the five approved intermediate approach (procedure turn) manoeuvres (Fig. 4-27) or to advise if a different manoeuvre will be flown.

There is some overlap between the five *procedure turn entry* sectors. This is not expressed in any specific number of degrees and is designed to allow the choice of either of two procedures from each overlap area.

There is only a certain sector of en route tracks that feeds smoothly and directly into the standard procedure turn manoeuvre. If the en route aircraft is flying toward the approach facility within this sector, a standard procedure turn can be flown. Other directions (or sectors) of en route track lead more directly into other approach procedures. These are described below and shown in Fig. 4-28.

It can be seen, by comparing the diagrams,

that each sector (broken lines) overlaps two others. The important objective is to fly a smooth transition from en route to final approach. Although there is no specified, hard-and-fast way to enter a procedure turn, the entry patterns described below will establish the aircraft in a turn with minimum delay and manoeuvring. A good *rule of thumb* is to turn the shortest way onto the heading that will establish the aircraft in the procedure turn.

If a pilot operating in controlled airspace anticipates being unable to conduct an approved procedure turn, he or she should inform ATC so that separation from other aircraft can be increased as necessary.

D. FINAL SEGMENT

This is the segment in which alignment and descent for landing are made. Final approach may be made to a runway for a straight-in landing or to an aerodrome for a visual circling manoeuvre to land. There are several basic variations that depend on the navigation aids available.

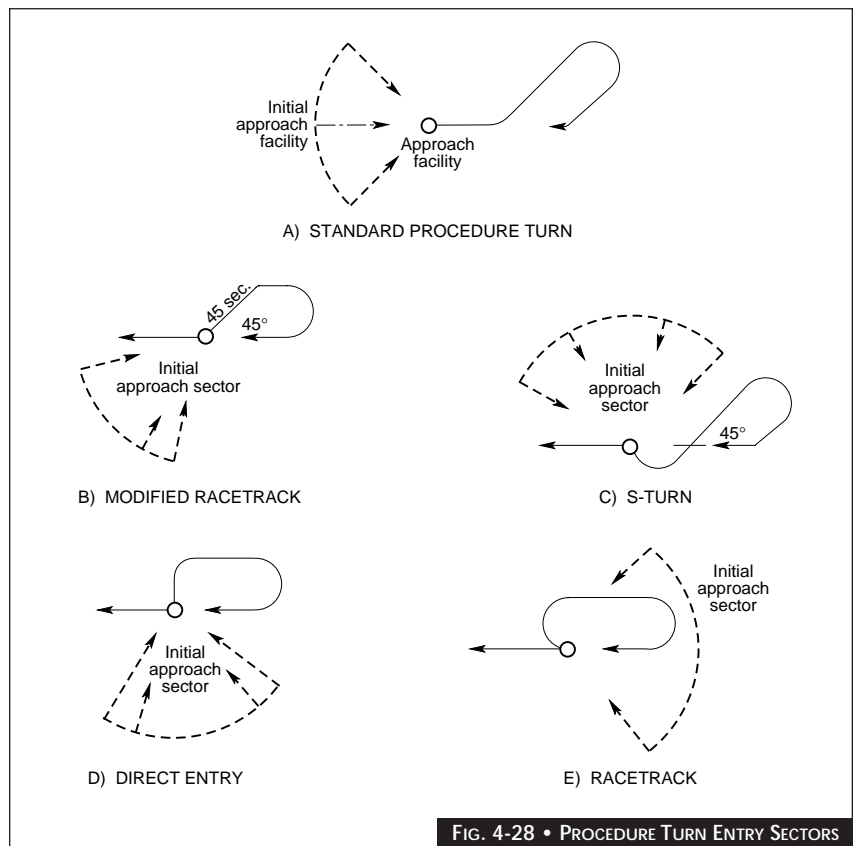

FIG. 4-28 • PROCEDURE TURN ENTRY SECTORS

1. *NON-PRECISION APPROACHES:*

WITH FINAL APPROACH FIX: The segment begins at a facility or fix called the Final Approach Fix (FAF) and ends at the missed Approach Point (MAP). The FAF is sited on the final approach track at a distance that permits selection of the final approach configuration, and descent from Final Approach Fix altitude to the runway in the case of a straight-in approach or to Minimum Descent Altitude (MDA) in the case of a circling approach. The optimum location is approximately 4 NM from the missed approach point, and the maximum distance is 10 NM.

The aircraft should cross the FAF at or above the specified altitude and then begin the descent. There are two generally accepted procedures used at this stage, depending on aircraft type and pilot preference. The pilot may begin a rate of descent that ensures that the aircraft reaches the Minimum Descent Altitude (MDA) well before the MAP. From there, the aircraft flies at the MDA until in a position to make the final descent to the runway. Alternatively, the pilot may initiate a rate of descent that permits him or her to continue, as closely as possible, the visual portion below MDA with a minimum of power changes.

WITHOUT FINAL APPROACH FIX: When a procedure is based on a single facility and no facility is situated to permit a FAF, a procedure may be designed where the facility is both the IAF and the MAP. (There is no IF in this case).

These procedures indicate a minimum altitude for a procedure turn and an MDA. In the absence of a FAF, descent to MDA is made once the aircraft is established inbound on the final approach track.

NOTE:

In procedures of this type, the final approach track normally cannot be aligned on the runway centreline. Whether straight-in limits are published or not depends on the angular difference between the track and the runway.

DESCENT PROFILES FOR NON-PRECISION APPROACHES: Coincident with the introduction of the IF concept is the use of a stabilized descent profile for the non-precision approach. For example, in the ILS or NDB 07 approach at Ottawa (Fig. 4-22), an aircraft on a 3° glide path crosses Oscar at 1,680 ft while a pilot using the NDB may cross Oscar at 1,500 ft. This 1,500 ft. altitude (the dotted line on Fig. 4-22) is the minimum altitude allowed before crossing Oscar inbound, but there is no requirement that the aircraft must cross at 1,500 ft.

Some pilots prefer a *stabilized descent*, as shown by the solid line in Fig. 4-22. In this case, the pilot considers the procedure turn altitude, runway elevation, distance from FAF to threshold, and groundspeed. *This procedure should only be used when the weather is above minima as no level-off at MDA is provided for in the calculations.* Assuming the pilot prefers a stabilized descent, the pilot need only divide the height to be lost to the threshold by the minutes to the threshold and then has the descent rate in feet per minute as follows:

Time at 120 kts	2.0 min
Height Loss (1500' - 373')	1127 ft.
Vertical Speed	1127 / 2 = 564 fpm.

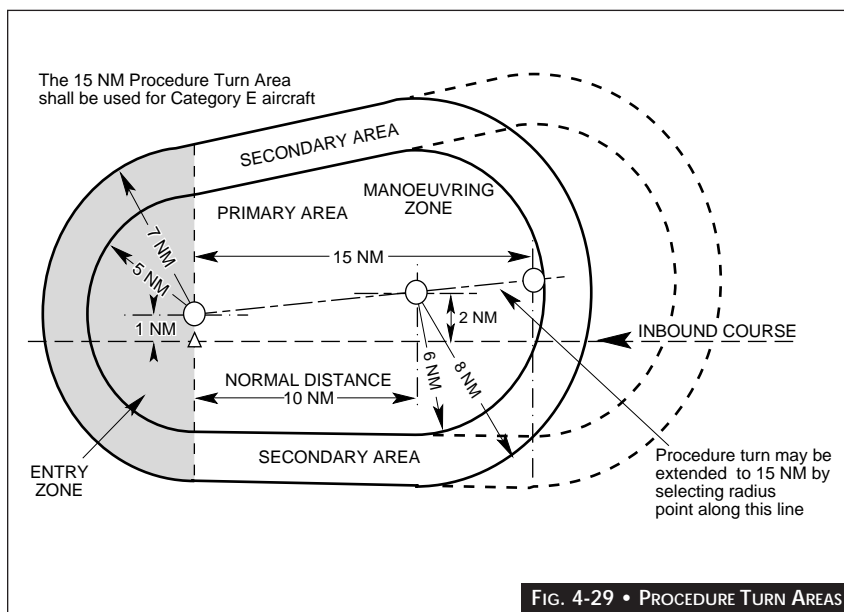

FIG. 4-29 • PROCEDURE TURN AREAS



CAUTION:

This section provides a guideline on what rate of descent to initially establish for a stabilized descent in good weather.

Similarly if the pilot desires a 3.0° descent gradient, the answer at Ottawa is easy - cross Oscar at 1,680 ft. Make sure that the aircraft descends to the MDA in time to continue visually without excessive descent for landing — usually by being at MDA by the *visibility minima* prior to the MAP.

Most FAFs in Canada are about 4 NM from touchdown. If the pilot adds 1,000 ft to the threshold elevation for FAF crossing altitude, the result is a comfortable descent of 250 ft/NM or 2.36° descent angle.

$$250 / 6.076.1 \times = .041 = 2.36^\circ$$

Adding 1,200 ft to the threshold elevation results in a 300 ft/NM descent or just about 3°.

The *preferred method* to fly NPAs is to subtract the time it would take to fly the distance associated with the visibility minima (e.g. 1NM) from the time to the MAP. If the aircraft is established at the MDA this distance prior to the MAP, the pilot should be able to make a safe landing without exaggerated and potentially unsafe power and attitude changes.

The base of terminal airspace is 1200 ft. AAE at major airports. The FAF crossing height may be set to ensure IFR aircraft do not descend below that base prior to entering the control zone.

Further information on the final approach segment is available in Article 4.6.7 - ILS approaches.

2. **TURN OVER THE FAF:** At some locations a significant operational advantage can be gained by prescribing a turn over the FAF on final approach. This permits the intermediate approach and the initial part of the final approach to be aligned away from areas of higher terrain or obstacles. In addition to following the alignment and descent gradient requirements, the pilot must re-establish the aircraft on the final

approach track at a sufficient distance before the aerodrome to permit an orderly approach and landing. Therefore, the procedures limit turns over the FAF to 30 degrees.

3. **PRECISION APPROACHES:** There are four types of precision approaches - ILS, MLS, GPS and PAR; although GPS precision approaches are not yet approved. The final approach segment begins when the aircraft is established on the final approach course and intercepts the glide path. This point is not fixed because operationally, glide path intercept points vary causing the point to move forward or backward from the nominal position.

Generally, glide path interception occurs at levels from 1,200 ft to 3,000 ft above touchdown zone elevation (TDZ). On a 3° glide path, for example, interception occurs from 4 NM to 10 NM before touchdown.

E. MISSED APPROACH SEGMENT

The missed approach is perhaps the most critical phase of the instrument approach procedure. The pilot must change the aircraft configuration and attitude, elect a subsequent course of action and obtain further clearance. For these reasons, the missed approach is kept as simple as possible. The pilot should understand clearly the missed approach point (MAP) and the missed approach procedure before beginning the approach.

The MAP can be one of the following:

- a/ decision height; or
- b/ a navigational facility; or
- c/ an intersection fix (DME, bearing, radial); or
- d/ a distance from the FAF, normally expressed as time in minutes and seconds at various ground speeds.

Upon reaching the MAP the pilot is committed to a missed approach if the *required visual reference is not established* or if a *landing cannot safely be made* by manoeuvring visually. A missed approach is established for each instrument approach procedure. It specifies a point where the missed approach procedure begins and a point where it ends. When the

required visual references are not obtained, pilots should initiate the missed approach immediately upon reaching the DH in precision approach procedures, or at a specified point in non-precision approach procedures not lower than the MDA.

NOTE:

Where the missed approach is initiated only by timing, the timing is based on the distance between the FAF and the airport.

Only one missed approach procedure is published. Alternative missed approach procedures may be issued by ATC.

The pilot must be especially careful in establishing the climb and the changes in configuration. Therefore, turns are generally not specified in the initial phase of the missed approach segment.

The missed approach may eventually require a turn and the pilot should begin to establish the specified track or heading from this point on. The missed approach segment ends at the point where a new approach, a holding, or a return to en route flight commences. Turns may commence at the MAP, at a fix, or most commonly at an altitude. When a turn is specified at the MAP, the pilot should begin the turn as soon as possible after a positive rate of climb is obtained.

NOTE:

Where a missed approach procedure specifies a routing and altitudes, the pilot must follow that routing.

For example, CLIMB 020° TO CROSS "X" NDB AT OR ABOVE 1300 FT. RIGHT TURN AT "X" NDB TO 090° CLIMBING TO 2100 FT.

The pilot must proceed via X-Ray NDB regardless of where 1300 ft is reached. If no turning point is specified, the pilot may begin the turn as soon as the aircraft reaches the specified turning altitude.

Pilots should note that the missed approach obstacle clearance surfaces *originate at the Missed Approach Point*. After descent below MDA or DH the aircraft may be below these

surfaces. In the event of a rejected landing, the aircraft could be *several hundred feet below* the obstacle clearance surface.

A pilot initiating a missed approach prior to the MAP must, if in IMC conditions, initiate the climb and *continue on the final approach course to the MAP* prior to commencing the published procedure.

4.6.3

VISUAL MANOEUVRING DURING APPROACHES

A. GENERAL

Visual manoeuvring (or landing from instrument approaches) is the term used to describe the visual phase of flight, after the pilot completes the instrument approach, to bring the aircraft into position for landing on a runway. Information on Visual and Contact Approaches is contained in Article 4.5.6C.

There are *two major types* of visual manoeuvres associated with instrument approaches:

- 1/ transition to visual flight from a straight-in approach; and
- 2/ circling.

B. TRANSITION TO VISUAL FLIGHT

1. *GENERAL:* The latest point at which a shift from instrument references to visual references may be accomplished safely is described by the MAP. For a precision approach, minima are stated in terms of decision height (DH). This is the height of which a missed approach must be initiated if the required visual reference to continue the approach to landing has not been established. *Published landing visibilities* associated with all instrument approaches are advisory only. Their values are indicative of visibilities which, if prevailing at the time of the approach, should result in the required visual reference being established. For this reason pilots should also consider forecast visibility when flight planning, and reported visibility when approach planning.

The transition from instrument to visual flight varies with each approach. The required visual references used to recognize the position of the aircraft in relation to the



runway have been described in Article 3.1.9. It is essential that these references be used properly and with discretion during the final stages of a low-visibility instrument approach. It must be remembered that in minimum visibility conditions the *visual cues* used for runway alignment and aircraft flare are extremely limited when compared to the references normally used on a visual approach.

When planning, the pilot should be familiar with the *types of lighting* installed on the landing runway, and note the distance to the airfield from available NAVAIDs. There is no substitute for proper and thorough planning as this will help in the transition from instrument to visual conditions.

Obscured conditions present a number of problems not encountered during an approach that has a definite cloud base ceiling. At the point where the aircraft breaks out below the ceiling, the visual cues used to control the aircraft are usually clear and distinct, and there is instantaneous recognition of the position of the aircraft in relation to the runway. With obscured ceilings or partially obscured conditions, the reverse is usually true; visual cues are indistinct and easily lost, and it is difficult to discern aircraft position laterally and vertically in relation to the runway.

When flying a straight-in approach in VMC, the pilot has almost unlimited peripheral visual cues available for depth perception, vertical positioning, and motion sensing. Even so, varying length and width of unfamiliar runways can lead to erroneous perception of aircraft height above the runway surface. A relatively wide runway may give the illusion that the aircraft is below a normal glide path; conversely, a relatively narrow runway may give the illusion of being high. With an awareness of these illusions under unlimited visibility conditions, it becomes easy to appreciate a pilot's problems in a landing situation in which the approach lights and runway lights are the only visual cues available.

Approach lights do not provide adequate vertical guidance to the pilot during low visibility approaches. In poor visibility,

especially when the runway surface is not visible, or in good visibility at night, there simply are not enough visual cues available to adequately determine vertical position or vertical motion. Studies have shown that the sudden appearance of runway lights when the aircraft is at or near minima in conditions of limited visibility often gives the pilot the illusion of being high. They have also shown that when the approach lights become visible, pilots tend to abandon the established glide path, ignore the flight instruments and instead rely on visual cues. Erroneous visual cues that convince the pilot that the aircraft is above the normal glide path, generally result in a pushover reaction, an increase in the rate of descent, and a short or hard landing.

To avoid excessive rates of descent during the visual portion of the approach, it is important that a *stabilized, on-speed instrument approach* be flown so that the transition to visual flight only requires small lateral and/or vertical corrections. Knowing that visual cues can be erroneous, the pilot must continue to *cross-check instruments* (or have another crew member cross-check them) even after runway and/or approach lights have come into view. Most pilots find it extremely difficult to cross-check their flight instruments once the transition to the visual segment has been made, as their natural tendency is to believe the accuracy of what they are seeing; or they continue to look outside in an effort to gain more visual cues. A *scan for outside references* should be incorporated into the cross-check as minima are approached, even though restrictions to visibility may preclude the pilot from seeing any visual cues.

2. **RESTRICTIONS TO VISIBILITY:** There are many phenomena, such as rain, smoke, snow, and haze, which may restrict visibility. When surface visibility restrictions do exist and the sky or clouds are totally hidden from the observer, the sky is considered totally obscured and the ceiling is the vertical visibility from the ground. If you are executing an approach in an obscured condition, you may not see the approach lights or runway as you pass the level of the obscured ceiling. You should be able to see

the ground directly below; however, the transition from instrument to visual flight may occur at an altitude lower than the reported vertical visibility. Also of concern is the visual range at which you will be able to discern visual cues for runway alignment and flare. The runway visibility or runway visual range (RVR) may not be representative of the range at which the runway environment is actually visible. In fact, slant range visibility may be considerably less than the reported RVR.

Landing lights may cause a blinding effect at night. The transition from approach in a total obscuration involves the integration of visual cues within the cross-check during the latter portion of the approach. Again, familiarity with the approach lighting system is required to develop the proper perspective between these cues and the runway environment.

Approaches in rain and the ensuing transition to visual flight can be hazardous since moderate to heavy rain conditions can seriously affect the use of visual cues. *Night approaches* in these conditions can be even more critical as you may be distracted by flashing strobes or runway end identifier lights. Transition to visual flight can be hampered by the inability to adequately maintain aircraft control and interpret the instruments as a result of gusty or *turbulent conditions*. Moderate or heavy rain conditions can also render the rain removal equipment ineffective, causing obscuration of visual cues at a critical time during the transition. In these conditions, an alternate course of action may be required to prevent the development of an unsafe situation.

Blowing snow is accompanied by many of the same hazards as rain, such as turbulence, obscured visual cues, and aircraft control problems. Of special interest will be a lack of visual cues for runway identification for the visual portion of the approach. The approach and runway lights will provide some identification; however, runway markings and the contrast in relation to its surroundings may be lost in the whiteness. Therefore, depth perception may be difficult, requiring more emphasis on instruments for attitude control. It is

extremely important to *avoid large attitude changes* during approaches in snow.

3. *VISUAL CUES*: Approach lights, runway markings, lights, and contrast are the primary sources of visual cues. At some facilities, touchdown zone and centreline lights may also be available. Become familiar with the lighting and marking patterns at your destination and correlate them with the weather so you will be prepared to transition to visual flight. In *minimum visibility conditions*, the visual cues and references for flare and runway alignment are extremely limited compared to the normal references used during a visual approach. Therefore, the aircraft's projected runway contact point may not be within your visual segment until considerably below published minimums.

WARNING:

Any abrupt attitude changes to attempt to bring the projected touchdown point into your visual segment may produce high sink rates at a critical time. Those so-called duck-under manoeuvres must be avoided during the low visibility approach.

4. *PILOT REACTION TIME*: At 200-foot elevation and on a 3° glide slope, an aircraft is approximately 3,800 feet from the Runway Point of Intercept (RPI). If the aircraft's final approach speed is 130 knots (215 feet per second), *you have less than 18 seconds* to bring visual cues into the cross-check, ascertain lateral and vertical position, determine a visual flight path, and establish appropriate corrections. For a Cat II approach at DH, there are *less than 9 seconds until touchdown*. More than likely, 3 to 4 seconds will be spent integrating visual cues before making a necessary control input. By this time, the aircraft will be 600 to 800 feet closer to the RPI, and 40 to 60 feet lower. Therefore, it is absolutely essential to be prepared to use visual cues properly and with discretion during the final stages of a low visibility approach. Prior to total reliance on visual information, confirm that the instrument indications support the visual perspective.

C. CIRCLING

A circling approach is an *instrument manoeuvre done visually*. Because each circling manoeuvre is different owing to variables like runway layout, final approach track, wind velocity and weather conditions, there can be no single procedure for conducting a circling approach (Fig. 4-31). The basic requirements are to *keep the airport in sight* after initial visual contact and *remain at the appropriate circling MDA until a landing is assured*. The pilot must select the procedure to remain within the protected area and to accomplish a safe landing.

The *Visual Manoeuvring Area* for a circling approach is determined by drawing arcs centred on each runway threshold and joining these arcs with tangent lines (Fig. 4-30). Pilots should be aware that the 300 ft obstacle clearance is provided only within the Visual Manoeuvring Area. *Flight outside this area is not obstacle protected*. The radius of the arcs relating to the aircraft category is shown at the right.

Choose a pattern that best suits the situation. Manoeuvre the aircraft to a safe position which allows you to keep as much of the airport environment in sight as possible. Consider making your turn to final into the wind if this manoeuvring allows you to also keep the airport environment in sight. You may make either left or right turns to final unless you are:

- a/ directed by the controlling agency to do otherwise; or
- b/ required to do otherwise by restrictions on the approach chart such as "...all circling north of runway 09-27".

If there is any doubt whether the aircraft can be safely manoeuvred to touchdown, execute the missed approach.

CAUTION:

Be aware of the common tendency to manoeuvre too close to the runway at altitudes lower than the normal VFR pattern altitude. This tendency is caused by using the same visual cues that are used for normal VFR pattern altitudes. Select a pattern that displaces the aircraft far enough from the runway to allow you to turn to final without overbanking or overshooting final, while staying within the protected airspace.

NOTES:

1. *CIRCLING MINIMA (MDA and visibility) are specified for each category of aircraft. If it is necessary to manoeuvre at a speed greater than the upper limit of the speed range for the category, the pilot must use the minima for a higher category.*
2. *Although the "STRAIGHT-IN" MINIMA may not be published on an instrument approach chart, the aircraft may land straight-*

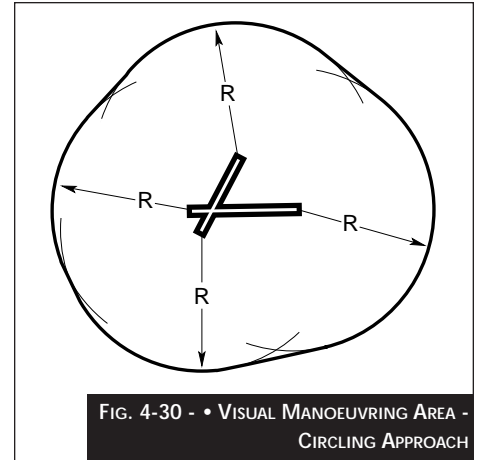

AIRCRAFT CATEGORY	SPEED	ARC RADIUS (R)
CATEGORY A	UP TO 90 KTS	1.3 NM
CATEGORY B	91 TO 120 KTS	1.5 NM
CATEGORY C	121 TO 140 KTS	1.7 NM
CATEGORY D	141 TO 165 KTS	2.3 NM

in if the runway is in sight in sufficient time to make a normal descent to the runway. At controlled airports this should be confirmed with the tower controller. At uncontrolled airports the pilot must be alert to the possibility of aircraft or vehicles on the runway, and broadcast the fact that a straight-in landing is going to be accomplished.

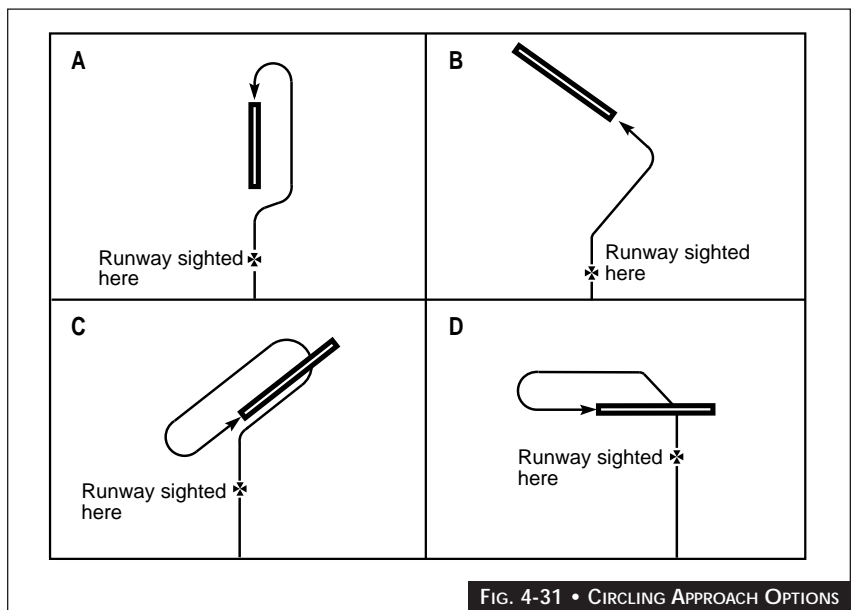

3. *Circling restrictions (Fig. 4-32) are published at some locations to prevent circling in certain sectors or directions where higher terrain or prominent obstacles exist. This practice allows the publication of lower minima than would otherwise be possible. In such cases, the circling MDA does not provide obstacle clearance within the restricted sector. For another example, see Fig. 4-33.*

shortest way to intercept the outbound track using the same drift correction. Complete the first 5-T check.

A handy reference for flying NDB approaches is as follows:

- 1/ *inbound to the beacon* - "desired to the head (of the needle) plus correction";
- 2/ *outbound from the beacon* - "tail (of the needle) to desired plus correction".

D. MISSED APPROACH PROCEDURE

It may become necessary to conduct a missed approach after starting visual manoeuvres. There are no standard procedures in this situation. Unless the pilot is familiar with the terrain, it is recommended that:

- 1/ a climb be initiated;
- 2/ the aircraft be turned towards the centre of the airport; and
- 3/ the aircraft be established, as closely as possible, on the missed approach procedure track published for the instrument approach procedure just completed.

Even with the airport in sight at circling MDA, the pilot should execute the missed approach if there is any doubt that the ceiling and visibility are adequate for manoeuvring safely to the point of touchdown.

4.6.4 NDB APPROACHES

For an example of an NDB approach, see Fig. 4-33.

A. STATION PASSAGE

At all altitudes, initial station passage is considered to be that point at which the ADF bearing pointer moves through the "wing tip" position. At high altitude, the bearing pointer may take from 1 to 3 minutes to stabilize at the 180-degree position. At low altitude, because of the narrow width of the cone of confusion, oscillation of the bearing pointer may be slight. Close to the beacon there is a rapid movement of the bearing pointer. Chasing the bearing pointer should be avoided as the track errors close to the beacon are minimal. Fly the heading that has been used tracking inbound to the beacon; then, upon station passage, turn the

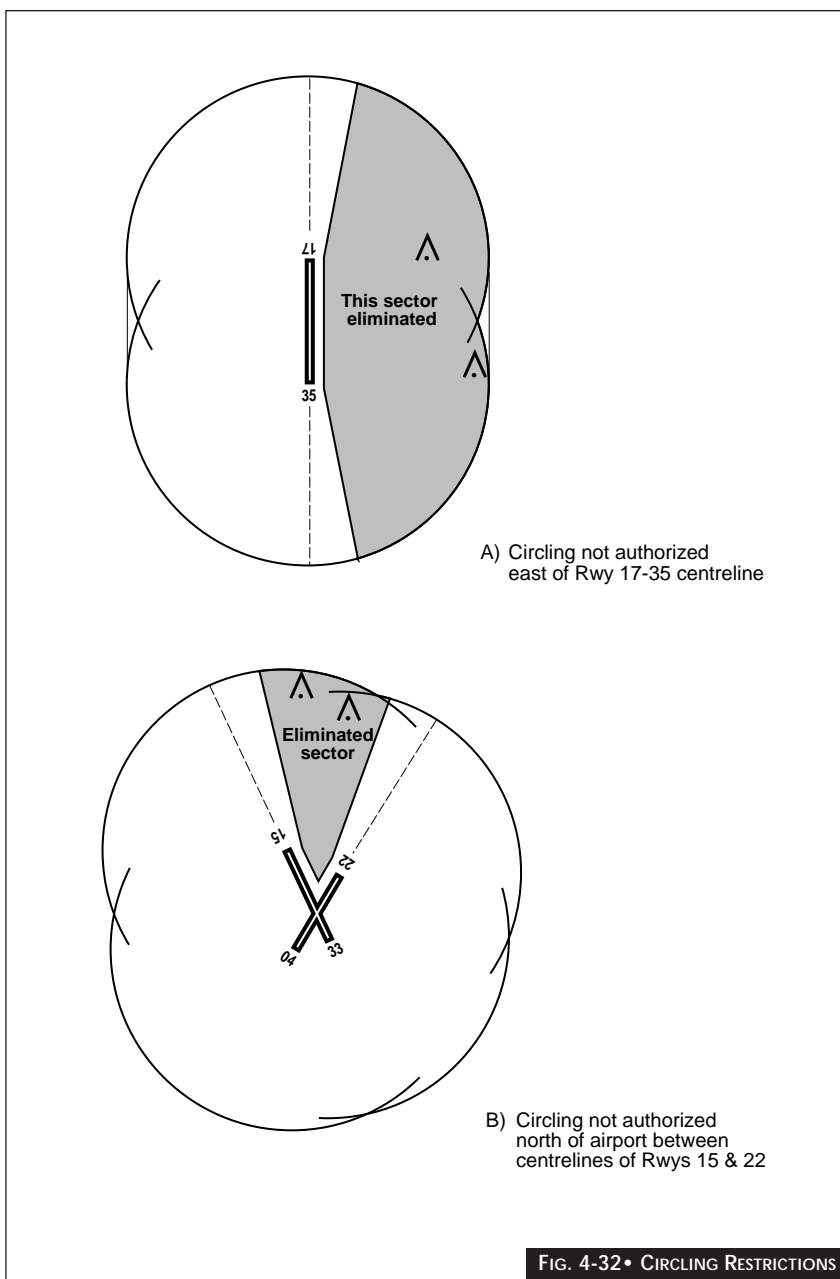

FIG. 4-32 • CIRCLING RESTRICTIONS

B. 5-T CHECK

The following "5T" check is completed immediately after station passage **outbound**.

CHECK	ACTION
T - Time	Note the time at which the aircraft started to fly outbound.
T - Turn	If required, turn onto a heading which will intercept the outbound track.
T - Track	Fly required track for selected procedure turn, compensating for drift.
T - Throttle	Reduce the throttle setting as required, and start or continue a descent to the published procedure turn altitude. Adjust the airspeed as required.
T - Talk	Pass a position report to the controlling agency if at an uncontrolled aerodrome. At controlled aerodromes, pass only those position reports requested by ATC. (WINNIPEG ARRIVAL, GOLF ALPHA LIMA MIKE, BY THE BEACON OUTBOUND).

thorough pre-approach planning. At station passage **inbound**, complete a second "5T" check as follows:

CHECK	ACTION
T - Time	Note the time at "station passage" and start timing.
T - Turn	If required, turn onto the planned inbound heading.
T - Track	Fly inbound track adjusting for drift. Use small corrections to avoid overcontrolling.

C. NDB APPROACH (BEACON OFF THE FIELD)

Normally, the pre-landing check is completed during the outbound portion of the procedure turn, but the Aircraft Operating Manual should be consulted for the particular type of aircraft being flown. The aircraft should not descend below the published procedure turn altitude during any portion of the procedure turn. Fig. 4-33, for example, authorizes 3,200 ft as the procedure turn altitude.

Once the aircraft is flying **inbound**, good tracking is essential. Eliminate drift as soon as possible because, normally, you will be able to apply the same drift correction from the station inbound to the aerodrome. Avoid large heading changes when approaching station passage. *Descent from procedure turn altitude* to final approach fix altitude can only be made when the aircraft is on course inbound to the beacon (tolerance is $\pm 5^\circ$).

The *final approach* from the beacon to the aerodrome is the most critical part of the approach: success depends to a large extent on

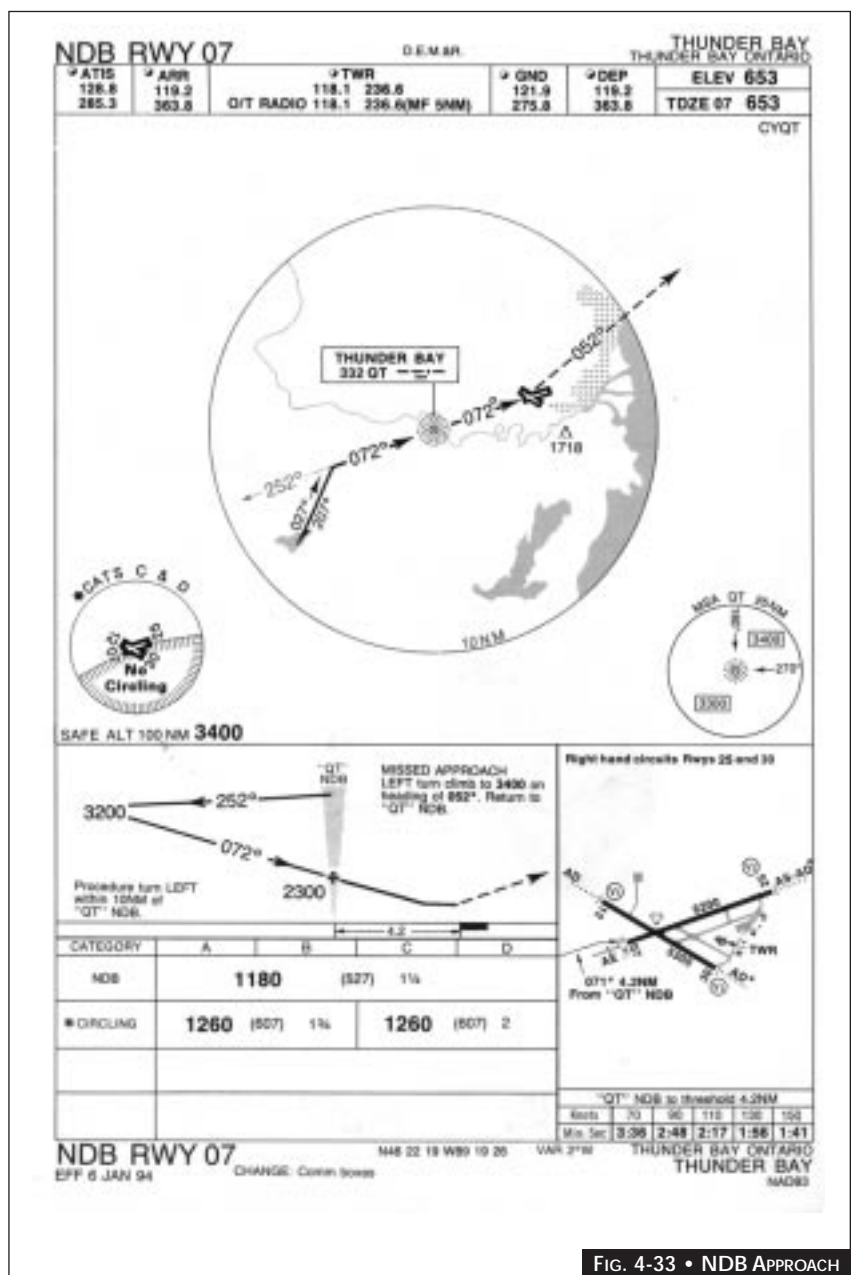

Fig. 4-33 • NDB APPROACH

CHECK	ACTION
T - Throttle	Reduce the throttle setting as required, and start a descent to the published minimum descent altitude. The aircraft should be level at MDA prior to the point that permits a normal flight path to the runway (See Article 4.6.2D). Adjust the airspeed and aircraft configuration as required.
T - Talk	Pass position to the controlling agency, (if required). (WINNIPEG TOWER, GOLF ALPHA LIMA MIKE, BY THE BEACON INBOUND).

When the ADF bearing pointer stabilizes, ascertain the amount of track error and make an appropriate correction to the track. Avoid large heading changes at this stage, because the aircraft is close to the station. Maintain the published MDA and approach airspeed and look for visual references. Refer to Article 4.6.2 D.1 for more information on the two methods of conducting descents to MDA.

If a *missed approach* is required, the pilot should follow the published missed approach procedure, inform the controlling agency of intentions, and request further clearance.

A MISSED APPROACH IS MANDATORY WHEN:

- 1/ the time to the MAP has elapsed without the required visual reference being sighted; or
- 2/ a safe landing is not possible; or
- 3/ the controlling agency instructs the pilot to go around; or
- 4/ track guidance to MAP is not available (NDB goes off the air).

D. BEACON-ON-THE-FIELD NDB APPROACH

Some NDB approaches are based on a facility that is positioned on the field (ie., within 1 NM). This gives rise to some unique problems:

- 1/ unless a final approach fix is established at some point on the final approach track (ie., DME or cross-bearing), the pilot will not

have any indication of the *distance from the runway* from the time the aircraft proceeds outbound until the runway environment is sighted or the aircraft crosses the NDB a second time when flying inbound;

- 2/ the *outbound portion must be extended* to ensure sufficient straight away on final to accomplish the required descent to MDA (not to exceed the maximum procedure turn distance published); and
- 3/ *check list items* normally carried out at beacon-crossing inbound should be completed at the completion of the procedure turn.

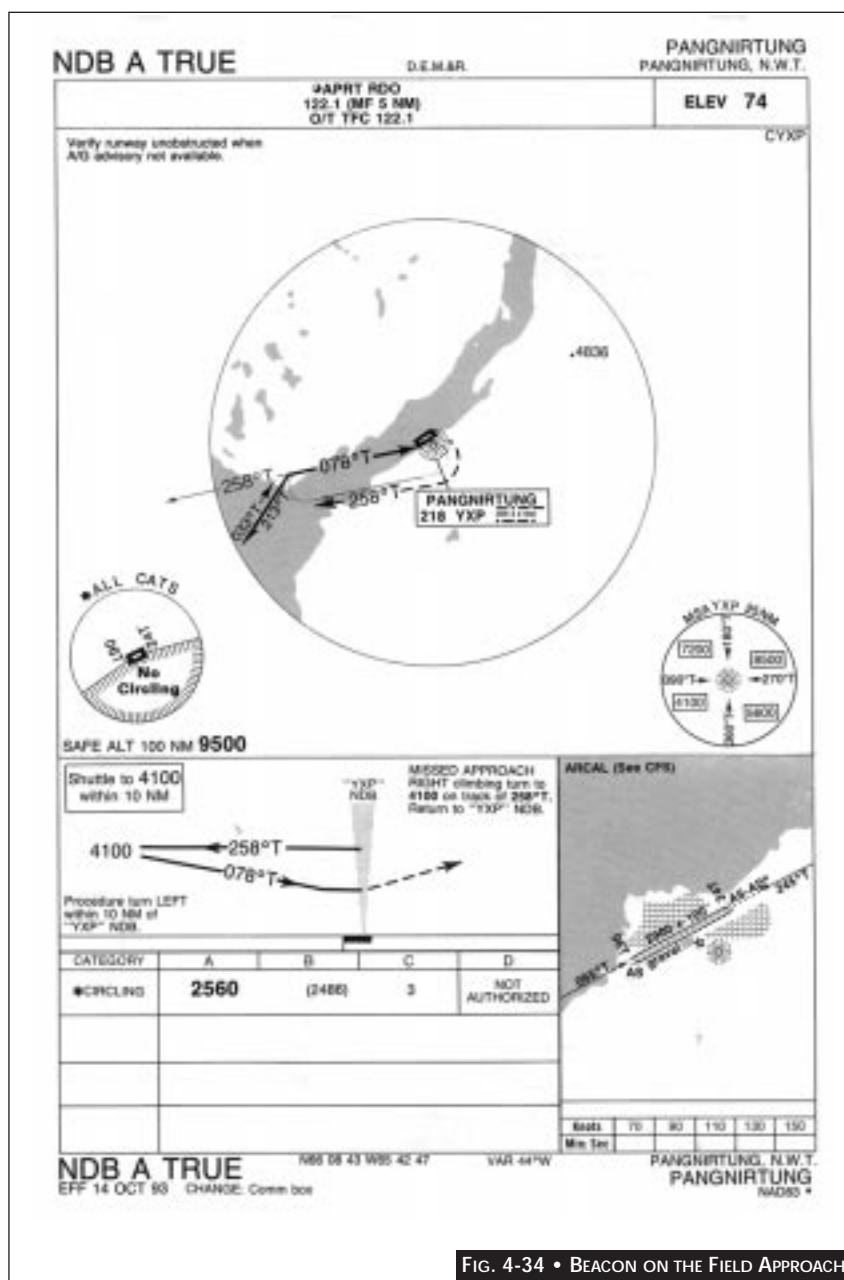

FIG. 4-34 • BEACON ON THE FIELD APPROACH

4.6.5 VOR APPROACHES

The procedures for NDB approaches (including the 5-T checks and descent considerations) apply to VOR approaches (see Fig. 4-35) with two exceptions. First, the *track bar indicator* will provide visual reference for the relative position of the aircraft to the track selected on the HSI or omni bearing selector (OBS). Second, *station passage* is indicated by the TO-FROM flags on the instrument face. One advantage of VOR approaches is that the VOR is not susceptible to bank error.

Some VOR approaches use DME or NDB fixes to establish a Final Approach Fix (Fig. 4-36). Usually such a fix is established approximately 4 NM from the threshold of the runway. This use of DME on VOR approaches allows for lower landing minima. An instrument approach chart entitled "VOR/DME" for a specific runway requires both VOR and DME equipment to fly that approach.

During the procedure turn for a VOR approach, the inbound track should be set in the OBS or track selector window. Close to the VOR, the radials converge; therefore, small heading corrections should be used to avoid overcontrolling. With the final approach inbound course set in the track window, fly toward the needle to maintain course.

4.6.6 LOC AND LOC (BC) APPROACHES

A. LOC APPROACHES

A front course ILS approach without glide slope information is called a LOC or localizer approach. The procedure is similar to a normal ILS approach until the aircraft intercepts the localizer inbound. Complete the appropriate 5T checks inbound (and outbound if required).

After the localizer has been intercepted, the aircraft may descend to the published FAF-crossing altitude if different than the procedure turn altitude. Fig. 4-22 indicates the FAF crossing altitude for the LOC or NDB approach is 1500 ft. This altitude will provide obstacle clearance on the final approach prior to passage of the FAF. When station passage at the FAF

has occurred, begin a descent at a predetermined rate in order to bring the aircraft down to the published "LOC" MDA at the appropriate distance from the MAP. (see Article 4.6.2D).

Some ILS approach charts depict glide path inoperative FAF-crossing altitudes using a dotted line. (see Fig. 4-39)

B. LOC (BC)

The localizer back course (LOC (BC)) is the track line along the extended centreline of the

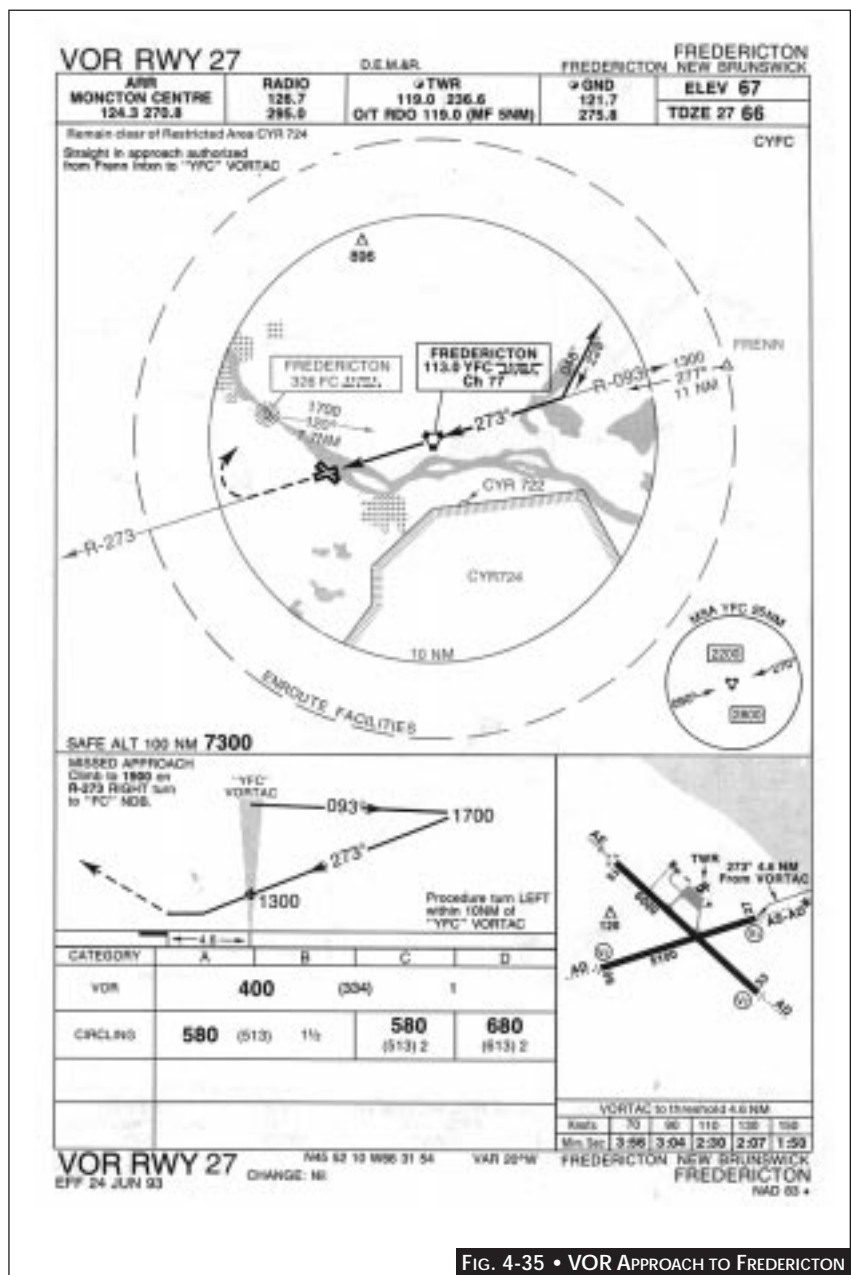

FIG. 4-35 • VOR APPROACH TO FREDERICTON

runway in the direction opposite the front course localizer. Back course approaches use the same localizer equipment as the front course ILS approach for the reciprocal runway. The back course incorporates only azimuth guidance and because of the absence of glide slope information, is a non-precision approach (see Fig. 4-37). It is important that the pilot *ignore all glide path indications* when carrying out a LOC (BC) approach.

Many aerodromes in Canada have a published back course procedure. Study the LOC (BC) approach chart thoroughly while planning the approach and note the headings and altitudes to fly. Pay attention to the distance from the FAF to the runway and the altitude to be lost within this distance. Care must be taken to ensure that the *localizer front course is selected in the track selector window*.

In general, the procedures used are similar to those of a front course ILS approach. The differences usually lie in the final approach, where difficulties may be experienced in orientation.

During a LOC (BC) approach, the track deviation bar (TB) must be *read in reverse* unless the equipment has reverse sensing capability (such as an HSI). In other words, to remain on the localizer course, the pilot must make any necessary corrections away from the needle instead of toward the needle. The same situation occurs when using the front course as the departure navigation aid. Therefore, when flying outbound on the front course or inbound on the back course, the pilot must interpret the TB in reverse (unless the aircraft equipment has reverse sensing capability).

Use caution when making corrections to regain or maintain the back course. Also, make only *small corrections as the aircraft approaches the transmitter*. This is because of the very narrow beam width close to the facility. Remember that the localizer is located approximately 1,000 ft short of the runway on the back course end.

In HSI equipped aircraft, no apparent instrument reversal exists. Therefore, the approach is flown much like a front course localizer. Some Flight Directors also compensate for perceived instrument reversal. Check aircraft manuals and operating handbooks for complete details.

Calculate the time to the missed approach point while planning the approach. Remember that the speed used is groundspeed (in knots). Since the point for missed approach is usually over the runway threshold, it is necessary to be at MDA *prior to expiry of the timing* in order to land from the approach.

Every localizer has a back course; however, because of equipment location, obstructions or other factors, there may not be a back course approach procedure published in the *Canada Air Pilot*.

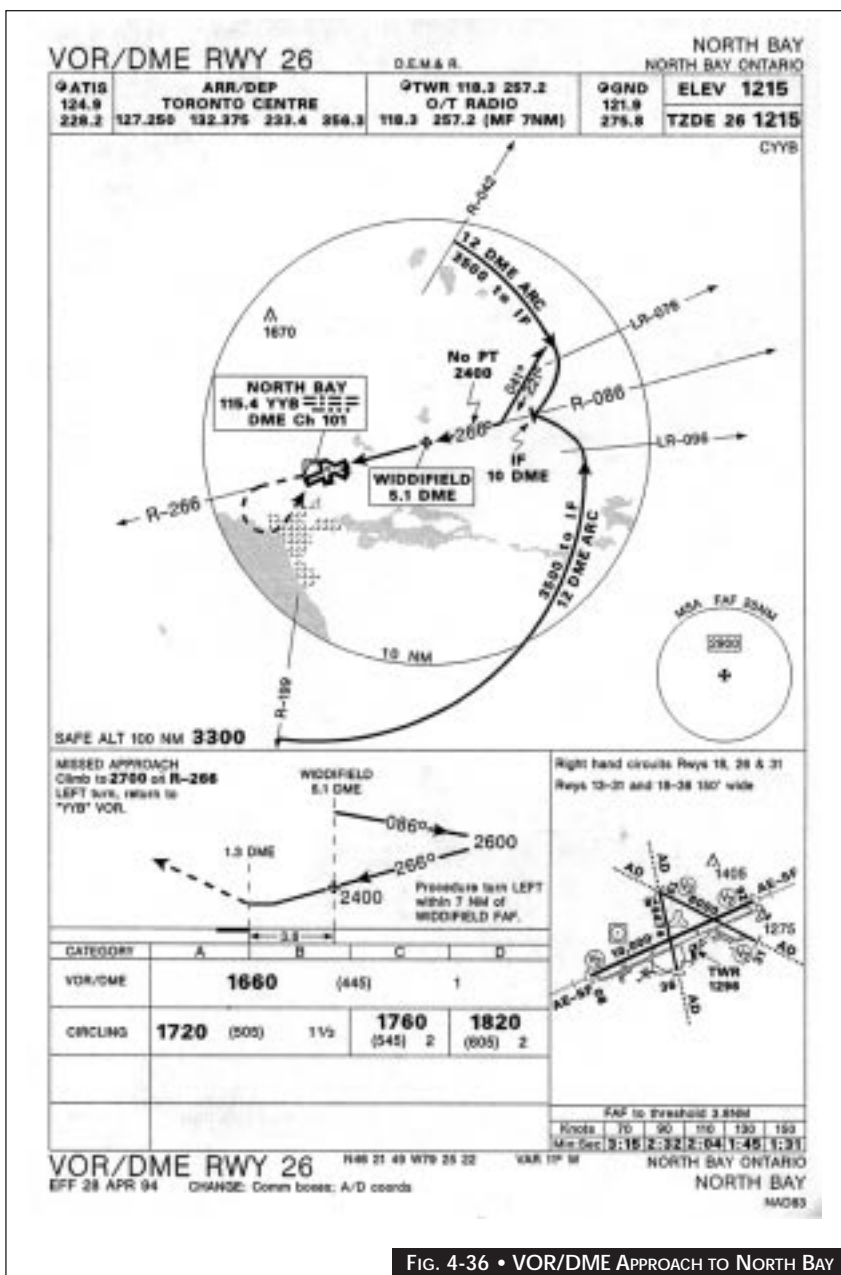

FIG. 4-36 • VOR/DME APPROACH TO NORTH BAY

4.6.7 ILS APPROACHES

ILS approaches in Canada are divided into two categories: CAT I and CAT II.

A. CATEGORY I (CAT I)

The basic ILS approach is called Category I. An instrument rating qualifies the pilot for Category I ILS approaches. The *basic minima* for Category I approaches is a decision height (DH) of no less than of 200 ft above the touchdown zone. The advisory visibility limits are normally 1/2 SM or RVR26. The actual minima may be higher than 200 ft for a number of reasons including terrain or if one or more of the system components or visual aids are either not installed or temporarily inoperative.

B. CATEGORY II (CAT II)

"CAT II" approaches require special runway, aircraft and pilot certification. Basic CAT II minima are RVR 12 and no lower than 100 ft decision height. For an example, see Fig. 4-38. CAT II decision height is based on *radar* altimeter indications, while CAT I DH is predicated on *barometric* altimeter indications.

There are four basic types of requirements for landing with Category II minima: (1) air carrier or operator approval by Transport Canada; (2) special pilot qualifications; (3) special aircraft qualifications with regard to certification and equipment; and (4) runway and facility qualifications, including the installation and certification of rather sophisticated equipment and conformance with stringent clearway (obstruction clearance) regulations. More information on CAT II ILS approaches is available in TP 1490, *Manual of All Weather Operations (Category II)*.

C. FLYING THE ILS

An example of an ILS approach chart is shown at Fig. 4-39.

Difficulties have been encountered in positioning aircraft inbound on ILS localizers. These difficulties arise during transition to a straight-in procedure while the aircraft is still outside the area of localizer reliability. This can occur outside 35° of the nominal approach course (Fig. 2-82) within 10 NM, or 10° of the

approach course past 18 NM.. Pilots operating on transitions, including arcs to the intermediate fix may encounter signal anomalies (*false localizers*) while outside the area of reliable navigation signal.

Pilots must *confirm their position* when conducting an ILS as follows:

- 1/ on an arc transition, the interception of the lead radial occurs at approximately 2 NM from the localizer intercept;
- 2/ on a bearing, radial or dead reckoning track, an ADF bearing can confirm localizer

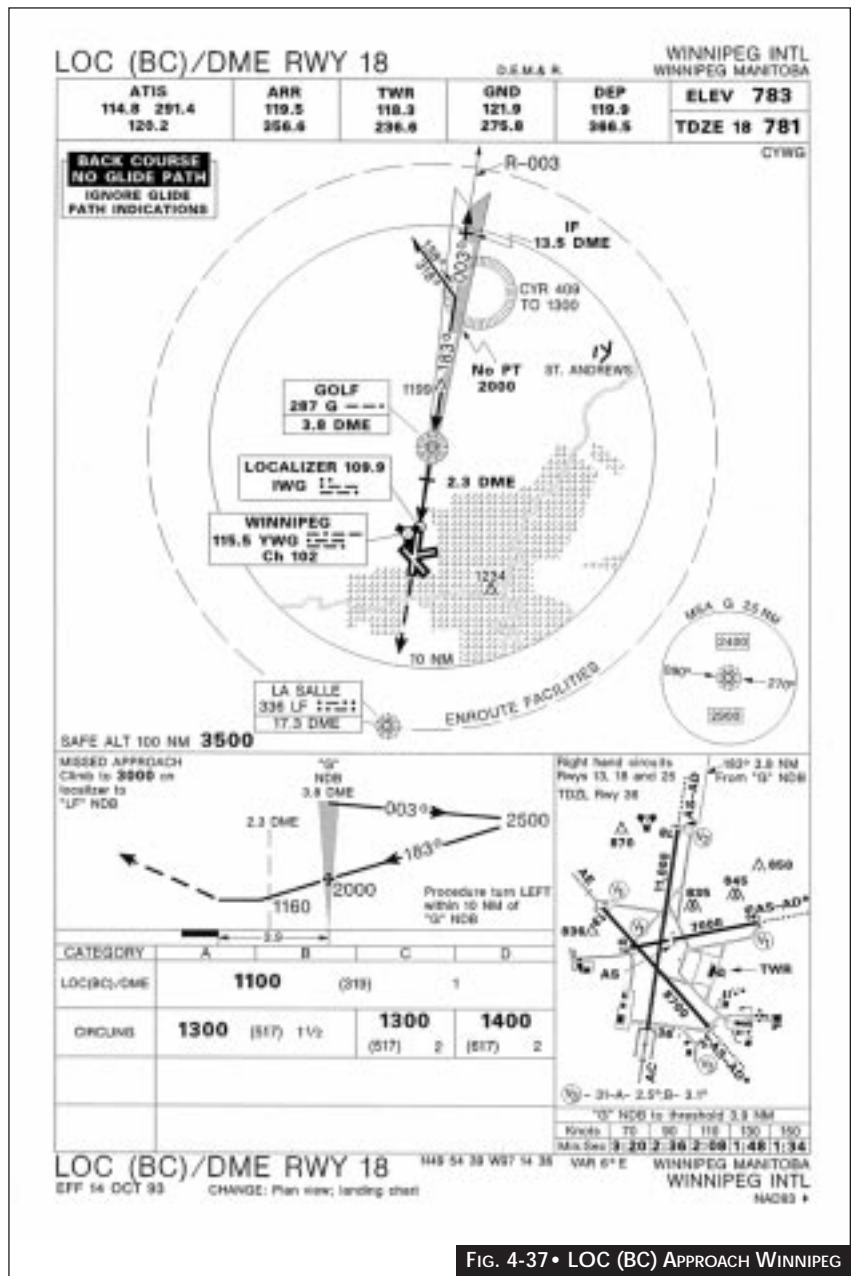

FIG. 4-37 • LOC (BC) APPROACH WINNIPEG

intercept. If cleared for ILS approach without radar vectors or a published transition to follow, the pilot shall proceed directly to the NDB or IF ensuring that, while in transit, the aircraft is not flown at an altitude lower than the appropriate minimum IFR altitude;

- 3/ on radar vectors, a clearance for the ILS approach is not normally issued until the aircraft is approaching the final approach course.

In all cases, the final confirmation will be that the aircraft track is identical to the localizer bearing with the track bar centred.

Thereafter, the aircraft should adhere strictly to the on-course, on-glide path indications. A half-course azimuth deflection or a half-course fly-up deflection places the aircraft near the edge or bottom of the *protected airspace*, where loss of obstacle clearance can occur.

For safety reasons, intermediate approach tracks or radar vectors place the aircraft on the localizer at an altitude below the nominal glide path prior to glide path interception. If the aircraft is inbound on the localizer *above the glide path* the pilot must use extreme caution, because he or she must follow a non-standard procedure and might require an excessive rate of descent to regain the glide path.

During the latter stages of the procedure turn, fly a heading to intercept the localizer inbound (it is recommended to use a maximum 45-degree interception angle). Interpretation of the rate of movement of the track bar allows start of the turn inbound with the correct amount of lead. The aircraft must not be allowed to descend below the published procedure turn altitude.

Initially, the Glide Slope Indicator (GSI) should be at the top of the instrument, which means the glide path is above. Unlike the track bar, the GSI is always directional: flying towards the GSI will bring the aircraft back to the glide path. The GSI will start moving down towards the centre of the instrument, and normally interception of the glide path will occur before the aircraft arrives over the FAF. The *published FAF altitude* on the approach chart is only an altimeter and glide path check - it is *not a safety height*. It should be used to confirm correct

altimeter reading and that the aircraft is not flying a false glidepath. Variations due to temperature are to be expected with ± 100 ft quite normal. Include the GSI in the instrument cross-check in preparation for the interception, and be ready to begin a descent when the indicator approaches the centre. The amount of lead is governed by the rate of movement of the GSI so that, by the time the indicator is in the centre of the instrument, a definite rate of descent should have been established. Adjust power and configuration, when necessary, to maintain the desired airspeed and rate of descent.

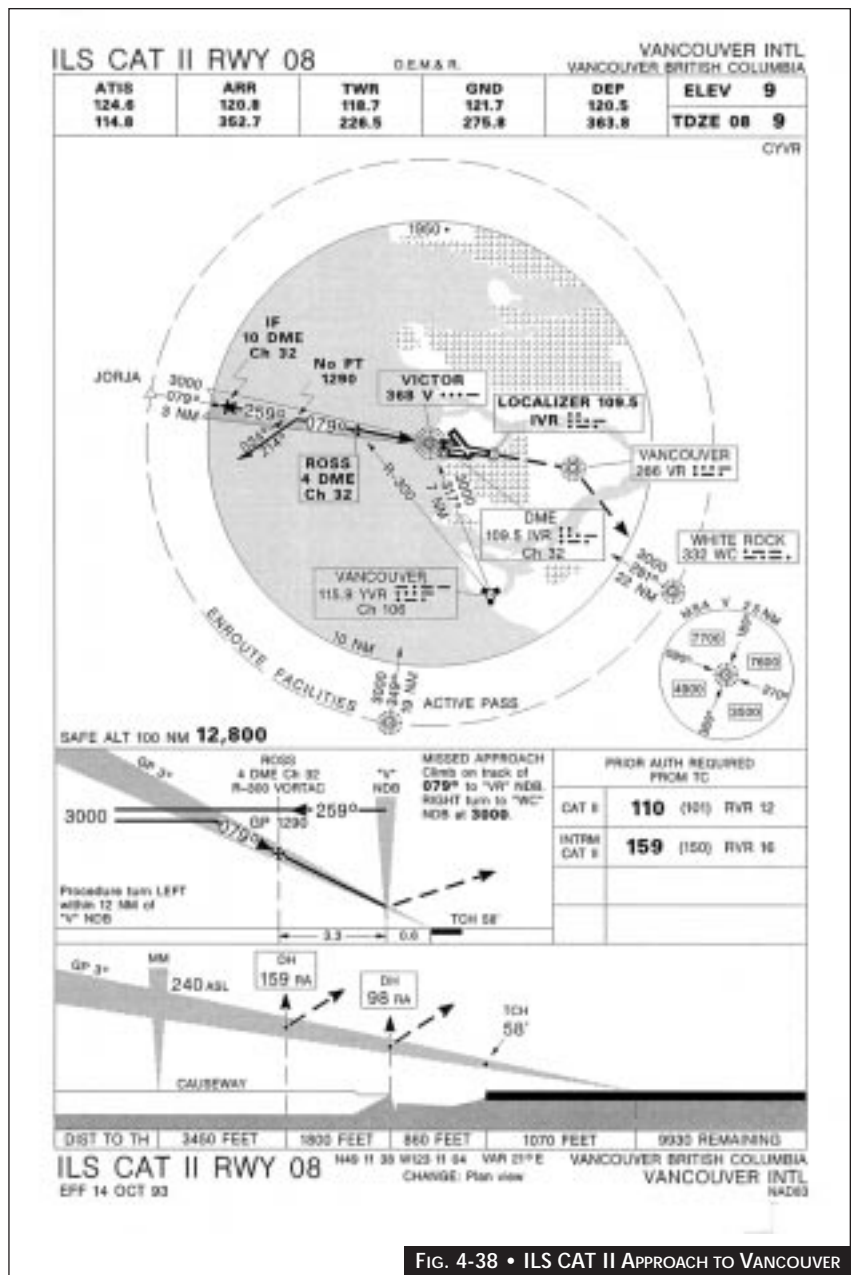

FIG. 4-38 • ILS CAT II APPROACH TO VANCOUVER

A constant rate of descent and heading should be maintained until one or both of the indicators move away from the centre. When a deviation of the GSI is detected, adjust the rate of descent by flying towards the indicator. The narrow depth of the glide path causes rapid movements of the indicator, so usually only small adjustments to the rate of descent are necessary to return the indicator to the centre. Should the aircraft drift off the localizer, causing the track bar to move away from the centre, make a correction towards the track bar using the aircraft compass to regain the localizer, and then select a new heading which includes an allowance for drift. The track bar is not a flight instrument; therefore all corrections to track must be made on the compass.

The *final approach segment* starts at a fix or facility that permits verification of the glide path/altimeter relationship. The outer marker (OM), DME or an NDB are normally used for this purpose.

If there is an NDB located at the outer marker, there will be a normal indication of station passage. Like other types of approaches, a "5-T" check should be completed crossing the IAF outbound and the FAF inbound.

When the aircraft is established on the localizer course and the glide path, and near the approach end of the runway, corrections should be confined to small changes of heading and rates of descent. This is necessary because of the rapidly decreasing width of both beams, which becomes evident by the increasing sensitivity of both the track bar and GSI.

If at any time on final approach prior to DH *full-scale deflection* of the localizer occurs, initiate a missed approach. When *full-scale down* deflection occurs on the GSI, descent to a non-precision MDA may be continued without using excessive rates of descent. If *full-scale up* deflection occurs on the GSI, the aircraft should overshoot since obstacle clearance is not assured.

If glide path guidance is lost (i.e. flagged off) during the approach, the procedure becomes a non-precision approach. The pilot may descend to the LOC MDA at the appropriate time, providing that an MDA is published for the glide path inoperative case, as in Fig. 4-39.

As with all approaches, descent below the MDA

or DH *MUST* be made *only when the required visual references are available*.

If the required visual reference to land cannot be attained at the published minimum altitude (DH), start a missed approach procedure. While some descent below DH may occur during the transition from descent to climb, it is imperative that this be minimized by prompt and positive aircraft control. Once the decision to overshoot is made and the aircraft is climbing away according to the published missed approach procedure, inform the controlling agency of your action and intentions. Request further clearance.

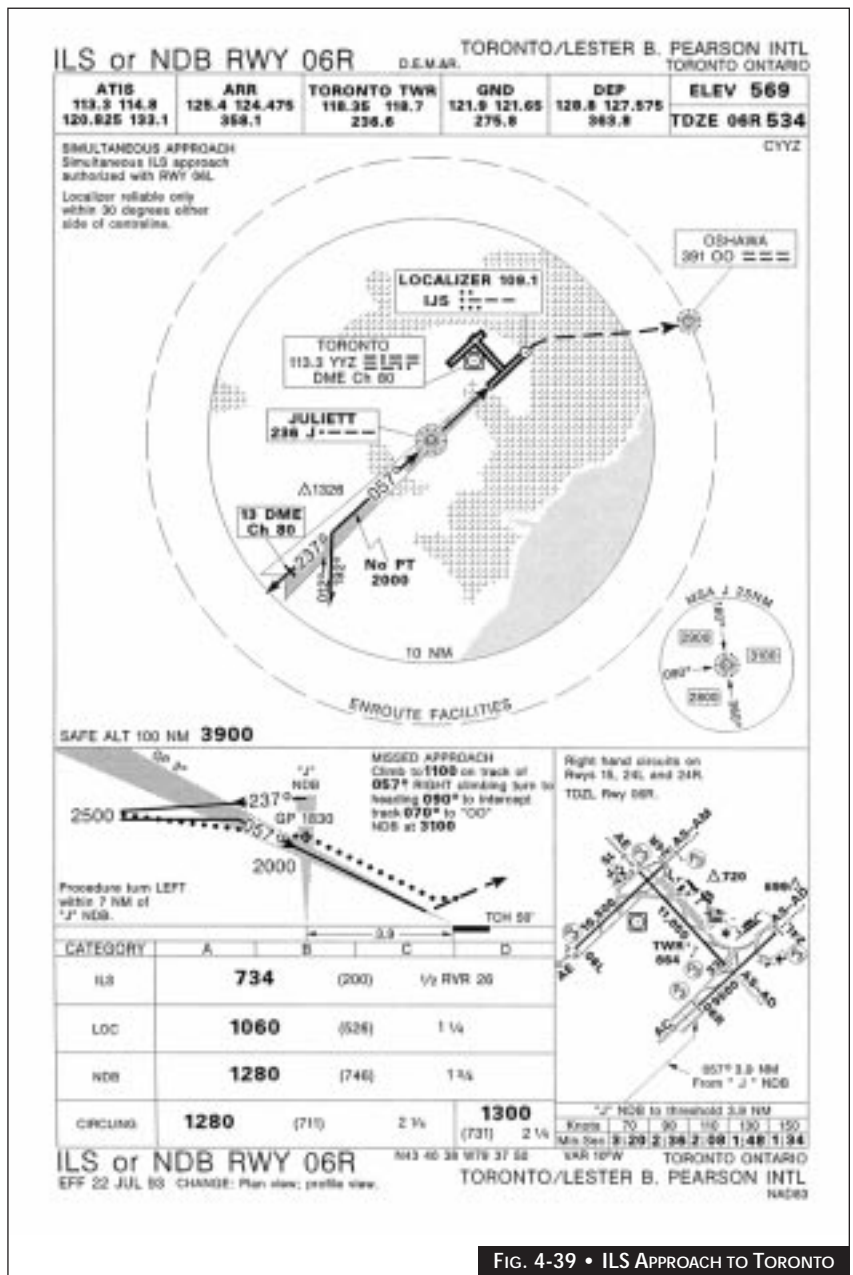

FIG. 4-39 • ILS APPROACH TO TORONTO

4.6.8
RADAR APPROACHES

A. GENERAL

Air Traffic Control applies radar separation to arriving aircraft to establish and maintain the most desirable arrival sequence and avoid unnecessary "stacking" or delays. In the approach phase, radar vectoring establishes the aircraft on an approach aid. Aircraft are vectored to intercept the final approach course approximately two miles from the point where final descent begins. In a precision radar approach, ATC vectors the aircraft by surveillance radar to a predetermined position, where it transfers control to the precision radar controller for the "talk down".

EXAMPLES:

SDC, ARRIVAL, 3 MILES FROM THE OUTER MARKER, TURN RIGHT HEADING 180 TO INTERCEPT FINAL APPROACH COURSE. CLEARED TO THE TORONTO AIRPORT FOR STRAIGHT-IN ILS RUNWAY 15 APPROACH.

or for radar approach

SDC, ARRIVAL, TURN LEFT HEADING 230 FOR FINAL APPROACH. 8 MILES FROM THE AIRPORT. CLEARED TO THE GREENWOOD AIRPORT FOR A PRECISION RADAR APPROACH, RUNWAY 26.

B. PRECISION APPROACH RADAR (PAR)

Precision Approach Radar (PAR) is provided at some military airports. The PAR approach provides azimuth, range and glide-path information. The normal weather limits for PAR are a 200 foot ceiling and 1/2 mile visibility. Minima for PAR approaches, and the locations where they are available, are published in the GEN section of CAP.

The approach may be conducted *without a serviceable compass* by following the radar controller's directions. *Total radio failure* may also be overcome by tuning in an NDB with voice capability and the PAR controller will broadcast instructions to the aircraft using the NDB frequency. Failure to acknowledge

instructions prior to final approach will initiate a receiver-only PAR. The *Canada Flight Supplement* also details those military airfields where PAR is available and those which have the capability to broadcast on an NDB (by listing a "T" after the frequency).

From the pilot's point of view, the radar approach is divided into the traffic pattern and the final approach. The *traffic pattern* includes manoeuvring up to a point which is 7 to 8 miles from touch-down on the final approach track. All turns during the traffic pattern are made at a standard rate (RATE 1). The *final approach portion* begins immediately after the traffic pattern and ends when the landing is completed or when the aircraft starts a missed approach procedure. All turns during the final approach should not exceed a rate 1/2 turn.

While the aircraft is flying the traffic pattern portion of the radar approach, the controller, after establishing radar identification, will ask the pilot to read back the altimeter and altitude. Alternate instructions will then be issued if required, followed by landing information. The glide path angle and decision height will be given on a downwind leg. On the base leg, the final controller will confirm altitude and altimeter. Lost communication and missed approach instructions will then be given. Fig. 4-41 refers.

Before reaching the glide path, speed should be reduced to the final approach speed recommended for the particular type of aircraft. When the radar controller sees the aircraft intercepting the glide path, the pilot will be instructed to commence descent for the appropriate glidepath angle. Glide path information is passed regularly to provide an accurate indication of the aircraft's position in relation to the glide path.

Accurate heading control is most important during the final approach to assist the controller in aligning the aircraft on the final approach track. Correction to new headings should be made immediately. The radar controller always

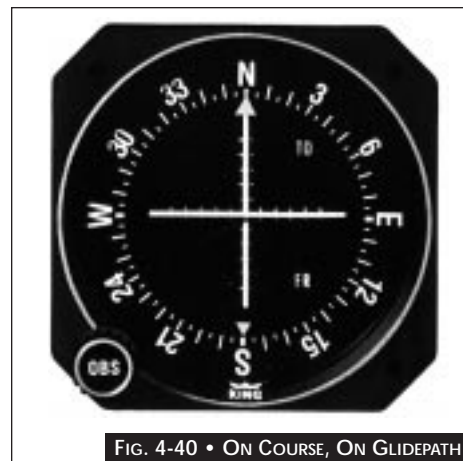

FIG. 4-40 • ON COURSE, ON GLIDEPATH

bases new instructions on the assumption that previous instructions have been carried out. PAR controllers can also be utilized to provide radar monitor during ILS approaches.

C. AERODROME SURVEILLANCE RADAR (ASR)

The Aerodrome Surveillance Radar (ASR) approach uses the surveillance capability of the radar system to provide azimuth and range information to the pilot. The controller has no indication of the aircraft's altitude or position relative to the ideal glide path. The weather limits for ASR approaches are normally a 400 foot ceiling and 1 mile visibility.

The *traffic pattern* stage of the surveillance approach is identical to that of the precision approach. During the *final approach*, up to the point of glide path interception, the same instructions as for a precision approach are received. Establish a rate of descent when instructed to do so, but, since no glidepath information is available during a surveillance approach, instructions cannot be issued for correcting the rate of descent. The controller, however, can give the optimum altitude for each mile of the approach. If this information is desired, it should be requested by the pilot during the traffic pattern. After level off at MDA, continue until runway environment is sighted or until advised by the radar controller that the MAP has been reached.

At Canadian civil airports, where surveillance radar coverage permits it, an air traffic controller may provide a surveillance radar approach if no alternative method of approach is available. The pilot must declare an emergency and request a surveillance radar approach.

NOTE:

Transport Canada radars are not flight-checked or commissioned for surveillance approaches, nor are Transport Canada controllers specifically trained to provide them.

4.6.9 RNAV APPROACHES

At the time of publication, there were two types of approved *non-precision* RNAV approaches: Multi-sensor and Global Positioning System

(GPS). Article 2.2.9 D and G provides details on the required equipment and method of operation. Once differential GPS facilities are installed in Canada, it should be possible to fly *precision* approaches using GPS. See *AIP Canada* for current information.

A. GPS APPROACHES

There are two categories of GPS non-precision approaches (NPAs) - *overlay* and *stand-alone*. Traditional NAVAIDS (VOR, NDB) need not be monitored when flying a GPS stand alone NPA as long as certain conditions are met.

The GPS overlay approach uses an existing NPA - VOR, VOR/DME, NDB, NDB/DME - but the GPS is used to fly the approach. The GPS stand-alone approach is a totally new approach designed for use with GPS.

1. GENERAL PROVISIONS

- a/ The GPS avionics must meet TSO C-129 requirements or equivalent criteria, and must be installed and approved in accordance with the appropriate regulations;

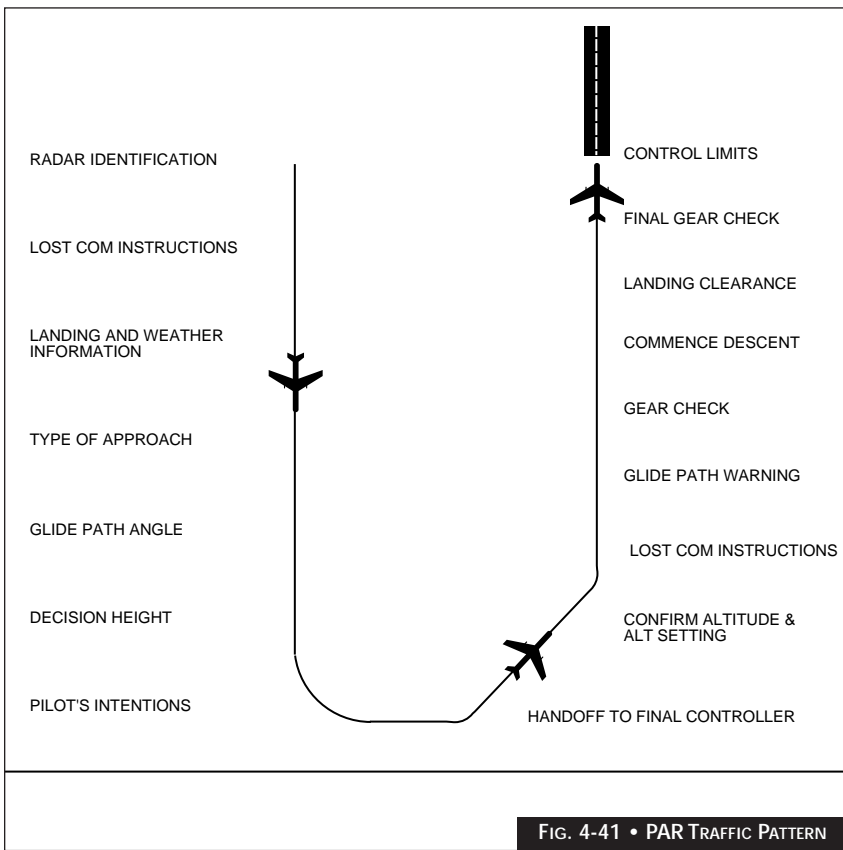

FIG. 4-41 • PAR TRAFFIC PATTERN

- b/ An approach using GPS shall not be flown unless that instrument approach is retrieved from the *avionics data base*. The GPS avionics must store the location of all waypoints, intersections, and/or navigation aids required to define the approach and present them in the order depicted on the published non-precision instrument approach procedure chart;
- c/ The general approval to use GPS to fly instrument approaches is presently limited to VOR, VOR/DME, NDB and NDB/DME as listed in *CAP*. The use of GPS for any other instrument approach procedure must be authorized.

- d/ The published approach must be identified and requested as a GPS approach (e.g. "GPS RWY 13").

NOTE:

Approaches which may be flown using GPS are listed in the Canada Air Pilot or may be provided as special approvals to individual companies.

2. GPS OVERLAY APPROACHES

- a/ The ground-based NAVAID(s) required for the published approach must be operating and the avionics for the approach must be installed and operational and *monitored* by the flight crew during the approach;
- b/ The approach must be requested and approved by its published name (e.g. "NDB RWY 24", "VOR RWY 24"). Modification of the published instrument approach identification is not required.

NOTE:

If there is a discrepancy between GPS and the traditional NAVAID(s), the pilot must revert to the traditional NAVAID(s) for navigation.

3. GPS STAND-ALONE APPROACHES

- a/ *RAIM (Receiver Autonomous Integrity Monitoring)* must be available to provide integrity for the navigation guidance used during the approach;
- b/ The ground-based NAVAID(s) that traditionally defined the published approach at the destination airport may be inoperative;
- c/ Any required alternate aerodrome must have an approved instrument approach procedure, other than GPS, which is anticipated to be operational at the estimated arrival time. The avionics to fly that approach must be installed and operational. The avionics required to

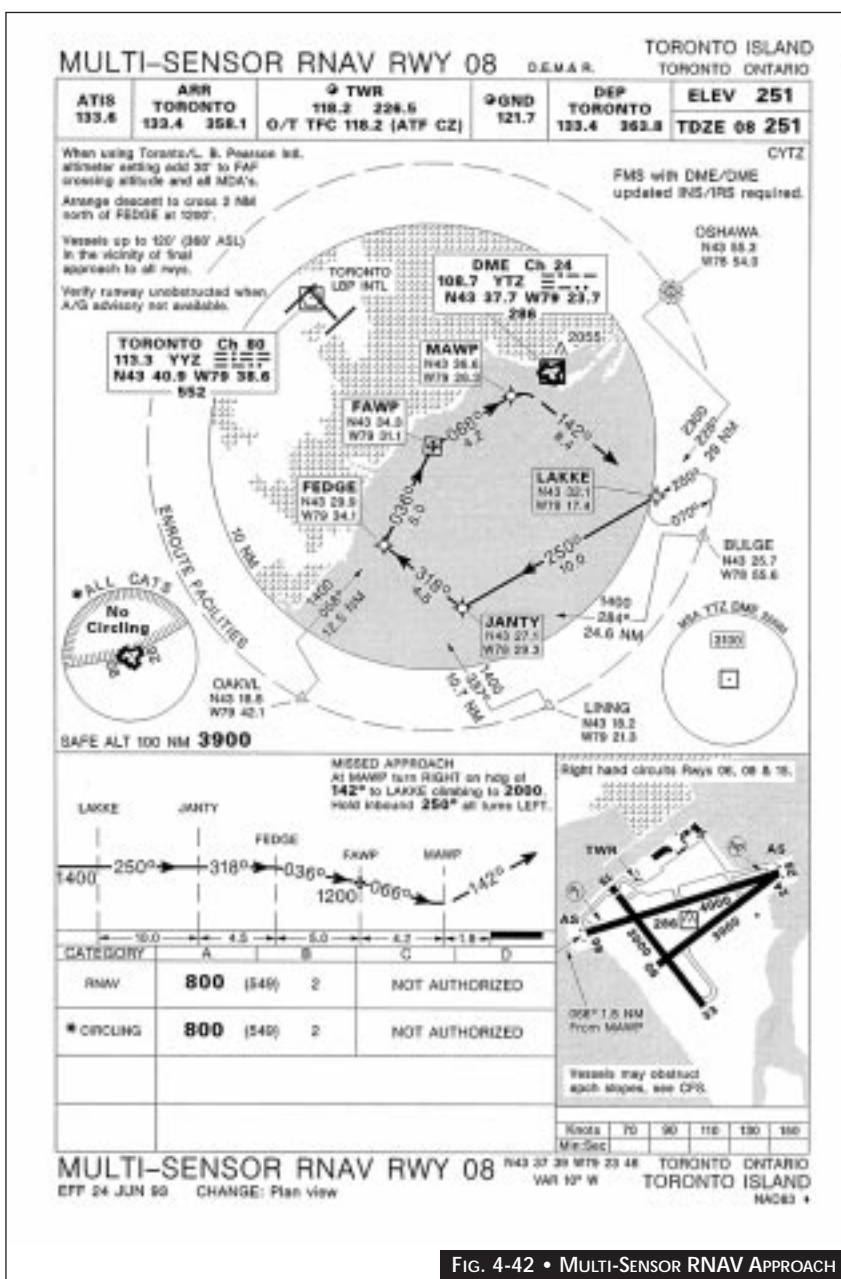

FIG. 4-42 • MULTI-SENSOR RNAV APPROACH

4. **FLYING THE GPS APPROACH:** GPS approaches should be flown like other non-precision approaches in terms of aircraft control, tracking and descents. Track guidance can be expected to be more accurate than traditional NAVAIDS, and a bonus is time, distance and groundspeed information. Trials have shown that NPAs using GPS can normally bring the aircraft within 100 ft. of centreline 1 NM back from the runway threshold.

At the time of publication of this manual, criteria for constructing and depicting RNAV procedures were still being developed by Canada and other countries. Therefore, no detailed information can be provided in this edition of the INSTRUMENT PROCEDURES MANUAL.

B. MULTI-SENSOR APPROACHES

An example of a Multi-Sensor RNAV approach is found in Fig. 4-42. It requires an FMS with INS/IRS updated by DME/DME. Notice that the minimums for this approach are a HAT (height above touchdown zone elevation) of 549 feet and a visibility of 2 NM. Also, there are a total of 5 fixes (LAKKE, JANTY, FEDGE, FAWP, MAWP) required which are arranged in a "U" pattern.

4.7 EMERGENCIES

4.7.1 DECLARATION OF EMERGENCY

Whenever pilots encounter an emergency, they must take *whatever action is necessary*. Air Traffic Control assists pilots in any way possible when they declare an emergency. Remember, if you want ATC priority, you must declare an emergency. If you advise ATC that you have "low fuel", your status does not change. However, a "low fuel emergency" gives you priority handling and service. Pilots should advise ATC, as soon as practicable, of any deviations from IFR altitudes or route required by an emergency, so that every effort can be made to minimize conflict with other aircraft. Air Traffic Control *may* ask pilots for a written report concerning the nature of a declared emergency.

The two categories of emergency are summarized:

TYPE	R/T	C/W	USAGE
1. DISTRESS	MAYDAY	SOS	1/ When threatened by serious and/or immediate danger and requiring immediate assistance (ditching, crash landing, etc.)
A distress message has priority over all other messages			2/ When transmitting distress traffic for others unable to transmit
2. URGENCY	PAN PAN	XXX	1/ When situation requires urgent action but is not actual distress (lost, fuel shortage, etc.)
An urgency message has priority over all other messages except distress			2/ When transmitting to report the safety to an aircraft, ship or other vehicle, or of some person or persons on board or within sight

THE PILOT SHOULD:

- a/ switch on all automatic emergency equipment;
- b/ precede the distress or urgency message by the appropriate signal, preferably spoken three times;
- c/ transmit on the air-ground frequency in use at that time including flight level, and heading; and
- d/ include in the distress or urgency message as many as possible of these elements:
 - 1/ MAYDAY MAYDAY MAYDAY this is a/c call sign (3 times),
 - 2/ type of aircraft,
 - 3/ position or estimated position,
 - 4/ heading and airspeed,
 - 5/ altitude,
 - 6/ nature of emergency,
 - 7/ pilot's intentions (ditching, landing, etc.).

THESE PROCEDURES DO NOT PRECLUDE:

- a/ the aircraft using any available frequency for broadcasting the emergency message;
- b/ the aircraft using any means at its disposal to attract attention and make known its condition;
- c/ any station taking any means to assist the stricken aircraft.

Generally, the pilot addresses the station that normally communicates with the aircraft.

When an aircraft does not reply when called, and is assumed to have transmitter trouble, messages to the aircraft may be *transmitted blind*. Under these conditions the message shall be repeated three times at three-minute intervals. Messages to ATC shall not be transmitted blind unless specific instructions to do so are received from the controller, or you have reason to believe that your transmitter is still functioning but your receiver is not.

Pilots of *transponder-equipped aircraft*, when experiencing an emergency and unable to establish communications immediately with an air traffic control unit, may indicate "*emergency*" to ATC by adjusting the transponder to reply on Code 7700. Thereafter, the pilot should establish radio communications with ATC as soon as possible and operate the transponder as

directed by ATC. When pilots use Code 7700, the signal will not be detected when the aircraft is outside SSR range.

4.7.2

COMMUNICATION FAILURE IN IFR FLIGHT

All pilots and operators should study the communications failure procedures in the *Canada Flight Supplement*.

- a/ If a communication failure occurs when the pilot is operating in *VFR weather conditions*, or if the aircraft subsequently encounters VFR weather conditions, the pilot shall maintain VFR and land as soon as practicable;
- b/ If the failure occurs in *IFR weather conditions*, or if the flight cannot be continued under VFR weather conditions, the pilot-in-command shall continue the flight according to the following:

1/ *ROUTE*

- i/ by the route assigned in the last ATC clearance received and acknowledged; or
- ii/ if being radar vectored, by the direct route from the point of communications failure to the fix, route, or airway specified in the vector clearance; or
- iii/ in the absence of an assigned route, by the route that ATC has advised may be expected in a further clearance; or
- iv/ in the absence of an assigned route or a route that ATC has advised may be expected in a further clearance, by the route filed in the flight plan.

2/ *ALTITUDE:* At the HIGHEST of the following altitudes or flight levels for the ROUTE SEGMENT BEING FLOWN:

- i/ the altitude(s) or flight level(s) assigned in the last ATC clearance received and acknowledged; or
- ii/ the minimum IFR altitude (see *AIP RAC* for definition); or



- iii/ the altitude or flight level ATC has advised may be expected in a further clearance. (The pilot shall commence climb to this altitude/FL at the time or point specified by ATC to expect further clearance/altitude change).

NOTE 1:

The intent of the above is that an aircraft which has experienced communications failure will, during any segment of a flight, be flown at an altitude that provides the required obstacle clearance.

NOTE 2:

If the failure occurs while being vectored at a radar vectoring altitude which is lower than the appropriate minimum IFR altitude, the pilot shall immediately climb to and maintain the appropriate minimum IFR altitude until arrival at the fix, route or airway specified in the clearance.

- 3/ **DESCENT FOR APPROACH:** Maintain en route altitude to the navigation facility or the Initial Approach Fix to be used for the instrument approach procedure selected (published transitions are included as IAFs in this case) and commence an appropriate *descent procedure* at whichever of the following times is the latest:

- i/ the expected time of arrival (ETA) as calculated from take-off time plus the filed or amended (with ATC) estimated time en route);
- ii/ the estimated time of arrival last notified to and acknowledged by ATC; or
- iii/ the expected approach time (EAT) last received and acknowledged.

If failure occurs after receiving and acknowledging a *holding instruction*, hold as directed and commence an instrument approach at the expected approach time or expected further clearance time, whichever has been issued.

NOTE 1:

If the holding fix is not a fix from which an approach begins, leave the fix at the expected further clearance time if one has been received, or, if none has been received, upon arrival over the clearance limit and proceed to a fix from which an approach begins and commence descent or descent and approach as close as possible to the estimated time of arrival as calculated from the filed or amended (with ATC) estimated time en route.

NOTE 2:

If cleared for a STAR or profile descent procedure, maintain the appropriate altitude described in paragraph 2 (Altitude) and proceed to the final approach fix via:

- i/ the published routing (and altitudes in the case of a profile descent); or
- ii/ the published route to the segment where radar vectors are depicted to commence, then direct to the facility serving the runway advised by ATIS or specified in the ATC clearance, for a straight-in approach, if able, or to conduct the full procedure as published.

- c/ *Pilots of transponder-equipped aircraft, when experiencing a two-way communications failure, shall indicate the situation to ATC by selecting Code 7600. This only indicates the situation, and does not relieve the pilot of the requirement to comply with the published communications failure procedures.*

NOTE:

When a pilot uses Code 7600, ATC may not detect the signal because the aircraft is not within SSR coverage or because the ATC unit is using SSR equipment that does not automatically detect Code 7600.

Should a situation develop for which there is *no set procedure* or where other circumstances warrant it, the pilot shall act according to his or her own best judgement. In any event, ATC protects the airspace required to conduct any instrument approach at the aerodrome of first intended landing for a period of 30 minutes from the time at which the aircraft is expected to commence an approach.

4.7.3

REPORTING MALFUNCTIONS OF NAVIGATION AND COMMUNICATIONS EQUIPMENT

The pilot of an IFR aircraft within controlled airspace shall report immediately to the appropriate Air Traffic Control unit any malfunction of navigation or air/ground communications equipment, e.g.:

- a/ loss of VOR, ADF or other navigation capability;
- b/ complete or partial loss of ILS capability;
- c/ complete or partial loss of INS/ONS/GPS capability;
- d/ impairment of air/ground communications capability; or
- e/ impairment of transponder operation.

After receiving this information, ATC takes into account any limitations in navigation or air/ground communications equipment and issues control instructions accordingly.

4.7.4

FUEL DUMPING

Whenever it is necessary to jettison fuel, the pilot should immediately notify ATC and provide information on the track to be flown, period of time involved, and weather conditions. ATC may suggest an alternate area where fuel should be dumped; aircraft should dump fuel on a constant heading over unpopulated areas and clear of heavy traffic. To allow for adequate vaporization, fuel dumping should be carried out at least 2000 ft. above the highest obstacle within 5 NM of the track to be flown. After obtaining the necessary information, ATC broadcasts a "fuel dumping" advisory on appropriate frequencies at three-minute intervals, until 15 minutes after the aircraft completes the fuel dumping. Pilots should advise ATC immediately after the dumping has been completed.

4.8

TRANSPONDER OPERATION

4.8.1

GENERAL

When pilots receive ATC instructions concerning transponder operation, they shall operate transponders as directed until receiving further instructions or until the aircraft has landed, except in an *emergency, communication failure or hijack*.

Air Traffic Control radar units have an *alarm system* that responds when the aircraft is within radar coverage and when the pilot selects the emergency, communication failure or hijack transponder code. Pilots may unintentionally select these codes momentarily when changing the transponder from one code to another. To avoid unnecessary activation of the alarm, pilots should avoid inadvertent selection of 7500, 7600 or 7700. This can be accomplished by simply avoiding selection of the left-hand "7" on the transponder head. If a "7" must be used, such as in Code 7215, additional care must be taken. Do not select "standby" while changing codes, as this will cause the radar target to be lost.

Pilots should adjust transponders to "*standby*" while taxiing for take-off, to "*on*" (or "*normal*") as late as practicable before take-off, and to "*standby*" or "*off*" as soon as practicable after completing the landing. Pilots shall operate the identification (IDENT) feature only when directed by ATC. Mode C altitude reporting should always be used when available. On initial contact with departure control, advise altitude to the nearest 100 ft. increment so that ATC may validate their altitude readout.



FIG. 4-43 • DIGITAL TRANSPONDER



4.8.2 HIGH-LEVEL AIRSPACE - IFR FLIGHT

Transponders shall be operated as directed by ATC, or if no direction is given by ATC, adjusted to reply on *Code 2000* and on Mode C.

A transponder is required for operations within controlled high-level airspace. A controller, however, may authorize an aircraft without a serviceable transponder to operate in controlled high level airspace provided that the pilot files a written request with an ATC unit or other flight plan office. The pilot may include this request in a flight plan. An aircraft normally may continue to operate in controlled HLA to the next point of intended landing if its transponder fails in flight.

Air Traffic Control may refuse a request or cancel a previously issued authorization if traffic conditions or other operational requirements dictate.

4.8.3 LOW-LEVEL AIRSPACE - IFR FLIGHT

Pilots shall operate transponders as directed by ATC, or if no direction is given by ATC, adjust to reply on *Code 1000* and on Mode C. If the pilot cancels the IFR flight plan, the transponder should be adjusted to reply on the appropriate VFR code specified below, unless otherwise directed by ATC.

4.8.4 PHRASEOLOGY

SQUAWK (number):

Operate transponder on specified code in Mode A.

SQUAWK IDENT:

Activate the identification ("IDENT") feature of the transponder.

SQUAWK (number) AND IDENT:

Operate transponder on specified code and activate the "IDENT" feature.

SQUAWK STANDBY:

Switch transponder to "standby" position, retaining present mode and code.

SQUAWK LOW/NORMAL:

Operate transponder on low or normal sensitivity as specified. (Transponder is operated on normal sensitivity unless ATC specifies "low". "ON" is used instead of "NORMAL" as a label on some transponder control panels. Some transponders do not have a "LOW" setting).

SQUAWK MAYDAY, CODE SEVEN SEVEN ZERO ZERO:

Operate transponder on, Code 7700.

STOP SQUAWK:

Switch off transponder.

STOP ALTITUDE SQUAWK:

Turn off altitude reporting equipment.

4.8.5 MODE C

Flight crews of aircraft with transponders capable of Mode "C" (automatic altitude reporting) shall adjust their transponders to transmit Mode "C" when operating in Canadian airspace unless de-activation is directed by ATC. Certain classes of airspace normally require Mode "C" operation for both IFR and VFR aircraft. See the *AIP, CFS* or *Designated Airspace Handbook* for details. Mode S transponders are discussed in Article 2.1.6D.

4.8.6 VFR FLIGHT (INCLUDING CONTROLLED VFR FLIGHT)

Unless otherwise directed by ATC, pilots should operate transponders on one of the following codes, as appropriate:

- a/ *Code 1200*, for operation below 12,500 ft ASL;
- b/ *Code 1400*, for operation at or above 12,500 ft ASL.

NOTE:

When climbing above 12,500 ft, pilots should use Code 1200 until they leave 12,500 ft, then select Code 1400. When descending from 12,500 ft or above, pilots should select code 1200 upon reaching 12,500 ft.

4.8.7 EMERGENCIES

In the event of emergency, and if unable to establish communication immediately with an ATC unit, a pilot wishing to alert ATC to the emergency situation should adjust the transponder to reply on *Code 7700*. Thereafter, the pilot should establish communication with ATC as soon as possible, and operate the transponder as directed by ATC.

4.8.8 COMMUNICATION FAILURE

In the event of a communication failure, the pilot should follow the procedures set forth in the *Canada Flight Supplement* including setting the transponder to *Code 7600*. Article 4.7.2 and *AIP Canada* provide further details.

4.8.9 UNLAWFUL INTERFERENCE (HIJACK)

Canada, along with other nations, has adopted a special SSR transponder code for use by pilots whose aircraft are hijacked. Air Traffic Control does not assign this code (*7500*) unless the pilot informs ATC of a hijack in progress.

Selection of the code activates an alarm and points out the aircraft on radar displays. If the controller doubts that an aircraft is being hijacked (as could occur when a code change was requested and the hijack code appeared, rather than the assigned code), the controller should say YOU ARE SQUAWKING SEVEN FIVE ZERO ZERO, IS THIS INTENTIONAL? If the pilot says no, the controller re-assigns the proper code.



**P
A
R
T
F
I
V
E**

HELICOPTER ATTITUDE INSTRUMENT FLYING

- 5.1 DEFINITIONS
- 5.2 THEORY
- 5.3 ATTITUDE AND POWER CONTROL
- 5.4 STABILIZATION SYSTEMS
- 5.5 INSTRUMENT FLIGHT
- 5.6 HELICOPTER APPROACHES
- 5.7 EMERGENCIES



HELICOPTER ATTITUDE INSTRUMENT FLYING

The contents of this part describe the performance of basic instrument manoeuvres for helicopters in instrument meteorological conditions (IMC).

5.1 DEFINITIONS

1. *APPROACH PHASE:* That part of the flight from 300 m. (1000 ft) above the landing surface or above if the flight is planned to exceed this height, or from the commencement of the descent in the other cases, to landing or to the missed approach point.
 2. *CATEGORY A:* With respect to transport category rotorcraft, means multiengine rotorcraft designed with engine and system isolation features specified in the *Airworthiness Manual Chapter 529* and utilizing scheduled takeoff and landing operations under a critical engine failure concept which assures adequate designated surface area and adequate performance capability for continued safe flight in the event of engine failure.
 3. *CATEGORY B:* With respect to transport category rotorcraft, means single-engine or multiengine rotorcraft which do not fully meet all Category A standards. Category B rotorcraft have no guaranteed stay-up ability in the event of engine failure and unscheduled landing is assumed.
 4. *DEFINED POINT BEFORE LANDING:* The point, within the approach phase, after which the helicopter's ability to continue the flight safely, with one engine inoperative, is not assured and a forced landing may be required.
 5. *DEFINED POINT AFTER TAKE-OFF:* The point, within the take-off or initial climb phase, before which the helicopter's ability to continue the flight safely, with one engine inoperative, is not assured and a forced landing may be required.
 6. *ELEVATED HELIPORT:* A heliport located on a raised structure on land.
 7. *EN ROUTE PHASE.* That part of the flight from the end of the initial climb phase to the commencement of the approach phase.
- NOTE:**
Where adequate obstacle clearance cannot be guaranteed visually, flights must be planned to ensure that obstacles can be cleared by an appropriate margin. In the event of failure of a power-unit, operators may need to adopt alternative procedures.
8. *FINAL APPROACH AND TAKE-OFF AREA (FATO) FOR HELICOPTERS:* A defined area over which the final phase of the approach manoeuvre to hover or landing is completed and from which the take-off manoeuvre is commenced and, where the FATO is to be used, includes the rejected take-off area available.
 9. *HELICOPTER:* A heavier-than-air aircraft supported in flight by the reactions of the air on one or more power-driven rotors on substantially vertical axes.
 10. *HELIDECK:* A heliport located on an offshore structure, either floating or fixed.
 11. *HELIPORT:* An aerodrome or a defined area intended to be used wholly or in part for the arrival, departure and surface movement of helicopters.
 12. *INITIAL CLIMB PHASE:* That part of the flight from the end of the take-off phase up to 300 m (1000 ft) above the take-off surface if the flight is planned to exceed this height, or to the end of the climb in the other cases.
 13. *INSTRUMENT METEOROLOGICAL CONDITIONS (IMC):* Meteorological conditions expressed in terms of visibility, distance from cloud and ceiling, less than the minima prescribed in the *Air Regulations* for flight in VFR weather.
 14. *LANDING DECISION POINT (LDP):* The landing decision point is the point used in determining landing performance from which, any emergency condition occurring at this point, the landing may be safely continued or a missed approach initiated.
 15. *LANDING DISTANCE REQUIRED:* The

horizontal distance required to land and come to a full stop from a point 10.7 m (35 ft) above the landing surface.

16. *MISSED APPROACH PHASE*: That part of the flight from the point where the missed approach procedure is initiated up to 300 m (1000 ft) above the intended landing surface, or to the level-off height if this is below 300 m (1000 ft).
17. *REQUIRED VISUAL REFERENCE*: In respect of an aircraft on an approach to a runway, means that section of the approach area of the runway or those visual aids that, when viewed by the pilot of the aircraft, enables the pilot to make an assessment of the aircraft position and the rate of change of position relative to the nominal flight path.
18. *REJECTED TAKE-OFF DISTANCE REQUIRED*: The horizontal distance required from the start of the take-off to the point where the helicopter comes to a full stop following any emergency condition that requires rejection of the take-off at the take-off decision point.
19. *SAFE FORCED LANDING*: Unavoidable landing or ditching with a reasonable expectancy of no injuries to persons in the aircraft or on the surface.
20. *TAKE-OFF PHASE*: That part of the flight from the start of take-off up to the point where the helicopter achieves VTOSS, a positive rate of climb and height of not less than 10.7 m (35 ft).
21. *TAKE-OFF DECISION POINT (TDP)*: Take-off decision point is the point used in determining take-off performance from which any emergency condition occurring at this point, either a rejected take-off may be made or a take-off safely continued.
22. *TAKE-OFF DISTANCE REQUIRED*: The horizontal distance required from the start of the take-off to the point at which VTOSS, a height of 10.7 m (35 ft) above the take-off surface, and a positive climb gradient are achieved, following any emergency condition at TDP, with the remaining power-unit(s) operating within approved operating limits.
23. *VISUAL METEOROLOGICAL CONDITIONS VMC*: Meteorological conditions expressed in terms of visibility, and distance from cloud, equal to or greater than the minima prescribed in the *Air Regulations* for flight in VFR weather.
24. *VTOSS*: The minimum speed specified in the flight manual at which climb can be achieved, in the take-off configuration, with one or more power-unit(s) inoperative, and the remaining power-unit(s) operating within approved operating limits. It guarantees, under ambient conditions, a positive rate of climb.
25. *VYI*: Instrument climb speed, utilized instead of VY for compliance with the climb requirements for instrument flight.
26. *VNEI*: Instrument flight never exceed speed, utilized instead of VNE for compliance with maximum limit speed requirements for instrument flight.
27. *VMINI*: Instrument flight minimum speed, utilized in complying with minimum limit speed requirements for instrument flight.



5.2 THEORY

Attitude instrument flying is essentially visual flying with the flight instruments substituted for the various reference points around the helicopter and the natural horizon. In flight the instruments provide information concerning: 1) helicopter attitude; 2) power required; and 3) whether the combination of attitude and power is providing the desired performance.

Instrument flying in either category of aircraft (fixed wing and rotary wing) have similarities, but generally only while in level cruising flight. Distinctive performance characteristics and the intrinsic *instability* of most helicopters (except those with *stability augmentation systems*) limit the amount of time that is spent in a stable flight condition. Unlike fixed wing, in helicopters both lift and thrust originate from a single source, the main rotor.

As airspeed is reduced in a *transition* (below 60 kts) from forward flight to the hover, the pitot-static instruments become less reliable. As well as the low airspeeds, reduced stability overall is the consequence. Manufacturers of IFR certified twin-engine helicopters specify minimum IMC control speeds (V_{mini}) for the purpose of stability and certification. *Minimum airspeeds* at which the helicopter can sustain flight with one-engine inoperative (OEI) are also prescribed. Prolonged flight below these minimum airspeeds is not recommended, except as required for special purpose operations. These unique traits demand an alternate method of interpretation and use of the instruments common to both categories of aircraft.

The use of *attitude* (relative to the horizon) *plus power equals performance* theory is taught as the fundamentals of visual attitude flying. Instrument attitude flying builds on this basic visual principle. Throughout this section there are discussions of the relationship between flight controls and control and performance instruments. Control inputs required to produce a given attitude by reference to instruments are identical to those used in visual meteorological conditions (VMC).

The manoeuvres discussed in this section are designed to develop proficiency in the attitude control of helicopters and are the first step towards safe all weather operation.

5.3 ATTITUDE AND POWER CONTROL

ATTITUDE CONTROL

The attitude of the helicopter is controlled by movement around its *pitch* (lateral), *roll* (longitudinal), and *yaw* (vertical) axes. The three helicopter flight controls are:

CYCLIC :

- i/ *Pitch Attitude Control.* The movement of the helicopter about the lateral axis involves changing the longitudinal tilt of the main rotor disc (cyclically - each blade changes once per revolution).
- ii/ *Bank Attitude Control.* The movement of the helicopter about the longitudinal axis involves controlling the angle made by lateral tilt of the rotor disc and the natural horizon.

COLLECTIVE:

Power/Thrust Control. Altering collective pitch (thrust/lift) results in a collective change of



FIG. 5-1 • LANDING ON A RIG

angle of attack of the rotor blades i.e. all rotor blades change pitch together - or collectively.

PEDALS.

Co-ordinated Flight and Trim. Pedal co-ordination to compensate for all power changes.

POWER CONTROL

As previously mentioned both lift and thrust originate from a single source, the *main rotor*. To properly change or maintain any desired attitude a pilot should know the appropriate steady state flight power settings required for that particular helicopter, i.e. standard day sea level, a medium twin-engine helicopter with two crew and full fuel required approximately 62% torque (Q) for straight and level flight at 100 kt. Power settings for standard (500 fpm) climbs and descents should also be determined.

Power settings are controlled via the collective lever and displayed by the torque meter. The primary and secondary effects of a collective control movement are the same as for VFR. When power is added, the nose will pitch up and yaw right (North American rotation). The converse is true when the collective is lowered. In most IFR helicopters the stabilization system if used, will compensate for the secondary effect of power changes (Dutch roll). *Failure of the autopilot in IMC can result in loss of control.*

At a given airspeed, specific power settings determine whether the helicopter is climbing, descending, or in level flight. Increasing the power while maintaining a constant airspeed results in a climb, while decreasing the power has the opposite effect.

At a constant altitude, the power will determine the airspeed. When power is increased, the nose will have to be pitched down to maintain altitude, then the airspeed increases. The converse applies when the power is decreased.

Constant altitude and airspeed in level flight are predicated on co-ordination of pitch attitude and power.

When power is adjusted for airspeed or altitude the helicopter attitude will be affected; the amount and direction depends on the change made or required. Pitch and bank must be adjusted and yaw eliminated to maintain co-ordinated flight.

A. CONTROL AND PERFORMANCE INSTRUMENTS.

The control and performance instruments are grouped as follows:

Control instrument interpretations are made by reference to the:

- a/ attitude indicator; and
- b/ torque meter.

Performance instruments display the effects of the control instrument changes on the helicopter flight path on the following instruments:

- a/ airspeed indicator (ASI),
- b/ altimeter,
- c/ vertical speed indicator (VSI),
- d/ heading indicator or compass (HSI/DG), and
- e/ turn and bank indicator.

Corrections made with reference to the control instruments are made on the basis of information received from the performance instruments.

Employment of the control and performance theory apply for all instrument manoeuvres; *cyclic* (attitude) controls airspeed and *collective* (power) controls altitude or rate of altitude change. Variation of the pitch attitude (*cyclic*) in flight has an immediate effect on airspeed and as a by-product a change in altitude. A



FIG. 5-2 • ARCTIC OPERATIONS



change in power (collective) will have an immediate effect on lift (altitude) and a lesser effect on thrust (airspeed).

The interpretation of the attitude indicator in helicopter instrument flying must also be discussed. The attitude indicator in a helicopter displays *fuselage attitude* and *not disc attitude*. A helicopter can climb or descend with a nose up, down or level attitude. In level cruising flight each different attitude yields a different airspeed, assuming constant power. The attitude indicator is the only instrument that provides a direct indication of attitude. However, it does not always represent disc attitude and therefore does not accurately display what the helicopter is doing. For example the attitude indicator may show a nose up attitude while in reality the helicopter is descending at 90 kts. The attitude indicator should always be cross checked with the performance instruments, especially the VSI and altimeter, to ensure valid information.

At a given airspeed the power setting determines whether the helicopter is climbing, descending or in level flight. Conversely, if the altitude is held constant, the power and attitude settings will determine whether airspeed is increasing, decreasing or constant.

The relationship between varying power and attitude is so homogeneous that the true culprit of a deviation in airspeed, altitude or heading is not always apparent. The heading or altitude can change without a corresponding change in attitude. Correct interpretation of information provided by the attitude indicator alone is often a difficult process. This demands correct interpretation of all control and performance instruments for stable, co-ordinated instrument flight.

B. PITCH ATTITUDE CONTROL

PITCH CONTROL: The performance instruments for pitch control reference are:

- a/ attitude indicator (control);
- b/ altimeter;
- c/ vertical speed indicator; and
- d/ airspeed indicator.

ATTITUDE INDICATOR: The attitude indicator provides general pitch information and is used

in conjunction with the other pitch instruments. In level flight at normal cruise airspeed, the miniature aircraft should be superimposed on the horizon bar. If the miniature aircraft rises above the horizon, the VSI and altimeter should confirm a climb and the airspeed should decay. Small gains or losses of altitude are made by pitching the nose up or down slightly. Small pitch attitude changes should not exceed 1 1/2 bar widths, and the performance should be cross-checked against the other pitch instruments. If larger pitch changes are required power will likely have to be adjusted.

ALTIMETER: The altimeter provides indirect pitch information in level cruising flight. Since the helicopter can ascend or descend in level cruising flight without a pitch change, the altimeter should be used in conjunction with the other pitch instruments. The altimeter was not designed as a rate instrument and therefore is of limited value in this capacity. Fixating on this instrument can lead to "chasing" and overcontrolling if it is used as the sole reference for pitch.

VERTICAL SPEED INDICATOR (VSI): The VSI is a essentially a trend instrument and should always be used in conjunction with the other pitch instruments. In level cruising flight the needle indicates zero. Use the VSI together with the altimeter to correct deviations from level flight. Since there is a time element (lag) associated with the VSI (except IVSI), fixating on this instrument can end in "chasing" the indications, jeopardizing pitch control.

Over-correction using the VSI leads to overcontrolling. As a rule pitch attitude change should produce a rate of change on the VSI about twice the altitude deviation (max 500 fpm) ie: if the helicopter is 200 feet off altitude desired, a correction of not greater than 400 fpm should be used.

When changing altitudes at specific rates and the VSI shows an excess of 200 fpm from that desired, over-controlling is indicated.

To eliminate over-controlling, neutralize the controls, allow the pitch attitude to stabilize and readjust pitch attitude with the other pitch instruments.

INSTANTANEOUS VERTICAL SPEED INDICATOR (IVSI): Most IFR certificated helicopters in today's IFR environment are equipped with an IVSI. The design of the IVSI can assist the pilot flying IFR as it is an effective pitch instrument. Compared to the conventional VSI, this instrument has no apparent lag. Although similar in construction, the IVSI incorporates accelerometers which generate pressure differences when the normal acceleration of the helicopter is changed. A word of caution however as fixation on any one instrument in IFR flying can lead to disastrous consequences. Correct interpretation of the helicopter pitch attitude requires use of all pitch instruments through a *comprehensive cross-check*.

AIRSPED INDICATOR (ASI): Airspeed is a function of power setting and attitude (refer to Article 5.3). Experience on type teaches the pilot approximate power settings for desired airspeeds. In level cruising flight if airspeed increases, the nose is low, and should be raised. If airspeed decreases the nose is too high and should be lowered. Rapid changes in airspeed imply large changes in pitch attitude. Conversely, small changes represent small changes in pitch attitude. When making attitude changes, an apparent lag may be observed, this will be a function of the time required to accelerate/ decelerate. Some helicopter types will be subject to further aggravation by *cyclic control lag*. Departure from a constant airspeed due to an inadvertent pitch change results in an altitude change, i.e. an increase in airspeed due to low pitch attitude will result in a decrease in altitude. Correcting the pitch attitude regains both airspeed and altitude.

C. BANK ATTITUDE CONTROL

BANK CONTROL: Assuming co-ordinated level flight, any departure from a laterally level attitude produces a turn. The performance instruments used for bank control are:

- a/ attitude indicator (control);
- b/ heading indicator; and
- c/ turn and bank indicator.

ATTITUDE INDICATOR: Changes in bank attitude are indicated by the miniature aircraft on the

attitude indicator. Banking is shown by the miniature aircraft wings assuming an angle in relation to the horizon bar and by the bank - index pointer moving from the zero position to the angle-of-bank reference marks. For proper interpretation imagine being in the miniature aircraft on the attitude indicator. *Cyclic* is used to tilt the rotor disk to the required angle of bank; the cyclic position has then to be maintained to hold the desired bank angle. The ball should remain centred in the turn. To return to level flight the above procedure is reversed. Small bank angles may not be readily detected on the attitude indicator but can be determined by reference to the heading indicator and turn and bank indicator.

HEADING INDICATOR: Although the heading indicator gives an immediate indication of turning, its primary purpose is to indicate heading, not bank angle. In co-ordinated flight when the helicopter is banked, it turns. When the heading indicator shows a constant heading (laterally level) you are flying straight. Small bank angles show up as slow changes of heading; large bank angles indicate rapid heading changes. To correct a turn apply cyclic in the desired direction until the desired heading is reached, maintain co-ordinated flight with pedals. Use a bank angle not greater than the number of degrees off heading up to a *maximum of a standard rate-one turn* to initiate or correct a turn.



FIG. 5-3 • TYPICAL HELICOPTER INSTRUMENT PANEL



TURN AND BANK INDICATOR

TURN NEEDLE: The turn needle indicates both direction and rate of turn. When the needle is left of centre and the ball is centred, the helicopter is turning left. Correcting the needle back to the centre position with opposite cyclic restores straight flight. In *turbulent conditions* needle oscillations must be averaged to detect a turn. If the needle deflection is greater to the right, the helicopter is turning right.

TURN AND BANK BALL: The ball functions as result of gravity and centrifugal force. Although the needle and ball are interpreted together, the ball indicates whether the helicopter is yawing (slipping or skidding). In a *slip* the ball is off-centre toward the inside of the turn (primarily gravity). In a *skid* the ball is off-centre toward the outside of the turn (centrifugal force). The ball shows quality of control co-ordination whether turning or in straight flight. In a helicopter the displacement of the ball to one side of centre necessitates pedal adjustment. To keep the helicopter from turning, cyclic must be moved in the opposite direction. This *cross-controlling* (cyclic countering yaw) is uncomfortable, adds airframe stress and may contribute to vertigo.

The ball instrument aids in achieving correct co-ordination. In helicopters proper co-ordination is realized by proper use of the anti-torque pedals and the cyclic in relation to each other.

TURN CO-ORDINATOR: This instrument displays movement of the helicopter on the roll axis that is proportional to the roll rate. When the roll rate is reduced to zero, the instrument provides an indication of the rate of turn. It should be clearly understood that the miniature aircraft of the turn co-ordinator displays only rate of roll and rate of turn. It does not directly display the bank angle of the aircraft.

D. TRIM TECHNIQUES

The intrinsic instability of helicopters require the pilot to employ trim as accurately as possible

to minimize fatigue and reduce pilot workload. The perfection of instrument flying skills depends to a great extent upon how well a pilot learns to keep the helicopter in trim.

Maintaining trim is achieved by continual cross-checking using cyclic force trim (if so equipped), with reference to the instruments, to cancel undesired cyclic pressures. Releasing the force trim simultaneously disengages all axes and the pilot must ensure that those axes not requiring a change are maintained while corrections to the desired axes is achieved. "*Step on the ball*" with pedals and trim out control pressures while ensuring that attitude and heading are maintained for the desired state of flight. Pilots flying helicopters equipped with the "Chinese Hat" trim button on the cyclic use small trim changes in the desired direction until control pressures are neutralized; i.e. trimming nose up/down (pitch) and left/right (roll).

The *YAW* axis is the most unstable axis in a single-rotor helicopter. This axis demands special attention from the pilot when flying IMC. The instability is compounded as any power change requires a pedal trim correction to centre the ball of the turn indicator. Undesirable yaw under IMC is the contributing factor leading to spatial disorientation and the associated hazardous illusions.

E. INSTRUMENT CROSS-CHECK

Monitoring and interpreting the various flight and navigation instruments to determine attitude and performance of a helicopter is called a cross-check or *scan*.

There are as many variations in cross-check technique as there are helicopter types. Therefore, the instruments which provide the best information for controlling the helicopter in any given manoeuvre should be used. The important instruments are the ones that provide the most pertinent information for any particular phase of the manoeuvre. These are the instruments that should be held at a constant indication. The remaining instruments should help maintain the important instrument(s) at the desired indications.

A meaningful cross-check should include the flight and navigation instruments once each scan cycle. Due to the helicopters' ability to

climb, descend and change heading without a corresponding change in attitude, the cross-check is hampered if prolonged "eye rest" on the attitude indicator is employed. An equal amount of time is required checking heading indicator and altimeter. These two instruments will show deviations that may not be readily apparent when using the attitude indicator as a place of eye rest.

The relative position of the heading indicator, altimeter and/or VSI to the attitude indicator will determine the specific cross-check in use. The eyes may be required to move constantly from ADI to HSI/DG and return to the ADI. Other configurations allow "eye rest" on the ADI briefly but continue to monitor the remaining instruments via peripheral vision.

A cross-check that requires continuous eye movement to be effective, rapidly contributes to pilot fatigue in a brief time (30 minutes or less). A cross-check that incorporates "eye rest", but still fulfils the primary function of detecting deviations is the most desirable.

5.4 STABILIZATION SYSTEMS

Stability Control Augmentation System (SCAS) is short term stability.

The primary purpose of SCAS is to improve overall helicopter stability thus reducing pilot workload and fatigue. This is achieved by a system of rate gyros that generate electrical impulses to control hydraulic or electrical actuators. These actuators compensate for outside influences i.e. turbulence, and resist deviation from the desired reference attitudes. The system may be further enhanced by using comparative electrical signals referenced as a function of stick position (via beep trim) or motion which cancel electrical signals coming from the rate gyros. Certain manufacturers utilize a motorized "jack screw" or a composite electric/hydraulic valve in series with pilot valves on the hydraulic power actuator. SCAS installations generally incorporate a limit of authority of the SCAS actuator. If a gyro suddenly sends a hardover signal, the control motion is limited and the pilot can regain

control i.e. SCAS authority 10% pitch and roll, 5% yaw.

Automatic Flight Control System (AFCS) is long term stability.

With AFCS, the SCAS system progressed one step further to "hands off" helicopter flying. With SCAS, the pilot has to keep checking and making correction inputs via the "beep trim" or "force trim" button to maintain the desired attitude. In advanced applications the AFCS uses a computer to combine electrical impulses from various sensing locations and memorizes their relative positions. It is then a simple task for the computer to reference selected control positions and cancel outside inputs, i.e. gusts, turbulence etc. The pilot now becomes a manager of the computer and auto-pilot, reducing workload and fatigue even further.

5.5 INSTRUMENT FLIGHT

INSTRUMENT CHECK

The ability to complete a full instrument check as indicated below will depend on the suitability of the ground and weather conditions:

- a/ check the helicopter heading by outside reference and the magnetic or gyro compass;
- b/ set the attitude indicator to the zeroed position;
- c/ apply collective smoothly until helicopter becomes light on the skids but still is in ground contact;
- d/ lift into hover. If hampered by surface-obscuring phenomena, carry out as much of check as conditions permit;
- e/ check torque indications and all engine and drive train indications for responses appropriate to power applied;
- f/ perform hover turn 30 degrees to left and 30 degrees to right and check the following:
 - 1/ direction indicators including standby compass for correct turn indication,
 - 2/ navigation aids tracking while turning,
 - 3/ turn needle indicates correct turn



direction and slip indicator (ball) is free moving, and

4/ VSI zero; and

- g/ from a stable hover increase collective to initiate a height gain. Check VSI and altimeter indications;
- h/ initiate a slight roll to the left or right and check the main attitude indicator for correct bank indications;
- j/ at the increased height gained, induce a slight pitch up or down and check the main attitude indicator for correct pitch indications; and
- k/ return helicopter to the ground and complete pre-departure check and pre-take-off check.

INSTRUMENT TAKE-OFF (LAND BASED)

a/ An instrument take-off (ITO) may be accomplished *from a hover* or *from the ground* as visibility restrictions permit (sand, snow). The ITO is a composite visual/instrument procedure, assuming a two pilot crew cockpit. The take-off must be completed with one pilot on instruments and the other on the outside visual references.

b/ The *ITO is accomplished as follows* (as appropriate to type):

- 1/ set the attitude indicator horizon bar for the normal take-off position of your type of helicopter. The helicopter should be aligned with the runway or approved departure route (helipad or restricted area). To prevent forward movement on wheel equipped helicopters, use brakes as necessary. Apply sufficient collective friction to minimize the overcontrolling tendency and prevent collective pitch creeping. Application of excessive friction should be avoided so as not to inhibit pitch control movement;
- 2/ re-check all instruments to determine readiness for departure. Initiate the take-off by raising the collective/thrust lever to bring the aircraft light on the wheels/skids. In a stable position check the power requirement and C of G if airborne. Apply a predetermined power

setting for that type of helicopter (consider weight, altitude and temperature), of more than that required to hover to gain altitude over airspeed (not to exceed maximum allowable power). Forward cyclic starts the acceleration to climbing airspeed; and pedals are used initially to maintain the desired heading. Ensure that there is a positive rate-of-climb before transitioning into forward flight (altitude over airspeed). *Early rotation* of the helicopter, before a positive rate of climb is established, can and has resulted in helicopter accidents. The vertical speed indicator initially and then the altimeter should be monitored for a positive rate-of-climb schedule. While the helicopter is below the minimum airspeed required for accurate and reliable airspeed determinations, the predetermined power setting and pitch attitudes will provide the most reliable source of climb path information. The attitude of the helicopter as referenced from the ADI should be one to two bar widths below the horizon. *Do not enter IMC prior to V_{mini}*;

- 3/ at a safe minimum altitude, accelerate to the minimum safety take-off speed. As the recommended climb airspeed is reached, adjust power and attitude to achieve a 500 ft/min rate of climb and transition to fully coordinated flight;
- 4/ a rapid cross-check must be started as the helicopter leaves the ground and should include all available instruments.

NOTE:

Departure criteria use 400 ft AGL as the minimum recommended obstruction clearance altitude before commencing a turn under IMC day. Circling MDA provides a minimum of 300 feet above all obstacles within the visual manoeuvring area for each category.

STRAIGHT CLIMB

a/ The phase of flight between the ITO and level off at cruise altitude generally consists of adherence to a missed approach

procedure, a SID, radar vectors or ATC clearances. Straight climbs are also entered from straight and level cruising flight. The climb under instrument conditions is performed using the *attitude-power-trim (APT)* technique.

- b/ Power is set in a climb to produce a minimum of 500 ft/min rate-of-climb, which is produced and maintained by collective pitch. As power is increased, a correction for trim is made with pedals.
- c/ During the climb, heading, attitude and airspeed are maintained with cyclic. Rate-of-climb is controlled by collective (power) and trim with pedals. Although the amount of lead varies with the aircraft, rate-of-climb and pilot technique, a lead of 10% of the rate-of-climb is generally accepted as the point to initiate levelling off at the desired altitude.
- d/ To resume level flight at normal cruise use the *attitude, power and trim (APT)* technique. The cyclic is adjusted to establish the desired attitude and normal cruise airspeed then the collective (power) pitch is set for cruising flight, then re-trimmed as necessary.

STRAIGHT AND LEVEL FLIGHT: This consists of constant altitude (power setting/torque), airspeed, heading (adjusted with cyclic), and attitude is level providing the attitude indicator is adjusted correctly. Precise straight and level flight is possible in most weather conditions (IMC) if suitably configured with a means of stabilization.

When an instrument indicates an adjustment is required to maintain desired performance, the pilot will determine the required amount from other instruments. Airspeed, torque and/or altimeter indicate the adjustment to be made in power or altitude.

Corrections to changes in attitude should be made as soon as noticed. Then instead of fixating on that particular instrument to note the effect, the cross-check is continued, finally returning to the original instrument. This way the entire panel reflects the effect of the adjustment.

Any deviation from the desired heading will be evident on the heading indicator. Immediate and smooth application of cyclic control is initiated to return to the desired heading. Small heading excursions when promptly corrected maintain good attitude control.

When the correction is made, cross-check with the other performance instruments to verify the correction.

During straight and level flight power is used to adjust minor variations of altitude if the desired altitude cannot be maintained by varying pitch attitude without exceeding ± 10 knots of airspeed.

DESCENTS

- a/ Descents can be entered from essentially most normal flight configurations. The *power-attitude-trim (PAT)* technique is employed. Power/torque is reduced to a setting which results in the desired rate-of-descent. Attitude is initiated by cyclic and co-ordinated flight maintained by pedal trim adjustments.

Once established at a constant rate-of-descent, fine adjustments are made by collective pitch (power) changes. Prior to levelling off at the desired altitude, power is applied to check the downward movement through the desired altitude. A lead of



FIG. 5-4 • GOING BACK TO SHORE



approximately 10% of the vertical rate-of-descent is normally required, i.e. 50' for 500 fpm.

- b/ At the appropriate level-off altitude the power requirement for level cruise is used and a cross-check is started to re-establish level flight.

URNS: To find the angle of bank required to achieve a standard rate turn, figure about 15 percent of TAS. The number of degrees to be turned governs the amount of bank to be used. A change in heading of 20 degrees or more requires a *standard rate turn* (3 degrees per second) and is shown as a 2-needle deflection on the 4-minute turn-and-slip indicator. For changes of less than 20 degrees, one-half standard rate is sufficient and is shown as a 1-needle deflection.

LEVEL TURNS: To enter a turn, a movement of the cyclic control is applied in the direction of the desired turn. The initial bank is started with reference to the attitude indicator. When the desired angle of bank and rate of turn have been attained, control pressure should be relaxed to prevent overbank. To resume straight-and-level flight, co-ordinated movement of the cyclic control is applied in a direction opposite to the established turn. The rate of roll-out should be the same as the rate of roll-in.

URNS TO HEADINGS: A turn to a heading consists of a level turn to a specific heading as read from the heading indicator. Turns to specified headings should be made in the shortest direction. The turn is entered and maintained as described in the level turn manoeuvre. Since the helicopter will continue to turn as long as the bank is held, the roll-out must be started before reaching the desired heading. The amount of lead used to roll-out on a desired heading should be equal to one-half the angle of bank. The roll-out on a heading is performed in the same manner as the roll-out of the level turn.

STEEP TURNS: Any turn greater than standard rate is considered a steep turn. A steep turn is seldom necessary or advisable in IMC, but it is a good test of the individual's ability to react quickly and smoothly to changes in aircraft

attitude. The techniques of entry and recovery are the same as for any turn manoeuvre. Rate of turn and attitude are maintained with cyclic control; airspeed and altitude are maintained with power.

TIMED TURNS: The techniques of entry and control of the timed turn are the same as for the level turn. The position of the second hand of the clock must be noted when the turn is started. For ease in timing, start the time when the second hand passes the 3-, 6-, 9-, or 12-o'clock position. The standard rate of turn must be maintained until the predetermined time has elapsed, then the roll-out is started. The rate of roll-out is the same as the rate of roll-in.



FIG. 5-5 • FAILED ATTITUDE INDICATOR

5.6 HELICOPTER APPROACHES (ONSHORE/OFFSHORE)

The manual for designing instrument approaches (TP 308) now defines specific criteria used for helicopter instrument approaches.

Helicopter only approaches are identified by the term "*Copter*", the type of facility producing the final approach course guidance and a numerical identification of the final approach course.

The criteria for Copter approaches are based on the premise that helicopters have special manoeuvring characteristics and fit into approach *Category A* (90 kts or less) regardless of helicopter weight or speed. These approaches are generally shorter in length and the descent gradient on approach can be steeper than conventional approaches. Transport Canada approves company instrument approaches for helicopters operating to and from offshore platforms and ships.

Helicopters can also fly the instrument approaches published in *Canada Air Pilot (CAP)*.

5.7 EMERGENCIES

A. PARTIAL PANEL

1/ **FAILED ATTITUDE INDICATOR:** When the attitude indicator fails, primary pitch and roll references are lost. The vertical speed indicator is too sensitive for indicating pitch changes and should be used as a trend instrument only. The primary control instruments for indicating pitch are the airspeed indicator and the altimeter. The turn needle becomes the heading indicator (performance instrument) as required. When correcting the pitch attitude the helicopter is approximately level when VSI and/or airspeed indicator reverse direction of movement.

IFR
FLARE TO + 10° ON A.D.I.

FLARE HEIGHTS
S332/SK61 - 200' RAD. ALT.
BH12/S76 - 150' RAD. ALT

NOTE:
These altitudes, airspeeds and flare pitch altitudes are examples only. For specific information, consult the applicable manufacturers Aircraft Flight Manual

* **DESCENT CHECK**
S332/SK61 - 100' RAD. ALT.
BH12/S76 - 75' RAD. ALT.

* At this point the slight collective up motion is a reminder to check descent as Rad. Alt. descends through 40'.

AUTOROTATION PROCEDURE

REDUCE SPEED TO 70 KTS
TURN INTO WIND - MAINTAIN HEADING & AIRSPEED

NIGHT
NIGHT-LIGHTS ON AT 500' IF FREE OF CLOUD

OVER WATER
DEPLOY FLOATATION AT FLARE

2/ **FAILED HEADING INDICATOR:** If the gyro compasses (free or slaved) fail in flight all reference to heading must be accomplished using the standby compass. Use of standard rate turns and timed turns partial panel are used to achieve heading changes. An instrument approach under these conditions requires advance planning and a straight-in approach employing minimum turns is recommended. Any combination of failures of auto-pilots, attitude or heading indicators is a serious emergency and requires constant

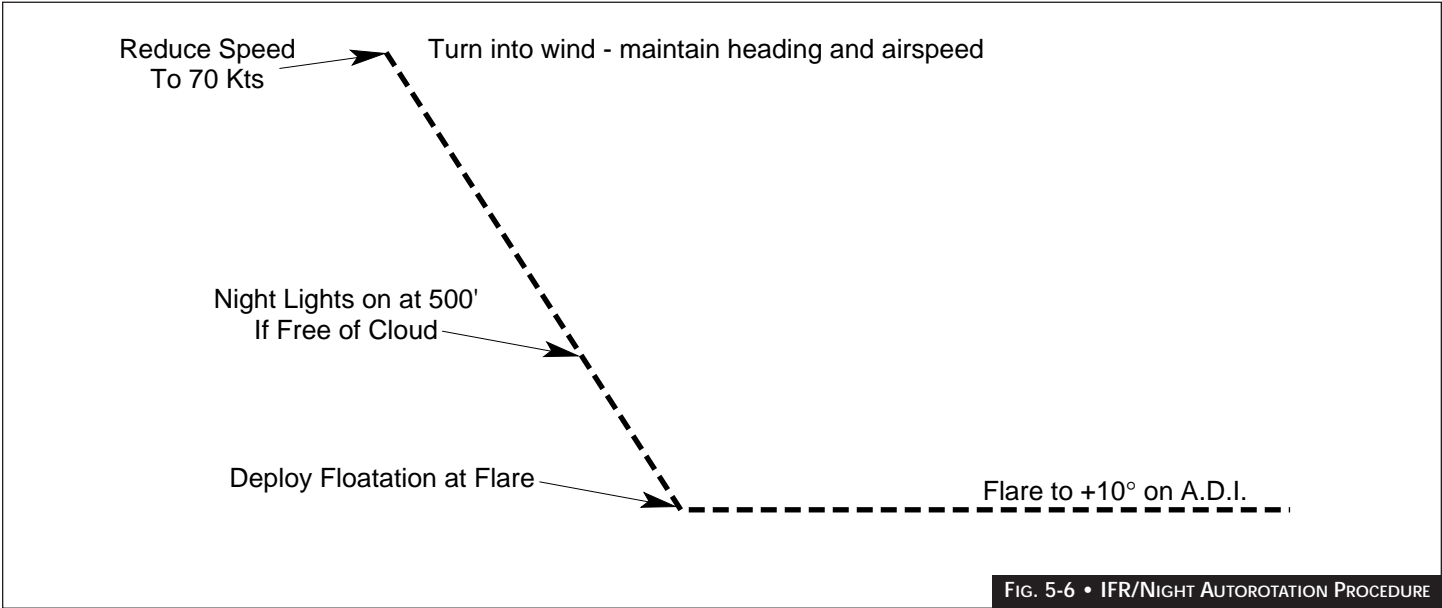

FIG. 5-6 • IFR/NIGHT AUTOROTATION PROCEDURE



monitoring by the second pilot. Maintaining co-ordinated instrument flight with malfunctioning flight instruments and without an auto-pilot is a critical emergency.

B. AUTOROTATION

If an autorotation is required the pilot should use the appropriate airspeeds dependent upon the manufacturer's recommended procedures. It is imperative that to conserve rotor rpm, the *collective be lowered immediately* and smoothly and the control and performance instruments be closely monitored. Particular attention should be given to keeping the helicopter in co-ordinated flight.

Generally use an airspeed that results in a minimum rate of descent commensurate with safety for the particular type. Turns are accomplished using the same basic techniques as in powered flight. Rotor rpm tends to *increase during turns* in autorotation and limiting the overspeed tendency of the rotor should be included in the cross-check. Knowing the approximate ceiling will assist in determining when to include outside references. Crew cooperation and adherence to standard operating procedures are prerequisites to a successful autorotation under IMC. Final descent to touchdown profiles should be developed and committed to memory. The procedure shown in Fig. 5-6 is an example only.

C. UNUSUAL ATTITUDES

Recoveries from unusual attitudes are unique due to helicopter aerodynamics in conjunction with application of the control and performance concept to helicopter flight. Improper recovery techniques can result in loss of control and structural damage.

1/ *TO RECOVER* from an unusual attitude, the pilot corrects the pitch and bank attitude, adjusts power, and trims the aircraft as necessary. All components are changed almost simultaneously with little lead of one over the other. In other words, if the aircraft is in a steep climbing turn or descending turn, bank, pitch, and power are corrected simultaneously. The *bank attitude* is corrected with reference to the

turn-and-bank indicator, or attitude indicator if available. *Pitch attitude* is corrected with reference to the altimeter, airspeed indicator, vertical speed indicator, and the attitude indicator, if available. *Power* is adjusted with reference to the power control instruments and the airspeed indicator.

- 2/ *IF DIVING*, consider altitude, acceleration limitations and the possibility of blade stall; as altitude permits, *avoid rolling pullouts*. Recovery action should be initiated by rolling the helicopter level referencing the turn needle, cross-checking the attitude indicator and heading indicator. Adjust power as necessary to prevent exceeding VNE and resume normal cruising flight at the appropriate power setting.
- 3/ *IF CLIMBING*, consider pitch attitude and airspeed. When the pitch attitude is not extreme (10° or less from level flight), smoothly lower the pitch attitude back to the level flight reference on the attitude indicator. Level the aircraft with reference to the turn needle and heading indicator, then resume a normal cross-check adjusting power as required. For *extreme nose high attitudes* (above 10°), bank the helicopter in the shorter direction toward the nearest 30° bank index. The amount of bank used should be commensurate with the pitch attitude, but *do not exceed 30° of bank* when making the recovery. Pitch the nose toward the horizon line on the attitude indicator and when the nose is on the horizon, ensure that the helicopter is level and adjust the power as necessary throughout the recovery process. Arresting movement and noting reversal of airspeed indicator and VSI will assist in determining the level attitude.
- 4/ *THE DISPLACEMENT OF CONTROLS* used in recoveries from unusual attitudes should not be greater than those for normal flight. Thus care must be taken in making adjustments as straight-and-level flight is approached. The instruments must be observed closely to avoid overcontrolling.

NOTES:

1. *High nose-up attitudes and high power requirements are particularly dangerous.*

*Setting power (collective) to a mid-range value will assist in the recovery process. Rapid reduction of the collective in a nose high attitude poses critical control problems as the rotor is now unloaded and a delay is experienced from a control input. The tendency is to provide an additional input and the result could be that the flapping angle is exceeded allowing the rotor head to contact the mast (mast-bumping) or the main rotor blades to contact the fuselage with catastrophic consequences. **A low airspeed and/or pitch combination is a potentially dangerous manoeuvre and should be avoided.***

2. *In helicopters when encountering an unusual attitude as a result of blade stall, collective (power) must be reduced before applying attitude corrections if the helicopter is in a nose high unusual attitude. This will aid in eliminating the possibility of aggravating the blade stall condition. To avoid blade stall in a diving unusual attitude, reduce the collective (power) and bank attitude before initiating a pitch change. **Most importantly, in all cases avoid abnormal positive or negative G loading which could lead to other unusual attitudes, structural damage or failure.***

D. INADVERTENT IMC (HELICOPTER NOT SUITABLY EQUIPPED)

Accidental entry into IMC for helicopters not certified for IFR flight must be *avoided at all costs*. Flight into IMC for these helicopters requires immediate controlled action. ***Inadvertent IMC for a pilot not IFR qualified flying a helicopter without the appropriate instruments is a recipe for disaster.***

Control of the helicopter and transition onto instruments is vital to the safety of the flight. Confirm the attitude of the helicopter and ensure that it is not in an unusual attitude. Reference to the control and performance instruments for pitch, roll and yaw information is essential.

As soon as able after the aircraft is in a stable flight condition action must be commenced to *transition to VMC*. This may include a 180° turn, a climb (if the cloud tops and obstructions are known for the area) performance and

altitude permitting, or a descent to below the cloud base can be accomplished providing the pilot knows exactly the weather conditions and whether a safety margin exists between the cloud base and the ground, water or obstructions. Alternatively the pilot may attempt to contact ATC for a clearance and be radar vectored to VMC.

For the VFR pilot the time honoured *180° turn* may be the safest and most expedient procedure and should be accomplished prior to entering the cloud or whiteout condition. If a steady flight condition exists prior to entry into IMC, the time and heading are noted. On a cardinal point, 12, 3, 6 or 9 o'clock a standard rate-one turn is commenced. At 3°/sec it takes one minute to complete a 180° turn. The pilot then flies the reciprocal heading that was flown into IMC, and at the end of the required time should have exited into VMC. This procedure should not be commenced if the helicopter has been forced into a *low altitude/low airspeed scenario in IMC*, as a 180° turn made by reference to the instruments in this scenario *almost guarantees an accident*. It cannot be over-emphasized that *VFR helicopter pilots must avoid cloud penetration at all times*.

The above procedures are designed to assist the pilot who is flying a helicopter without IFR instrumentation. ***Situations that place the VFR helicopter pilot in IMC must always be avoided.***



P
A
R
T
S
I
X

IFR TRAINING PROGRAMME

- 6.1 INTRODUCTION
- 6.2 GROUND TRAINING
- 6.3 SYNTHETIC FLIGHT TRAINING
- 6.4 FLIGHT TRAINING



6.1 INTRODUCTION

6.1.1 GENERAL

The following outline of *ground school*, *simulator* and *flight training* is presented as a sample syllabus for training in *preparation for the instrument rating*. Prepared with the assistance of flight training organizations in Canada, it represents the *recommended training* for a candidate starting training with limited aviation experience. The resources available to the flight training unit, qualifications of instructional staff as well as the capability of the student should determine the nature of the training program. For example, if an approved ground procedures trainer is not available, the flight training air time may have to be extended to provide for complete training in a particular subject area.

6.1.2 ADVICE TO PERSONS CONDUCTING TRAINING

Persons conducting instrument rating instruction or planning a course syllabus should consider and include all the necessary knowledge and skills for the student to use the instrument rating, not just to pass the written examination and flight test. The broad area of *human factors* should not be neglected. *Aviation physiology* related to instrument flight, *decision making* and *judgement training* should be integrated into both the ground school and flight training. The *Aeroplane Flight Instructor Guide* (TP975) and Federal Aviation Administration *Instrument Flying Handbook* (AC61-27C) are both good references for the instrument rating instructor.

Any instrument training program should allow sufficient *calendar time* for the student to assimilate the material involved in preparing for the instrument rating. A short intensive course of ground or flight training may be successful in gaining a pass in the written exam or flight test, but may leave the student inadequately prepared to handle an IFR flight in demanding weather conditions. A well integrated flight and ground school curriculum which allows for informal

study and an opportunity for the student to monitor other IFR pilots in flight will aid the learning process.

Even though the minimum experience requirements for the instrument rating may be met without actual cloud time or without any flights on an IFR flight plan, this is not recommended. Flight training involving *actual IFR* flights with the student handling progressively more decision making and ATC communications is *strongly recommended*. Opportunities for *actual instrument flight time* (in cloud) should be used by the instructor to build student confidence and to provide for learning reinforcement.

For the purposes of scheduling during the initial flight training, it is recommended that lessons be limited to 1.5 hours as student receptivity drops sharply beyond this time frame. *Mutual flying* with instrument rating students can be used to good advantage by the flight training unit when each student has reached a satisfactory level of knowledge for the exercises to be practised. This is particularly beneficial for the student acting as safety pilot.

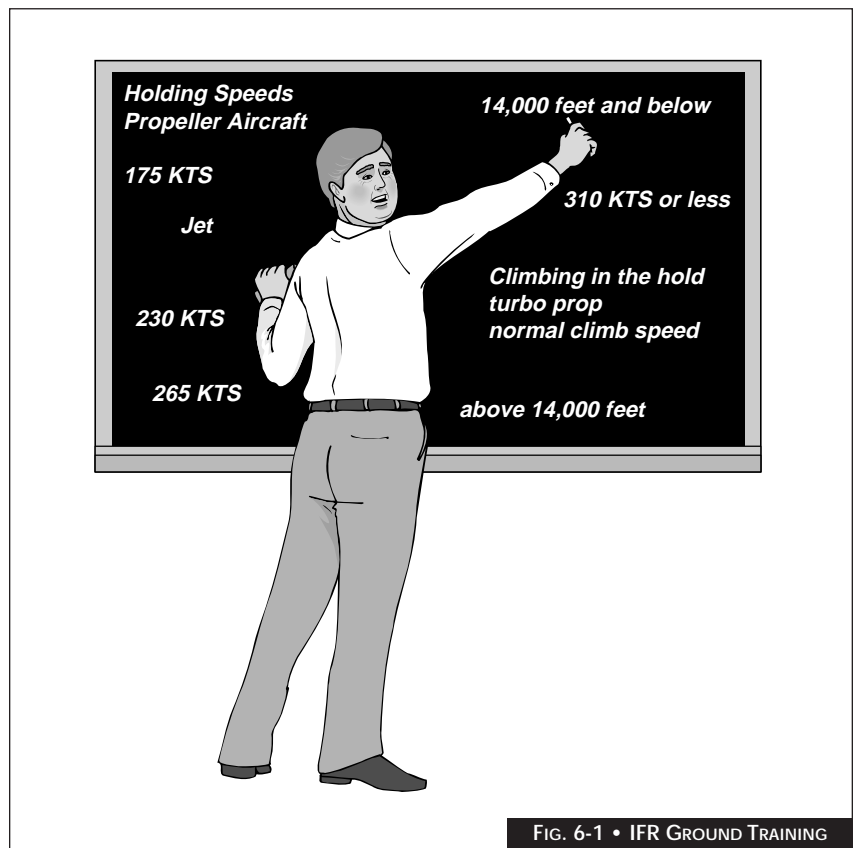

FIG. 6-1 • IFR GROUND TRAINING

6.1.3
COMPLETION OF TRAINING

On completion of training, the completion and signature of Part C of the Application for Endorsement of a Rating (Form 26-0083, see Fig. 6-2) by a person who is qualified in accordance with the *Personnel Licensing Handbook*, Vol 1, Part II, Chapter 1, certifies that the candidate has been adequately trained and has reached a sufficient level of competence to undertake a flight test. Transport Canada monitors the flight test record of qualified persons making such recommendations.

6.2 GROUND TRAINING

6.2.1
COURSE OUTLINE

LESSON PLAN	TIME	SUBJECT
General 1	1.5 hours	Introduction
General 2	1.5 hours	VFR Review
IFR 1	1.5 hours	Flight Planning General
IFR 2	1.5 hours	Departures
IFR 3	1.5 hours	En route
IFR 4	1.5 hours	Arrivals
IFR 5	1.5 hours	Approaches
IFR 6	1.5 hours	Emergencies
Instruments 1	3.0 hours	Flight Instruments
Instruments 2	3.0 hours	Navigation Instruments & Equipment
Instruments 3	1.5 hours	Compasses
Instruments 4	1.5 hours	Other Navigation Equipment in Use

Meteorology 2	1.5 hours	Air Masses
Meteorology 3	1.5 hours	Cold Fronts
Meteorology 4	1.5 hours	Warm Fronts
Meteorology 5	1.5 hours	Thunderstorms
Meteorology 6	1.5 hours	Icing, Turbulence, Fog
Meteorology 7	1.5 hours	Weather Charts
Meteorology 8	1.5 hours	Weather Reports
Meteorology 9	1.5 hours	Weather Planning
Meteorology 10	1.5 hours	Review & Discussion
Navigation 1	1.5 hours	Flight Planning IFR
Navigation 2	1.5 hours	Computer Problems
Navigation 3	1.5 hours	General Navigation Exercise
Navigation 4	3.0 hours	Cross Country Exercise (Flight Planning Only)
Practice Examination	3.0 hours	

6.2.2
INTRODUCTION 1.5 HOURS

- a. Objective of Course
- b. Air Traffic Control Services in Canada - History, Services Provided, Description of Ground, Tower, Terminal, Departure, Arrival, ACCs
- c. ICAO - History, Organization, Method of Disseminating Information, Compliance
- d. Definitions
- e. Characteristics of Canadian Airspace, Airways and Routes

PART C - RECOMMENDATION

I hereby certify that the applicant has completed the training and experience prescribed in the personnel licensing handbook relative to this application and is competent to hold _____ rating(s).

The applicant is recommended for a flight test. (Check here if a flight test is required)

 D M Y Print Name Signature Licence No. Organization
 Date

FIG. 6-2 • RECOMMENDATION FOR INITIAL INSTRUMENT FLIGHT TEST



6.2.3

VFR REVIEW

1.5 HOURS

- a. VFR - Weather Minima, Flight Planning, Pilot, Aircraft & Fuel Requirements, Communications
- b. SVFR - Weather Minima, Authority
- c. DVFR - General, ADIZ, Scatana Requirements & Compliance
- d. Cruising Altitudes
- e. Standard Pressure Region
- f. Sparsely Settled and Mountainous Regions

6.2.4

FLIGHT PLANNING GENERAL

1.5 HOURS

- a. Pilot, Aircraft and Weather Requirements for Operating under IFR conditions
- b. *C.A.P.*, LE, LO and HE Charts, *Canada Flight Supplement*, Terminal Charts
- c. Route Planning - IFR Preferred Routes
- d. Flight Logs
- e. Flight Plans
- f. NOTAMS
- g. To United States
- h. AIRMETS/SIGMETs
- i. Use of ICAO Flight Plan

6.2.5

DEPARTURES

1.5 HOURS

- a. ATIS
- b. Checks and Briefings
- c. Clearances - Clearance Limit
- d. Departures - SID
- e. Departures - NON SID
- f. Departures - Uncontrolled Airports
- g. Departure Procedure - Mountainous Regions
- h. Obstacle and Terrain Clearance

6.2.6

EN ROUTE

1.5 HOURS

- a. Radar & Non Radar
- b. MEA, MOCA, MRA, GASA, MSA
- c. Clearance Limits - Holding
- d. Altitude Changes - Canada and United States

- e. Position Reporting
- f. Intersections
- g. Turning Points
- h. Class F Advisory/Restricted Airspace

6.2.7

ARRIVAL

1.5 HOURS

- a. Clearances
- b. Profile Descents, Standard Terminal Arrivals (STAR)
- c. Terminal
- d. Controlled Airports, Uncontrolled Aerodromes
- e. Radar & Non Radar
- f. Airports with no Tower
- g. Holding
- h. Information Required by Pilot

6.2.8

APPROACHES

1.5 HOURS

- a. Clearances
- b. Approach Charts
- c. Approach and Runway Lighting
- d. Transitions
- e. Radar and Non Radar
- f. ILS and ILS/DME Approaches
- g. LOC (BC) Approaches
- h. NDB Approaches
- i. VOR Approaches
- j. DME ARCs
- k. RNAV Approaches (optional)
- l. Missed Approaches
- m. CAT II ILS (optional)

6.2.9

EMERGENCIES

1.5 HOURS

- a. Departure, En route, Arrival
- b. Communications Failure
- c. Navigation Equipment Failure
- d. Flight Instruments Failure
- e. System Failure
- f. Engine Failure
- g. 121.5
- h. Hijacking
- i. ELT

6.2.10

FLIGHT INSTRUMENTS

3.0 HOURS

- a. Attitude Indicator - Principles of Operation, Limitations, Failures
- b. Heading Indicator - Principles of Operation, Limitations, Precession, Failure
- c. Turn and Slip - Principles of Operation, Rates of Turn, Failures
- d. Turn Co-ordinator - Principles of Operation, Rates of Turn, Failures
- e. Vertical Speed Indicator - Principles of Operation, Limitations, Failure, IVSI
- f. Airspeed Indicator - Principles of Operation, Limitations, Failure, Pitot Heat, Mach
- g. Altimeter - Principles of Operations, Limitations, Failure, Types
- h. Flight Director Indicator - Principles of Operation, Limitations, Failures
- i. Horizontal Situation Indicator - Principles of Operation, Limitations, Failures

6.2.11

NAVIGATION INSTRUMENTS & EQUIPMENT

3.0 HOURS

- a. VOR & VOT - Principles of Operation, Limitations, Failure, Identification, Frequencies, Equipment Checks on VOT, Inherent Errors
- b. ADF - Principles of Operation, Limitations, Identification, Radio Stations, Power, Frequency Range, Fixed Card & RMI, Inherent Errors
- c. ILS - Principles of Operation, Limitations, Identification, Frequency Band, Components of System, Localizer Only, Track Guidance Localizer, Inherent Errors
- e. DME - Principles of Operation, Limitations, Identification, Use of TACAN DME
- e. TRANSPONDER - Principles of Operation, Limitations, Use, Altitude Reporting

6.2.12

COMPASSES

1.5 HOURS

- a. Magnetic - Principles of Operation
Compass Compass Errors - Variation, Deviation, Dip Tolerances and Unserviceabilities
Swinging - Frequency & Procedures
- b. Gyro Compass - Principles of Operations
Errors
Tolerances & Unserviceabilities
Swinging
Slaving

6.2.13

OTHER NAVIGATION EQUIPMENT IN USE

1.5 HOURS

- a. INS
- b. OMEGA, OMEGA/VLF
- c. LORAN C
- d. GPS - Use for En Route and Approaches
- e. RNAV
- f. TACAN
- g. MLS

6.2.14

METEOROLOGY

1.5 HOURS

INTRODUCTION

- a. History of Canadian Weather Services
- b. Temperature
- c. Pressure
- d. Moisture
- e. Clouds
- f. Precipitation
- g. Visibility
- h. Wind

6.2.15

AIR MASSES

1.5 HOURS

- a. Description
- b. Types of Air Masses Normal to Canada
- c. Characteristics
- d. Stability & Moisture
- e. Modification
- f. Fronts
- g. Trowals/Troughs

6.2.16
COLD FRONTS

1.5 HOURS

- a. Description
- b. Factors Governing Frontal Weather
- c. Surface Winds
- d. Temperature
- e. Moisture
- f. Cloud & Precipitation
- g. Visibility
- h. Pressure
- i. Upper Cold Fronts

- b. Icing
 - Formation
 - Types
 - Airframe
 - Engine
 - Precautions
 - Flight Precautions/Regulations
- c. Fog
 - Types
 - Formation
 - Dissipation
- d. Clear Air Turbulence (CAT)
- e. Mountain Waves

6.2.17
WARM FRONTS

1.5 HOURS

- a. Description
- b. Factors Governing Frontal Weather
- c. Surface Winds
- d. Temperature
- e. Moisture
- f. Cloud & Precipitation
- g. Visibility
- h. Pressure
- i. Upper Warm Fronts

6.2.20
CHARTS

1.5 HOURS

- a. Upper Level
- b. Surface charts
- c. Symbols
- d. Frequency
- e. Specialty Charts

6.2.18
THUNDERSTORMS

1.5 HOURS

- a. Description
- b. Stages & Types
- c. Surface Weather
- d. Flight Weather
- e. Static
- f. Precautions in Vicinity
- g. Lightning Detection Systems and Weather Radar

6.2.21

WEATHER REPORTS/FORECASTS

1.5 HOURS

- a. Aviation Weather Forecasts
 - Frequency
 - Description
 - Information Available
- b. Aviation Weather Reports
 - Frequency
 - Description
 - Information Available
- c. Symbols

6.2.19
ICING, TURBULENCE, FOG

1.5 HOURS

- a. Turbulence
 - Mechanical
 - Thermal
 - Frontal
 - Wind Shear
 - Flight Precautions

6.2.22

WEATHER PLANNING

1.5 HOURS

- a. Information to Give FSS Weather Briefer
- b. Information to be Obtained from FSS or Computer Briefing
- c. Route Forecasts
- d. Altitude Planning
- e. Destination and Alternate Planning
- f. Cloud
- g. Turbulence
- h. Icing
- i. Winds/Jet Stream

6.2.23
REVIEW AND DISCUSSION **1.5 HOURS**

- a. General Review and Discussion
- b. Workshop Problems

6.2.24
FLIGHT PLANNING IFR **1.5 HOURS**

- a. Weather & NOTAMs
- b. Flight Log - Routing to Destination & Alternate
 - Altitudes, (MEA, MRA, MOCA, CRUISE ALTITUDE)
 - Track
 - Heading
 - Airspeed (IAS, CAS, EAS, TAS, MACH)
 - Reporting Points, Altitude Changes, Changeover Points
- c. Flight Plan - Completing
 - Filing
- d. Equipment - Pilot
 - Aircraft
 - Departure, En route, Arrival, Approach
- e. Block Times at Busy Airports
- f. IFR Preferred Routes
- g. Filing Into Prior Permission Airports
- h. Filing to United States

6.2.25
FLIGHT PLANNING COMPUTER PROBLEMS
1.5 HOURS

- a. Description
- b. Time, Speed, Distance
- c. Fuel
- d. Statute, Nautical Miles & Kilometres
- e. Airspeed & Altimeter Corrections
- f. Heading & Ground Speed
- g. Wind Direction & Speed
- h. Point of No Return (optional)
- i. Critical Point (optional)

NOTE:

Further time may be required in the use of the flight computer depending on the student's previous knowledge.

6.2.26
GENERAL NAVIGATION PROBLEMS **1.5 HOURS**

- a. Short X-Country with given winds, etc. for nav. purposes only

6.2.27
FLIGHT PLANNING EXERCISE **3.0 HOURS**

- a. Full X-Country using prepared weather forecasts, sequences and routings prevalent during the period of time laid down in the exercise

NOTE:

Common LE charts will have to be obtained when preparing this exercise. Outdated charts may be used for practice as long as they were all issued on the same date.

6.2.28
PRACTICE EXAM **3.0 HOURS**

This examination should be prepared by the school (preferably more than one being available) in the same format as the DOT Instrument Examination in order to provide students with a measure of their level of knowledge. Should a multiple choice type exam be prepared, care should be taken to provide an exam which will allow an in-depth probe of the students knowledge. Combination multiple choice and direct answer papers might provide a good yardstick.

6.3 SYNTHETIC FLIGHT TRAINING

Figures 6-3 and 6-5 show two synthetic flight trainers and advanced Level II trainers approved by Transport Canada.

TRAINING SYLLABUS

Recommended Minimum

TIME

6.3.1

BASIC INSTRUMENT REVIEW

2.0

- a. Use of Flight Instruments
- b. Recognition of Attitudes
- c. Straight and Level Flight
- d. Climbing
- e. Descending
- f. Turns (rate 1/2, rate 1, 30° and 45° of bank)
- g. Climbing Turns
- h. Descending Turns
- i. Co-ordinated Patterns
- j. Approach to Stall
- k. Recovery from Stall
- l. Recovery from Unusual Attitudes

NOTES:

1. Sequences to be completed using both partial (limited) and full instrument panel.
2. Allocated time should be used as basic instrument review and training familiarization. Actual time is dependent upon student exercise and progress.

6.3.2

AUTOMATIC DIRECTION FINDER (ADF/NDB)

4.0

- a. Orientation
- b. Tracking: To-From;
- c. Intercepting Pre-determined Track: To-From;
- d. Determining Position
- e. Determining Time and Distance
- f. Procedure Turn



FIG. 6-3 • "LEVEL II PILOT TRAINER"

NOTE:

Sequences should be conducted using both the Radio Magnetic Indicator (RMI) (Rotating Compass Card) and the Fixed Card Indicator (Relative Bearing), subject to the trainer instrumentation.



FIG. 6-4 • "PILOT TRAINER EFIS DISPLAY"

6.3.3
VERY HIGH FREQUENCY
OMNIDIRECTIONAL RANGE (VOR) 4.0

- a. VOR Test Signal (VOT)
- b. Orientation
- c. Tracking: To; From;
- d. Intercepting Pre-determined Track: To; From;
- e. Determining Position
- f. Determine Time and Distance
- g. Procedure Turn

NOTE:

Sequences should be conducted using the Horizontal Situation Indicator (HSI), Radio Magnetic Indicator (RMI) and Track Indicator only, subject to the trainer instrumentation.

6.3.4
DISTANCE MEASURING EQUIPMENT (DME) 1.5

- a. Intercepting DME ARC
- b. Tracking DME ARC
- c. Intercepting Radial from DME ARC

NOTE:

Sequences should be conducted using the Radio Magnetic Indicator (RMI) and Track Indicator only, subject to the trainer instrumentation.

6.3.5
HOLDING 3.0

- a. Principles of Entry to and Flying the Standard and Non-standard Holding Pattern.
- b. Entry to and Holding Pattern at:
 - 1. NDB
 - 2. VOR
 - 3. Intersection
 - 4. DME FIX

NOTES:

- 1. *Sequences should be conducted using the Horizontal Situation Indicator (HSI), Radio Magnetic Indicator (RMI) and Track Indicator only, subject to the trainer instrumentation.*
- 2. *Candidates should have prior knowledge of wind velocity gained from forecast W/V and/or tracking to holding fix.*

6.3.6
APPROACHES AND MISSED APPROACHES 6.0

- a. Full Published Approach:
 - 1. NDB
 - 2. VOR
 - 3. ILS Front Course
 - 4. LOC Only
 - 5. LOC Back Course
 - 6. PAR (if available)
 - 7. RNAV (if available and approved)
- b. Approach After Holding on an Approach Fix:
 - 1. NDB
 - 2. VOR
 - 3. ILS
 - 4. LOC Back course
- c. Transition to Straight in Approach:
 - 1. Off Radar Vector
 - 2. Off Published Transition
- d. Circling Approach

NOTES:

- 1. *Sequences should be conducted using different available trainer equipment (eg Horizontal Situation Indicator (HSI), Radio Magnetic Indicator (RMI), Fixed Card Bearing Indicator, etc.*
- 2. *Circling may not be possible due to the lack of trainer visual presentation.*
- 3. *Candidates should be exposed to both the landing and the missed approach following approaches to the missed approach point*

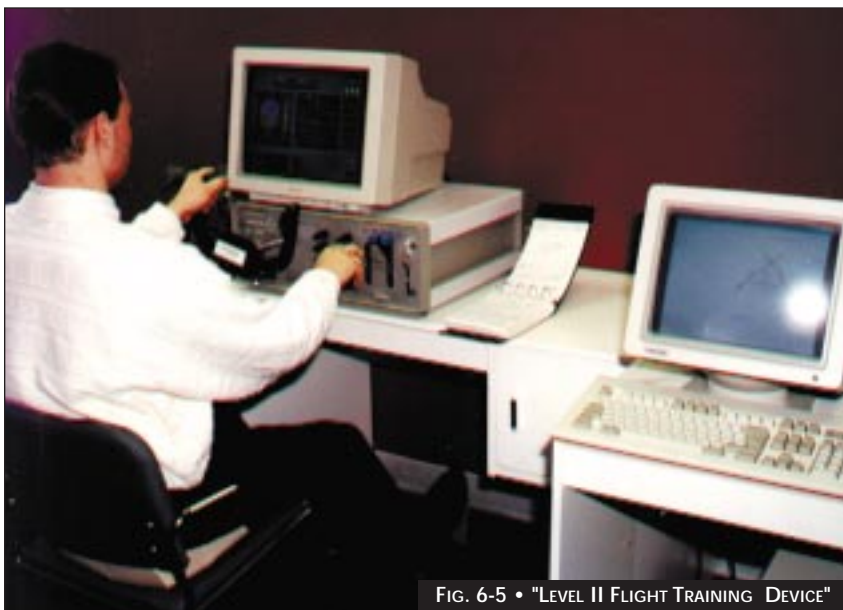

FIG. 6-5 • "LEVEL II FLIGHT TRAINING DEVICE"

(MAP) at DH or MDA, subject to trainer capabilities.

6.3.7
AIR TRAFFIC SERVICES (ATS)
CLEARANCES/PROCEDURES 1.0

- a. Departure:
 - 1. Without Radar Services
 - 2. With Radar Services
 - 3. Standard Instrument Departure (SID)
- b. Arrival:
 - 1. Without Radar Services
 - 2. With Radar Services
 - 3. Standard Terminal Arrival (STAR)

NOTE:

Departure and arrival sequences should be completed in conjunction with other related sequences.

6.3.8
IFR CROSS COUNTRY 3.0

- a. Preparation of Flight Log
- b. Preparation of Flight Plan
- c. Departure
- d. En route
- e. Holding
- f. Transition
- g. Approach
- h. Missed Approach
- i. Diversion to Alternate
- j. Approach
- k. Emergencies

6.4

FLIGHT TRAINING INSTRUMENT RATING TRAINING SYLLABUS

GENERAL NOTES

1. *This flight training IFR syllabus is based upon the student successfully completing the related training sequence in a synthetic flight trainer prior to undertaking the applicable flight training sequence.*
2. *When the synthetic flight trainer is not equipped to provide training in recommended sequences, or a trainer is not available, the recommended minimum flight times can be increased accordingly to meet the student's training requirements.*
3. *The recommended minimum times refer to "Instrument Flight Time" as defined in the Personnel Licensing Handbook Volume 1 Flight Crew Part I Section 8, that is: "Flight time during which a pilot is controlling an aircraft by sole reference to the flight instruments and without external reference points".*
4. *It is recognized that not all training aircraft will be equipped to carry out all recommended training sequences. For*

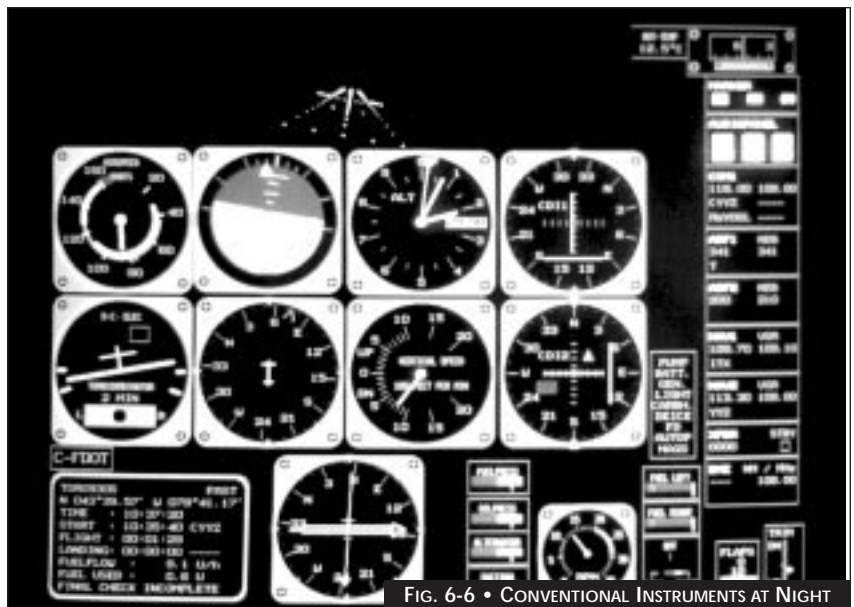

FIG. 6-6 • CONVENTIONAL INSTRUMENTS AT NIGHT

example, the aircraft may not be equipped with an RMI to provide ADF and VOR training using that equipment, or DME to permit training in intercepting and flying DME ARCS.

Magnetic Indicator (RMI) (Rotating Compass Card).

RECOMMENDED MINIMUM TIME

6.4.1 INSTRUMENT FLYING 6.0

- a. Use of Flight Instruments
- b. Recognition of Attitudes
- c. Straight and Level Flight
- d. Climbing
- e. Descending
- f. Turns
- g. Climbing Turns
- h. Descending Turns
- i. Co-ordinated Patterns
- j. Approach to Stall
- k. Recovery from Unusual Attitudes

NOTES:

1. Sequences to be carried out both partial (limited) and full instrument panel.
2. Recommended minimum time of 6.0 hours should be regarded as time for review purposes and to familiarize student with instrument flying on the aircraft type. Actual time will be dependent upon individual student's past instrument flying training, experience and progress.

6.4.2 AUTOMATIC DIRECTION FINDER (ADF/NDB) 4.0

- a. Orientation
- b. Tracking: To-From;
- c. Intercepting Pre-determined Track: To-From;
- d. Determining Position
- e. Determining Time and Distance
- f. Procedure Turn

NOTE:

Subject to aircraft equipment, sequences to be carried out using the Fixed Card Bearing Indicator (Relative Bearing) and the Radio

6.4.3 VERY HIGH FREQUENCY OMNIDIRECTIONAL RANGE (VOR) 4.0

- a. VOR Test Facility (VOT)
- b. Orientation
- c. Tracking: To-From;
- d. Intercepting Pre-determined Radials: To-From;
- e. Determining Position
- f. Determining Time and Distance
- g. Procedure Turn

NOTE:

Subject to aircraft instrumentation sequences to be carried out with the Horizontal Situation Indicator (HSI), Radio Magnetic Indicator (RMI) and Track Indicator only.

6.4.4 DISTANCE MEASURING EQUIPMENT (DME) 1.5

- a. Intercepting DME ARC
- b. Tracking DME ARC
- c. Intercepting Radial from DME ARC

NOTE:

Sequences should be conducted using the RMI and Track Indicator only, subject to aircraft instrumentation.

6.4.5 HOLDING 2.0

- a. Principles of Entry to and Flying a Standard and Non-standard Holding Pattern
- b. Entry to and Holding Pattern at:
 - 1. NDB
 - 2. VOR
 - 3. Intersection
 - 4. DME FIX

NOTES:

1. Sequences should be conducted using the Horizontal Situation Indicator (HSI), Radio Magnetic Indicator (RMI) and Track Indicator only, subject to aircraft instrumentation.

2. *Students should always have prior knowledge of wind velocity from forecast weather and/or prior tracking to holding fix.*

sequences be carried out in conjunction with other related sequences.

6.4.6 APPROACHES AND MISSED APPROACHES 7.0

- a. Full Published Approach:
1. NDB
 2. VOR
 3. ILS
 4. LOC
 5. LOC Back Course
 6. PAR (if available)
 7. RNAV (if applicable and approved)
- b. Approach After Holding on an Approach Facility:
1. NDB
 2. VOR
 3. ILS
 4. LOC Back Course
- c. Transition to Straight-in Approach:
1. From Radar Vector
 2. From Published Transition
- d. Circling Approach

NOTES:

1. *Sequences should be conducted using different available aircraft equipment (eg) Horizontal Situation Indicator (HSI), Radio Magnetic Indicator (RMI), Fixed Card Bearing Indicator etc.*
2. *Students should be exposed to landings and missed approaches from the missed approach point (MAP) at DH or MDA.*

6.4.7 AIR TRAFFIC SERVICES (ATS) CLEARANCES/PROCEDURES 1.0

- a. Departure:
1. Without Radar Services
 2. With Radar Services
 3. Standard Instrument Departure (SID)
- b. Arrival:
1. Without Radar Services
 2. With Radar Services
 3. Standard Terminal Arrival (STAR)

NOTE:

It is recommended that departure and arrival

6.4.8 IFR CROSS COUNTRY 1.5

- a. Meteorological Briefing
- b. Preparation of Flight Log
- c. Preparation of Flight Plan
- d. Computation of Fuel Requirements
- e. Departure
- f. En route
- g. Holding
- h. Transition and Approach
- i. Missed Approach
- j. Diversion to Alternate
- k. Approach
- l. Emergencies

GENERAL NOTES

NOTES:

1. *The IFR cross country flight should be conducted with the student handling radio contact with ATC.*
2. *Student should be given the opportunity to fly as much actual cloud time as possible during training.*
3. *Emergency procedures such as failures of radio navigation and approach aids; communication facilities; and, other aircraft equipment including engine out procedures are to be interjected into the training sequences at appropriate times.*
4. *The minimum experience requirement to attain an instrument rating is stated in the Personnel Licensing Handbook, Volume 1.*

APPENDICES

APPENDICES

<i>APPENDIX 1</i>	DEFINITIONS
<i>APPENDIX 2</i>	ABBREVIATIONS
<i>APPENDIX 3</i>	RULES OF THUMB
<i>APPENDIX 4</i>	REFERENCES FOR INSTRUMENT FLYING



APPENDIX 1: DEFINITIONS

The following definitions relate to IFR flight. Additional definitions are available in *AIP Canada GEN*.

ACCELERATE/STOP DISTANCE AVAILABLE (ASDA)

The length of the take-off run available plus length of the stopway, if provided.

AIRBORNE COLLISION AVOIDANCE SYSTEMS (ACAS)

An aircraft system based on secondary surveillance radar (SSR) transponder signals which operates independently of ground-based equipment to provide advice to the pilot on potential conflicting aircraft that are equipped with SSR transponders.

AREA NAVIGATION (RNAV)

A method of navigation which permits aircraft operation on any desired flight path within the coverage of station-referenced navigation aids or within the limits of the capability of self-contained aids, or a combination of these.

AERONAUTICAL INFORMATION PUBLICATION (AIP)

A publication issued by or with the authority of a State and containing aeronautical information of a lasting character essential to air navigation.

AIRPORT AND AIRWAYS SURVEILLANCE RADAR (AASR)

A medium range radar designed for both airway and airport surveillance applications.

AIRPORT SURVEILLANCE RADAR (ASR)

Relatively short range radar intended primarily for surveillance of airport and terminal areas.

AIR TRAFFIC CONTROL CLEARANCE

Means authorization by an air traffic control unit for an aircraft to proceed within controlled airspace under specified conditions.

AIR TRAFFIC CONTROL INSTRUCTION

Means a directive issued by an air traffic control unit for air traffic control purposes.

ALTERNATE AIRPORT

Means an aerodrome specified in a flight plan to which a flight may proceed when a landing at the intended destination becomes inadvisable.

BEARING

The horizontal angle at a given point, measured clockwise from a specific reference datum, to a second point. Bearings are expressed at True, Magnetic, Relative, Grid, etc., according to the reference datum used.

CATEGORY I MINIMA

The minima for a Category I precision approach as set out in the *Canada Air Pilot*, the operations manual of an operator or as approved by a direction of the Minister in writing for a specific operator.

CIRCLING PROCEDURE	The visual manoeuvring required, after completing an instrument approach, to bring an aircraft into position for a landing on a runway which is not suitably located for a straight-in approach.
CLEARANCE LIMIT	The point to which an aircraft is granted an ATC clearance.
CLEARWAY	A defined rectangular area on the ground or water under the control of the appropriate authority, selected or prepared as a suitable area over which an aeroplane may make a portion of its initial climb to a specified height.
CODE (SSR code)	The number assigned to a particular multiple pulse reply signal transmitted by a transponder.
COMPULSORY REPORTING POINT	A reporting point designated by the Minister or specified as such by an ATC unit.
CONTACT APPROACH	An approach wherein an aircraft on an IFR flight plan, having an air traffic control authorization, operating clear of clouds with at least 1 mile flight visibility and a reasonable expectation of continuing to the destination airport in those conditions, may deviate from the instrument approach and proceed to the destination airport by visual reference to the surface of the earth.
CONTROL AREA	Means a controlled airspace extending upwards vertically from a specified height above the surface of the earth and designated as such in the <i>Designated Airspace Handbook</i> .
CONTROL AREA EXTENSION	Controlled airspace of defined dimensions within the Low Level Airspace extending upwards from 2200 ft. above the surface of the earth unless otherwise specified.
CONTROLLED AIRSPACE	Means an airspace of defined dimensions within which air traffic control service is provided.
DECISION HEIGHT (DH)	A specified height at which a missed approach must be initiated during a precision approach if the required visual reference to continue the approach to land has not been established.
DESIGNATED INTERSECTION	A point on the surface of the earth over which two or more designated position lines intersect. The position lines may be magnetic bearings from NDBs, radials from VHF/UHF aids, centre lines of designated airways, air routes, localizers and DME distances.
DISTANCE MEASURING EQUIPMENT (DME)	Equipment, airborne and ground, used to measure, in nautical miles, the slant range distance from a DME NAVAID.
DME ARC	A track, indicated as a constant DME distance, around a navigation facility which provides distance information.

EXPECTED APPROACH TIME (EAT)	The time at which ATC expects that an arriving aircraft, following a delay, will leave the holding point to complete its approach for a landing.
EXPECTED FURTHER CLEARANCE TIME (EFC)	The time at which it is expected that further clearance will be issued to an aircraft.
FAN MARKER BEACON	A type of radio beacon, the emissions of which radiate in a vertical fan-shaped pattern.
FINAL APPROACH	That segment of an instrument approach between the final approach fix or point and the runway, airport or missed approach point, whichever is encountered last, wherein alignment and descent for landing are accomplished.
FINAL APPROACH FIX (FAF)	A fix which indicates the commencement of the final approach segment of an instrument approach.
FINAL APPROACH COURSE FIX (FACF)	A fix which lies on the fix approach course prior to glidepath interception approximately 8 miles from the threshold of the runway and is used by Flight Management Systems of modern aircraft.
FLIGHT INFORMATION REGION (FIR)	Means an airspace of defined dimensions extending upwards from the earth within which flight information service and alerting service is provided.
FLIGHT LEVEL	An altitude expressed in hundreds of feet indicated on an altimeter set at 29.92 inches of mercury or 1013.2 millibars.
FLIGHT SERVICE STATION (FSS)	An aeronautical facility providing mobile and fixed communications, flight information, search and rescue alerting, and weather services to pilots and other users.
GLIDE PATH	A descent profile which is electronically determined for vertical guidance during a final approach.
GLIDE PATH ANGLE	The angle of the glide path measured in degrees above the horizontal plane.
HEIGHT ABOVE AERODROME (HAA)	The height in feet of the MDA above the aerodrome elevation.
HEIGHT ABOVE TOUCHDOWN	The height in feet of the DH or MDA above the touchdown zone elevation.
HIGH LEVEL AIR ROUTE	In the High Level Airspace, a prescribed track between specified radio aids to navigation, along which air traffic control service is not provided.
HIGH LEVEL AIRSPACE	All airspace that is within the Canadian domestic airspace at or above 18,000 feet ASL.

HIGH LEVEL AIRWAY	In controlled High Level Airspace, a prescribed track between specified radio aids to navigation, along which air traffic control service is provided.
HOLDING PROCEDURE	A predetermined manoeuvre which keeps an aircraft within a specified airspace while awaiting further clearance.
INITIAL APPROACH	That segment of an instrument approach between the initial approach fix or point and the intermediate fix or point wherein the aircraft departs the en route phase of the flight and manoeuvres to enter the intermediate segment.
INSTRUMENT APPROACH PROCEDURE	A series of predetermined manoeuvres for the orderly transfer of an aircraft under instrument flight conditions from the beginning of the initial approach to a landing or to a point from which a landing may be made visually.
INSTRUMENT LANDING SYSTEM (ILS)	An electronic system designed to provide an approach path for precise alignment and descent of aircraft consisting of a localizer, a glide path transmitter and may include marker beacons, DME or an NDB.
INSTRUMENT METEOROLOGICAL CONDITIONS (IMC)	Meteorological conditions, expressed in terms of visibility, distance from cloud, and ceiling, less than the minima prescribed in the <i>Air Regulations</i> for flight in VFR weather.
INTERMEDIATE APPROACH	That segment of an instrument approach between the intermediate fix or point and the final approach fix or point wherein the aircraft configuration, speed and positioning adjustments are made in preparation for the final approach.
LANDING DISTANCE AVAILABLE (LDA)	The length of runway which is declared available and suitable for the ground run of an aeroplane landing.
LOCALIZER	A VHF transmitter which provides a lateral alignment profile for front and back course ILS approaches to a runway.
LOW LEVEL AIR ROUTE	In the Low Level airspace, Class G Airspace extending upwards from the surface of the earth, within certain specified boundaries and within which air traffic control service is not provided.
LOW LEVEL AIRSPACE	All airspace within the Canadian Domestic Airspace below 18,000 feet ASL.
LOW LEVEL AIRWAY	Controlled Low Level Airspace, within certain specified boundaries extending upwards from 2,200 feet above the surface of the earth up to, but not including 18,000 ASL.

MANDATORY FREQUENCY (MF)

A regulated procedure that requires all pilots operating in the immediate vicinity of specified uncontrolled aerodromes to monitor, and transmit intentions, landing estimates and the appropriate approach, circuit, taxi and take-off reports as applicable.

MICROWAVE LANDING SYSTEM (MLS)

An instrument system operating in the microwave spectrum designed to provide precise lateral, longitude and vertical guidance to aircraft.

MINIMUM DESCENT ALTITUDE (MDA)

A specified altitude referenced to sea level for a non-precision approach below which descent must not be made until the required visual reference to continue the approach to land has been established.

MINIMUM EN ROUTE ALTITUDE (MEA)

The published altitude above sea level between specified fixes on airways or air routes which assures acceptable navigational signal coverage, and which meets the IFR obstruction clearance requirements.

MINIMUM NAVIGATION PERFORMANCE SPECIFICATIONS (MNPS)

Specified aircraft equipment requirements to ensure aircraft used to conduct flights within airspace that has been designated MNPS Airspace have a minimum navigation capability.

MINIMUM OBSTRUCTION CLEARANCE ALTITUDE (MOCA)

That altitude above sea level in effect between radio fixes on low level airways or air routes which meets the IFR obstruction clearance requirements for the route segment.

MINIMUM RECEPTION ALTITUDE (MRA)

Minimum reception altitude when applied to a specific VHF/UHF intersection, is the lowest altitude above sea level at which acceptable navigation signal coverage is received to determine the intersection.

MINIMUM SECTOR ALTITUDE (MSA)

The lowest altitude which will provide a minimum clearance of 1000 feet, under conditions of standard temperature and pressure, above all obstacles located in an area contained within a sector of a circle of 25 nautical miles radius centred on the specified facility.

MISSED APPROACH POINT (MAP)

That point on the final approach track which signifies the termination of the final approach and commencement of the missed approach segment.

MISSED APPROACH PROCEDURE

The procedure to be followed, if for any reason, after an instrument approach, a landing is not effected.

NORTH ATLANTIC (NAT) ORGANIZED TRACK SYSTEM

A system of tracks established and published, in accordance with ICAO Regional Supplementary Procedures, for use of aircraft operating over the North Atlantic during peak traffic periods.

NOTAM	A notice, containing information concerning the establishment, condition or change in any aeronautical facility, service, procedure or hazard, the timely knowledge of which is essential to personnel concerned with flight operations.
PRECISION APPROACH RADAR (PAR)	A high definition, short range radar used as an approach aid. This system provides the controller with altitude, azimuth and range information of high accuracy for the purpose of assisting the pilot in executing an approach and landing. This form of navigational assistance is termed "Precision Radar Approach".
PREFERRED RUNWAY	Where there is no active runway, the preferred runway is considered to be the most suitable operational runway taking into account such factors as: the runway most nearly aligned with the wind; noise abatement or other restrictions which prohibit the use of certain runway(s); ground traffic and runway conditions.
PROCEDURE TURN	A manoeuvre in which a turn is made away from a designated track followed by a turn in the opposite direction, both turns being executed so as to permit the aircraft to intercept and proceed along the reciprocal of the designated track.
RADIAL	A magnetic bearing from a VOR, TACAN, or VORTAC facility except for facilities in the Northern Domestic Airspace which may be oriented on True or Grid North.
REQUIRED VISUAL REFERENCE	In respect of an aircraft on an approach to a runway, means that section of the approach area of the runway or those visual aids that, when viewed by the pilot of the aircraft, enables the pilot to make an assessment of the aircraft position and the rate of change of position, relative to the nominal flight path.
RUNWAY VISUAL RANGE (RVR)	In respect of a runway, means the maximum horizontal distance, as measured by an automated visual landing distance system and reported by an air traffic control unit or a flight service station for the direction of takeoff or landing, at which the runway, or the lights or markers delineating it, can be seen from a point above its centre line at a height corresponding to the average eye level of pilots at touchdown.
SAFE ALTITUDE 100 NM	The lowest altitude which will provide a minimum clearance of 1000 feet in non-mountainous or 2,000 ft. in mountainous areas, under conditions of standard temperature and pressure, above all obstacles located in an area contained within a circle of 100 NM radius centred on a NAVAID or the geographic centre of the aerodrome.

**SECONDARY SURVEILLANCE
RADAR (SSR)**

A radar system that requires complementary aircraft equipment (transponder). The transponder generates a coded reply signal in response to transmissions from the ground station (interrogator). Since this system relies on a transponder-generated signal rather than a signal reflected from the aircraft, as in primary radar, it offers significant operational advantages such as increased range and positive indication.

SIMULATED APPROACH

An instrument approach procedure conducted in VFR weather conditions by an aircraft not on an IFR clearance.

STOPWAY

A defined rectangular area on the ground at the end of the runway in the direction of take-off prepared as a suitable area in which an aeroplane can be stopped in the case of an abandoned take-off.

SURVEILLANCE APPROACH

An instrument approach in which the final approach is conducted in accordance with directions issued by a controller referring to a surveillance radar display.

**TAKE-OFF DISTANCE
AVAILABLE (TODA)**

The length of the take-off run available plus the length of the clearway, if provided.

TAKE-OFF RUN AVAILABLE (TORA)

The length of runway declared available and suitable for the ground run of an aeroplane taking off.

TERMINAL CONTROL AREA

Controlled airspace of defined dimensions designated to serve arriving, departing and en route aircraft.

THRESHOLD

The beginning of that portion of the runway usable for landing.

**THRESHOLD CROSSING
HEIGHT (TCH)**

The height of the glide path above the runway threshold.

TOUCHDOWN ZONE (TDZ)

The first 3000 feet of runway or the first third of the runway, whichever is less, measured from the threshold in the direction of landing.

**TOUCHDOWN ZONE
ELEVATION (TDZE)**

The highest elevation in the touchdown zone.
The projection on the earth's surface of the path of an

TRACK

Aircraft, the direction of which path at any point is usually expressed in degrees from North (true, magnetic or grid).

TRANSITION AREA

Controlled airspace of defined dimensions extending upwards from 700 feet AGL, unless otherwise specified, to the base of overlying airspace.

TRANSPONDER

A receiver/transmitter which will generate a reply signal upon proper interrogation; interrogation and reply being on different frequencies.

VISUAL APPROACH

An approach wherein an aircraft on an IFR flight plan, operating in VFR weather conditions under the control of an air traffic control facility and having an air traffic control authorization, may proceed to the airport of destination in VFR weather conditions.

**VISUAL METEOROLOGICAL
CONDITIONS (VMC)**

Meteorological conditions expressed in terms of visibility, and distance from cloud, equal to or greater than the minima prescribed in the *Air Regulations* for flight in VFR weather.

APPENDIX 2: ABBREVIATIONS

The following abbreviations are commonly used in IFR flying. Other abbreviations may be found in *AIP Canada* GEN and in the *Canada Flight Supplement*.

AAE	Above Aerodrome Elevation	ATC	Air Traffic Control
AAS	Airport Advisory Service	ATF	Aerodrome Traffic Frequency
AASR	Area and Airport Surveillance Radar (Area Control)	ATIS	Automatic Terminal Information Service
abm	abeam	ATZ	Aerodrome Traffic Zone
acft	aircraft	auth	authorized
A/D	Aerodrome	avbl	available
ADCUS	Advise Customs	AWBS	Aviation Weather Briefing Service
ADF	Automatic Direction Finding	AWIS	Aviation Weather Information Service
ADIZ	Air Defence Identification Zone	awy	airway
A/G	Air Ground	BC	Back Course
AGL	Above Ground Level	bcst	broadcast
AIP	Aeronautical Information Publication	bldg	building
alt	altitude	bpoc	Before Proceeding on Course
altn	alternate	brg	bearing
ANO	Air Navigation Order	CAP	The Canada Air Pilot
apch	approach	CAT I	Category I
aprx	approximately	CAT II	Category II
arr	arrival	ceil	ceiling
ARTCC	Air Route Traffic Control Centre	CFB	Canadian Forces Base
ASDA	Accelerate Stop Distance Available	CFS	Canada Flight Supplement
ASL	Above Mean Sea Level	ch	channel
ASR	Airport Surveillance Radar	civ	civil
		clnc	clearance

clsd	closed	EFIS	Electronic Flight Instrument System
CMNPS	Canadian Minimum Navigation Performance Specifications	elev	elevation
comm	communications	emerg	emergency
cont	continuous	Eng	English
crs	course	ETA	Estimated Time of Arrival
ctl	control	ETD	Estimated Time of Departure
CZ	Control Zone	ETE	Estimated Time En route
del	delivery	exc	except
dep	departure	FACF	Final Approach Course Fix
DAH	Designated Airspace Handbook	FAF	Final Approach Fix
DCPC	Direct Controller - Pilot Communications	FAS	Flight Advisory Service
DF	Direction Finding	FIR	Flight Information Region
DH	Decision Height	FL	Flight Level
direc	direct or directional	fld	field
dist	distance	FM	Fan Marker
dly	daily	FMS	Flight Management System
DME	Distance Measuring Equipment	Fr	French
DND	Department of National Defence	freq	frequency
DOT	Department of Transport	FSS	Flight Service Station
DRCO	Dial-up RCO	GASA	Geographic Area Safe Altitude
DT	Daylight Saving Time	GEOREF	Geographical Reference
dur	during	gnd	ground
EAT	Expected Approach Time	GP	glide path
EET	Estimated Elapsed Time	GPI	Ground Point of Interception
EFC	Expected Further Clearance Time	GPS	Global Positioning System
eff	effective	GPWS	Ground Proximity Warning System
		GS	Glide Slope



H24	continuous operation	JBI	James Brake Index
HAA	Height Above Aerodrome	KHz	Kilohertz
HAT	Height Above Touchdown	kt	knots
hdg	heading	lat	latitude
H	High Frequency	LDA	Landing Distance Available
Hg	Inches of mercury	LF	Low Frequency
HAL	High Intensity Approach Lighting	lgt	light or lighting
HIRL	High Intensity Runway Lights	lgtd	lighted
hol(s)	holiday(s)	LOC	Localizer (For non-precision approach procedures predicated on a localizer facility)
HR	hour	long	longitude
HUD	Head Up Display	LR	Lead Radial
IAF	Initial Approach Fix	ltd	limited
ICAO	International Civil Aviation Organization	M or Mag	Magnetic
ident	identification	maint	maintenance
IF	Intermediate Fix	max	maximum
IFR	Instrument Flight Rules	MB	Millibars
ILS	Instrument Landing System	MDA	Minimum Descent Altitude
IMC	Instrument Meteorological Conditions	MEA	Minimum En route Altitude
inbd	inbound	MF	Mandatory Frequency
inop	inoperative	M or mil	military
INS	Inertial Navigation System	min	minimum
inst	instrument	min	minute of time
intl	international	MHz	Megahertz
intrim	interim	MLS	Microwave Landing System
intxn	intersection	MNPS	Minimum Navigation Performance Specifications
IRS	Inertial Reference System	MOCA	Minimum Obstruction Clearance Altitude
ISA	International Standard Atmosphere		

MSA	Minimum Sector Altitude	RA	Radar Altimeter
muni	municipal	RCR	Runway Condition Report
NAT	North Atlantic	rdo	radio
navaid	navigation aid	RIL	Runway Identification Lights
NDB	Non-Directional Beacon	RNAV	Area Navigation
NM	Nautical Miles	RNPC	Required Navigation Performance Capability
No PT	No Procedure Turn (Procedure turn not required from point indicated)	ROC	Required Obstacle Clearance
NOTAM	Notices to Airmen	req	required
ntc	notice	req'd	required
NWS	North Warning System	RVR	Runway Visual Range
OBS	Omni Bearing Setting	rwy	runway
obst	obstruction	sec	second of time
OCL	Obstacle Clearance Limit	SELCAL	Selective Calling System
ocnl	occasional	SID	Standard Instrument Departure
OM	Outer Marker of ILS	sked	schedule
Opr	operator or operates	sr	sunrise
O/R	On Request	ss	sunset
O/T	Other Times	STAR	Standard Terminal Arrival Route
PAL	Peripheral A/G Station	T	True
PAPI	Precision Approach Path Indicator	TA (3000)	Transition Altitude
PAR	Precision Approach Radar	TAS	True Airspeed
pos'n	position	TACAN	Tactical Air Navigation Equipment (UHF Omni Range)
PPR	Prior Permission Required	TC	Transport Canada
pro	procedure	TCA	Terminal Control Area
PT	Procedure Turn	TCA	Transport Canada Aviation
quad	quadrant	TCAS	Traffic Alert and Collision Avoidance System
R	radial		



TCH	Threshold Crossing Height	VORTAC	Combination of VOR and TACAN
TDZ	Touchdown Zone	VOT	VOR Receiver Test Facility
TDZE	Touchdown Zone Elevation	Vso	Stall speed in landing configuration
TDZL	Touchdown Zone Lighting	WP	Way Point
tel	telephone	wx	weather
tkof	Take Off	Z	Coordinated Universal Time
tml	terminal		
TODA	Take-off Distance Available		
TORA	Take-off Run Available		
TWR	control tower		
twy	taxiway		
UFN	Until Further Notice		
UHF	Ultra High Frequency		
UNICOM	Private Advisory Station		
unrel	unreliable		
U/S	unserviceable		
UTC	Coordinated Universal Time		
var	variation		
VASIS	Visual Approach Slope Indicator System		
VDG	VHF Direction Finder		
VFR	Visual Flight Rules		
VHF	Very High Frequency		
vis	visibility		
VMC	Visual Meteorological Conditions		
Vmc	Minimum Control Speed		
VOLMET	Meteorological Information for Aircraft in Flight		
VOR	VHF Omni-directional Range		

NOTE:

Additional abbreviations and an aerodrome/facility directory legend are listed in the GENERAL sections of the Canada Flight Supplement and AIP Canada.

APPENDIX 3: RULES OF THUMB

3.1 GROUND SPEED CHECK

Groundspeed can be determined through the use of the slant range provided by DME; it is then applied to the formula:

$$\frac{\text{DISTANCE FLOWN} \times 60}{\text{ELAPSED TIME IN MINUTES}} = \text{GROUND SPEED}$$

Checks should be performed only:

- a/ while tracking directly to or from a DME site; and
- b/ when aircraft slant range exceeds the aircraft altitude in thousands of feet.

Conduct an elapsed timing of the distance display from a range indicator:

- a/ for at least one minute (longer timings produce more accurate results); and
- b/ starting from any change-over to a whole-number display on the range indicator.

The data derived may be converted to groundspeed by either of the following methods:

- a/ *Flight Computer* - set the elapsed time in minutes (inner minute scale) opposite the distance travelled (outer miles scale) and read groundspeed on the outer scale opposite the black arrowhead speed index; and
- b/ *Mental DR* - conduct the elapsed timing for a convenient fraction of an hour and carry out the appropriate multiplication, eg, groundspeed:
 - = distance travelled in 1 minute x 60
 - = distance travelled in 2 minutes x 30
 - = distance travelled in 3 minutes x 20
 - = distance travelled in 6 minutes x 10

Using a Mach indicator, obtain distance using this formula:

[**Mach = MPM (miles per minute)**]; then multiply by 6 to determine groundspeed. With the Mach indicator, to obtain TAS, multiply Mach x 6 = TAS.

3.2 APPROXIMATE BANK ANGLE FOR RATED TURNS (KNOTS)

The approximate bank angle required to achieve a standard rate turn (3 degrees per second) is equal to $\frac{1}{10}$ of the TAS plus 7. Therefore, if cruising at 200 knots, the formula would be:

$$\text{RATE 1} = \frac{200}{10} + 7 = 27 \text{ DEGREES BANK}$$

$$\text{RATE 1/2} = \frac{200}{20} + 7 = 17 \text{ DEGREES BANK}$$

3.3 RATE OF DESCENT TO FLY A GLIDE PATH

When performing either a PAR or an ILS approach, the pilot must achieve a rate of descent to maintain the glide path. Rather than guess, use the following formula — bearing in mind that it requires groundspeed.

The rate of descent for a 3-degree glide path equals 5 times the groundspeed. A 2 1/2 degree glide path equals the same basic formula minus 100. For example, with a groundspeed of 110 knots:

$$3 \text{ DEGREES GP} = 110 \times 5 = 550 \text{ FPM}$$

$$2\frac{1}{2} \text{ DEGREES GP} = (110 \times 5) - 100 = 450 \text{ FPM}$$

RATE OF DESCENT TABLE / (FEET PER MINUTE)									
G/P	AVERAGE GROUND SPEED / (KNOTS)								
ANGLE	60	70	80	90	100	120	140	160	180
2°	212	248	283	314	353	424	495	565	636
2.5°	264	310	353	397	442	530	617	705	794
3°	318	370	424	476	530	636	740	847	953
3.5°	370	433	494	558	617	740	866	987	1111
4°	423	495	565	636	706	848	990	1130	1270
4.5°	478	557	636	716	794	955	1112	1270	1430

HEIGHT ABOVE TOUCHDOWN IN FEET VS DISTANCE FROM G/P INTERCEPTION POINT									
GP ANGLE	1/4NM	1/2NM	3/4NM	1NM	2NM	3NM	4NM	5NM	
2°	53	106	159	212	425	637	850	1060	
2.5°	67	133	200	266	532	800	1065	1330	
3°	80	159	238	318	635	955	1270	1590	
3.5°	93	186	279	372	745	1120	1490	1860	
4°	106	212	318	425	850	1275	1700	2120	
4.5°	120	239	358	478	955	1435	1915	2390	



3.4 PITCH (ATTITUDE) CHANGES

For high performance aircraft *equipped with a mach indicator*, the basic rule is:

1 degree of pitch change will produce a change of vertical speed equal to 1,000 times the mach number. For example, if cruising along at mach 0.8:

$$1 \text{ DEGREE} \times 0.8 \times 1,000 = 800 \text{ FPM CLIMB OR DESCENT}$$

For aircraft *not equipped with a mach indicator*, the rule is:

1 degree of pitch change will produce a change of vertical speed equal to miles per minute times 100. For example, at 180 knots, which equals 3 miles a minute, this gives:

$$1 \text{ DEGREE} \times 3 \times 100 = 300 \text{ FPM CLIMB OR DESCENT}$$

Another formula which can be used is:

$$\text{TAS} / 0.6 = \text{V/V FOR } 1^\circ \text{ PITCH CHANGE}$$

3.5 TO INTERCEPT AN ARC FROM A RADIAL

Ground speed should really be used here, but TAS can also be used. First decide on the rate of turn to use and proceed:

- a/ start a rate 1/2 turn at a distance equal to 1 per cent of the speed prior to intercepting the arc, or a rate 1 turn at 1/2 per cent of the speed; and
- b/ assume a TAS of 200 knots, flying toward the facility, to fly along the 15-mile arc:

$$\text{RATE } 1/2 = 1\% \text{ OF } 200 = 2; \text{ START TURN AT } 17 \text{ NM}$$

$$\text{RATE } 1 = 0.5\% \text{ OF } 200 = 1; \text{ START TURN AT } 16 \text{ NM}$$

3.6 TO INTERCEPT A RADIAL FROM AN ARC

The *one-in-sixty rule* is the basis of this concept. The number of radials of lead for the turn equals 60 over the DME of the arc, times the appropriate percentage of the TAS. For example, with a 200-knot TAS, flying around the 15-mile arc, we get:

$$\text{RATE } 1/2 \text{ TURN} = 60/15 \times 2 = 8 \text{ RADIALS}$$

$$\text{RATE } 1 \text{ TURN} = 60/15 = 4 \text{ RADIALS}$$

3.7 LEADPOINTS FOR TURNS TO HEADINGS

- 1/2 standard rate use 1/3 of the bank angle;
- standard rate use 1/2 bank angle.

3.8 TIME AND DISTANCE CALCULATION USING NDB

See Article 2.2.5D for an explanation of how to use an NDB to calculate the time and distance from a facility.

3.9 ALTITUDE CORRECTION

- 2 x altitude deviation = v/v (vertical velocity);
- leadpoint for level off = 10% x v/v

3.10 DRIFT CORRECTION

$$300/\text{TAS} = \text{DEGREES FOR EACH 5KTS OF CROSSWIND}$$

3.11 INTERCEPTING NDB TRACKS

Outbound:

tail (of needle) to desired track plus correction;

Inbound:

desired track to the head (of needle) plus correction.

3.12 TURN RADIUS FOR 30° BANK ANGLE

TAS	Turn Radius (NM)
150	.57
180	.82
210	1.11
240	1.45
270	1.84
300	2.27
330	2.74
360	3.27



APPENDIX 4: REFERENCES FOR INSTRUMENT FLYING

The following reference material on instrument flying is mainly limited to *government publications* from Canada or the US, and ICAO publications relating to international standards and procedures. There is a wealth of information on instrument flying from other sources which is not referenced here.

4.1 SYMBOLS AND LEGENDS ON CHARTS

A description and explanation of legends and symbols used on approach plates and charts, as well as other important information on instrument flying, is contained in the *CFS (Canada Flight Supplement)* and *CAP (Canada Air Pilot)*.

In the *CFS*, this information is contained in Section A - General. In the *CAP*, this information is contained in the General Information (GEN) Section at the beginning of the publication.

4.2 GENERAL REFERENCE MATERIAL

Other valuable general information on instrument flying is contained in the COM, MET and RAC sections of the *AIP*.

Additional information and reference material is available in the FAA publication *Instrument Flying Handbook* (AC 61-27C). Other general information on instrument flying is available in TP 975, *Flight Instructor Guide*, in the aviation publication *From the Ground Up*, and in the *Flight Training Manual*, Exercise 24.

4.3 INSTRUMENT CRITERIA

Information on instrument procedural criteria is contained in TP 308, *Criteria For the Development of Instrument Procedures*.

4.4 AIRSPACE INFORMATION

Airspace information is available in TP 1820, the *Designated Airspace Handbook* and in *AIP Canada*.

4.5 METEOROLOGICAL INFORMATION

Meteorological information can be obtained in the *Air Command Weather Manual and Supplement*, as well as the publication *Aware* (English) or *Metavi* (French).

4.6 REQUIREMENTS FOR AN INSTRUMENT RATING

Transport Canada knowledge, experience and skill requirements for the instrument rating are laid out in TP 691, *Study and Reference Guide - Instrument Rating*, TP 9939, *Flight Test Guide - Instrument Rating*, and TP 193, *Personnel Licensing Handbook - Vol. I*.

4.7 SIMULATORS AND GROUND TRAINING DEVICES

Information on ground training devices and simulators approved for IFR training can be obtained from TP 2943, *Personnel Licensing Procedures Manual*, and TP 9685, *Aeroplane and Rotorcraft Simulator Manual*.

4.8 NORTH ATLANTIC OPERATIONS

Guidance for operating in the NAT MNPS (North Atlantic Minimum Navigation Performance Specifications) airspace is contained in the *North Atlantic MNPS Airspace Operations Manual* which is available through ICAO. For pilots wishing to fly the North Atlantic below FL 275, the *North Atlantic International General Aviation Operations Manual* is available through ICAO.

4.9 AEROMEDICAL INFORMATION

Aeromedical and human factors information can be obtained in *The Pilot's Guide to Medical Human Factors* published by Health and Welfare Canada and available through Canada Communications Group.

4.10 CAT II ILS APPROACH REQUIREMENTS

Data on CAT II ILS approach requirements is contained in TP 1490, *Manual of All Weather Operations (Category II)*.

AERONAUTICAL PUBLICATION SERVICES (AARNG)
TRANSPORT CANADA
Place de Ville
Ottawa, Ontario
K1A 0N8
Tel: 1-800-305-2059
613-993-7284
Fax: 613-998-7416
Internet: <http://www.tc.gc.ca/aviation>

Also available on CD-ROM

Catalogue No. T52-54/1997E
ISBN 0-660-17258-5
Revised: November 1997

Canada 

ISBN-0-660-17258-5

